

THERMAL AND NON-THERMAL LASER CUTTING UTILIZING ADVANCED INDUSTRIAL LASERS AND ERL-FELS *

Eisuke J. Minehara,

JAEA, 2-4 Shirakata-shirane, Tokai, Naka, Ibaraki 319-1195, JAPAN.

Abstract

The JAEA and JLAB energy-recovery IR free-electron lasers (ERL-FEL) have successfully demonstrated their capabilities of a sub ps pulse, high efficiency, GW high peak power, kW average power, and wide tunability. Utilizing the high power FEL and ERL technologies, we could realize a more powerful and more efficient FEL than 20kW and 25%, respectively, for nuclear industry, pharmacy, medical, defense, shipbuilding, semiconductor industry, chemical industries, environmental sciences, space-debris cleaning, power beaming and so on very near future. We have performed their thermal and non-thermal cutting experiments using advanced industrial lasers like fiber, and water-jet guided ones and the ERL-FELs, and have characterized them according to their resultant effects.

INTRODUCTION

Two nuclear power plants of the 166MW Tokai power station and 165MW Fugen power stations have been prepared and partially started to decommission in Japan recently. The Tokai power station is the first nuclear power plant for commerce in Japan and decommissioning of the Tokai power station is the first project of the nuclear power plant for commerce in Japan. The Fugen is the advanced thermal reactor prototype using heavy water moderator, light water cooling, and dense piping structure in the core. Feasibility studies of laser cutting are discussed here to compare a few kinds of commercially-available advanced industrial lasers and ERL-FELs with each other.

The currently-available CW lasers like CO₂, YAG, and fiber lasers are widely used to cut, to drill and to peel-off the material sheet, rod, and pipes of stainless steel, zirconium alloy, and others in the power plants, factories and laboratories. Cutting mechanisms of all the lasers listed above to machine the materials are blown off or burn out the melted one by feeding the assisting gases of highly-pressurized inert gases and oxidation gases like N₂, O₂ and others. Therefore, we can easily expect that there are some intrinsic difficulties to cut, to drill and to peel-off the materials wherever and whenever we cannot feed either one of the laser power and pressurized gases to the machining point. We can cut the stainless steel sheet at the speed of 10 meter per minute or even the higher one whenever we can feed enough amounts of the laser power and gas at the cutting point. Double-layered, and multi-layered sheets, and rod and pipe bundles are intrinsically difficult to cut completely using the mechanism discussed

here and all the lasers being commercially-available in the world. Therefore, we have to give up cutting the layered sheets and bundles at once simply using the mechanism and all the lasers. We can only cut the layered sheets layer by layer, and bundles step by step after removal of the cut layer, cut rod, and cut pipe as long as we will use all the commercially-available lasers. The layer by layer and step by step cutting with all the lasers is not so quick enough to decommission the power station facilities. There is no commercially-available sub-ps or a few ps ultra-fast, GW peak power, kW average power free-electron lasers [1] to cut the multi-layered and bundled structures at once. As they have been under development over last 10 years, they will be commercially available next 10 years.

ADVANCED INDUSTRIAL LASERS

The figures 1 and 2 show the fiber laser device and cut sample as one of the typical industrial laser examples.

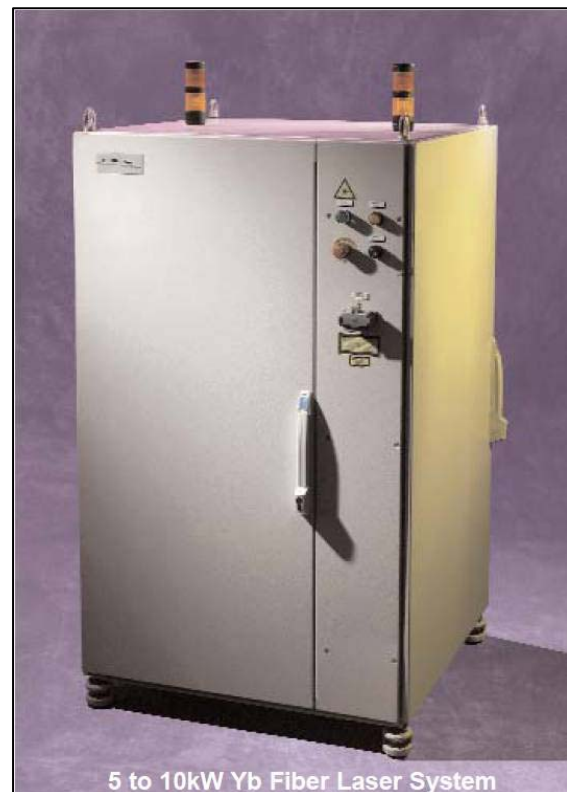

Figure 1: 1 to 50kW CW Ytterbium fiber lasers are manufactured by IPG Photonics. A typical example of the commercially-available advanced industrial CW lasers.

*Work supported by in part by Grants-in-Aid for Scientific Research (A19206103).

minehara.eisuke@jaea.go.jp

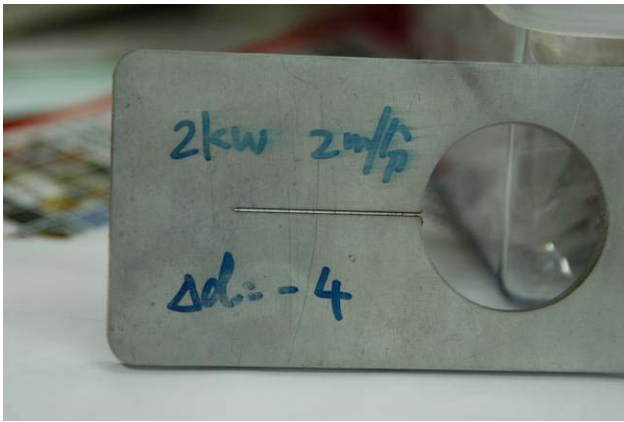

Figure 2: A Stainless-steel plate of 4mm thick and 40mm wide and 80mm long was successfully and quickly cut using 20 bar compressed and focused N₂ gas flow and IPG made 2 kW CW Ytterbium fiber laser. The 2kW fiber laser system usually has a capability of thick metal plate cutting from a few mm up to ten and several mm.

The fiber lasers have been often used to produce the CW power output ranging from several hundred W to 100 kW. In decommissioning the Fugen power station, we can expect about 4000 tons of radioisotope-contaminated waste and 370000 tons of dismantled materials. Especially, we can easily apply the currently and commercially available lasers like fiber lasers to cut and to dismantle the dense piping structure and the thick tank in the Fugen power station.



Figure 3a: A Fugen Zirconium alloy pressurized tube of about 4.3mm thick and 117.8mm inner diameter was successfully and quickly cut with 6m per a minute using 20 bar compressed and focused N₂ gas flow and IPG 5kW fiber laser.

The pressurized tube and Carandoria tube of Zirconium alloy were originally tried to cut at the same instant in the Fugen station. As it is very difficult for currently and commercially available industrial lasers to cut at the same instance, here we tried to cut them one by one by the fiber lasers shown in Figs.3a and 3b. Because the speed of the laser cutting is very fast and reliable in 5-6 m per minute

or even faster, we can directly cut them into the small pieces from the inside to outside using a small and specially -designed laser nozzle one by one.

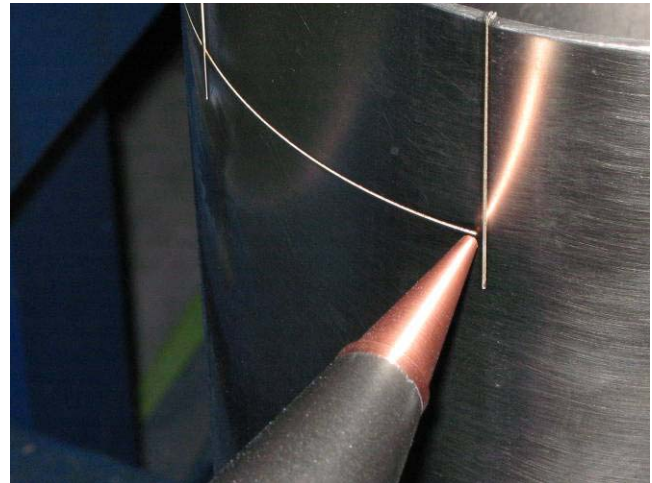

Figure 3b: The Zirconium alloy tube was cut with very high speed of 6m per a minute, and cut-width was as narrow as 0.25mm more or less. Surface condition of the cutting edges is very beautiful and very smooth and slightly narrower than the Stainless steel cases.

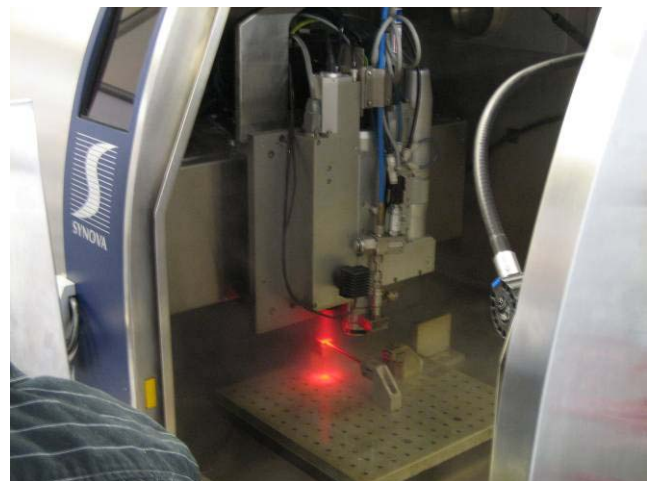

Figure 4: Water jet-guided laser named LMJ(Laser Micro-Jet) driven by 100-200W pulsed YAG laser manufactured by Synova S.A., Switzerland is another typical example of the new, commercially-available, and advanced industrial lasers.

A so-called water jet-guided laser named Laser Micro-Jet(LMJ) shown in Fig.4 is the newest laser - manufacturing tool and applicable to decommissioning of nuclear power plants. The LMJ was recently-invented by the researchers in the early nineties at the Federal Institute of Technology in Lausanne, Switzerland. We already have tried to cut, to drill and to peel-off non-radioactive metal samples. We hope to increase the available laser power in LMJ system from 100W to one kW, and we can easily estimate that the needed duty factor is not so large to be several % more or less.

ERL-FELS

Figure 5 shows the JAEA free-electron laser that we can convert them from quasi-CW machine to full CW or higher duty ones to cut the multi-layered and bundled materials at once. After the conversion, we can sharply cut the very thick tank wall with a very small gap width, drill and peel-off without producing a large amount of radioisotope (RI)-contaminated dusts during the decommissioning operation.

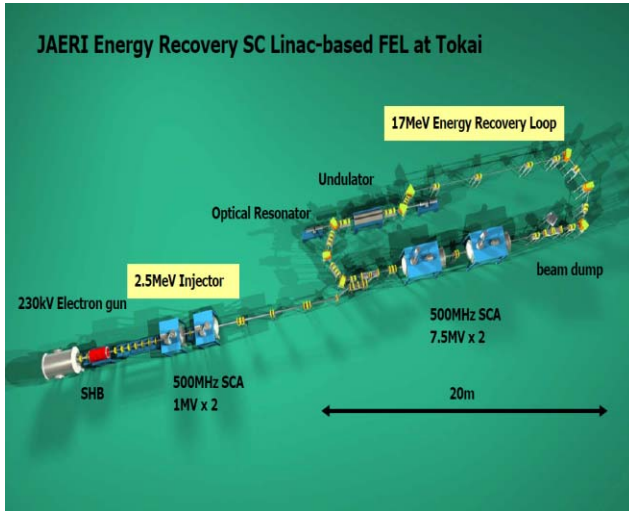

Figure 5: The JAEA energy recovery super-conducting linac-based free-electron laser(ERL-FEL) at Tokai.

Very good cutting performances of ERL-FELs are expected for Stainless-steel and Zirconium alloys because of millions times larger peak power, the same kW high average one, and very good laser divergence.

Three industrial FEL models having the reflextron[2] or similar geometry are illustrated in Fig. 6. Three of them are infrared FELs, and the fourth ultraviolet or visible FEL. As shown in Fig.6, the far-infrared FEL (FIR FEL) ranging from 200 to 50micron wavelengths uses the 500MHz UHF band cavity of 5-10MeV electron energy with the reflextron energy recovery geometry.

A mid-infrared FEL (MIR FEL) ranging from 50 to 8 micron wavelengths will use the 500MHz UHF band cavity of 12-24MeV electron energy with the reflextron geometry. Possible and typical applications are expected to be large-scaled photochemical processing, medical, pharmacy, rare-material separation, radio isotope separation in nuclear decommissioning and so on. A near infrared FEL (NIR FEL) ranging from 12 to 2 micron uses the same 500MHz cavity of 24-48MeV electron beam energy with the reflextron.

As shown in Fig.7, 1.3micron high peak power and high average power JLAB FEL light could instantly cut the 316L stainless-steel bar sample like boiling water reactor components and stainless-steel thick bar without high pressurized blow-off gas. All conventional laser cutters must need a focused and very high pressurized gas flow to blow off narrow part of the laser-heated and melted metal material.

FEL applications

High Power FELs 0.5GHzUHF
12MeV(FIR)/ 24MeV(MIR)/48MeV(NIR)

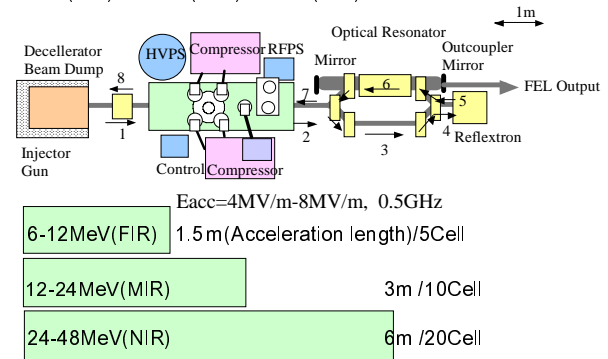

Figure 6: Three industrial FEL models for lasing in the FIR, MIR, and NIR wavelength regions with the reflextron geometry. All of them use the 500MHz UHF band cavities of 5, 10 and 20 cells, respectively.

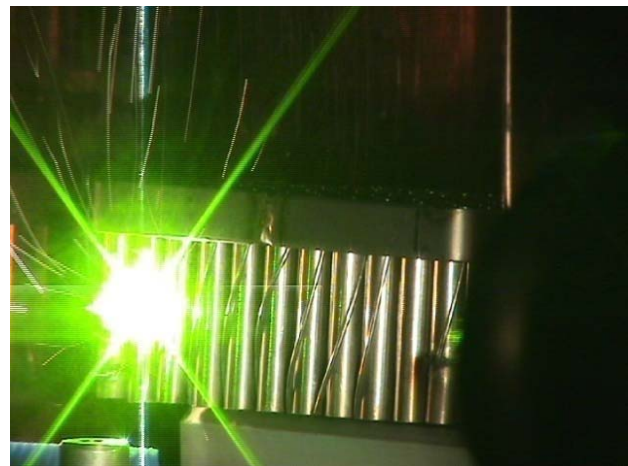

Figure 7: High peak power and high average power JLAB FEL light could instantly cut the 316L stainless-steel bar sample like boiling water reactor components and stainless-steel thick bar without high pressurized blow-off gas.

A 10 or 20kW industrial FEL which can lase at around a fiber-transmittable wavelength of 1.3 micron and at around water transmittable wavelength centered around 0.5 micron will be very useful to transmit their power to a pin-pointed position in a distant area from the FEL. The FEL will be widely used in the many factories like a shipyard, automobile factory, civil engineering, nuclear power plant and so on.

A few FEL application examples will cover the application of non-thermal peeling, cutting, and drilling to decommission the nuclear power plants, and to prevent stress-corrosion cracking in the nuclear decommissioning industry. As a very thin cutting width has been thought to realize a so-called RI contamination free decommissioning, we plan to use a water-jet guiding of FEL light for non-thermal peeling, cutting, and drilling in decommissioning the nuclear power plants. And we also

have demonstrated to prevent cold worked stress-corrosion cracking of the vital components like pressure vessel shroud and recirculation pump piping in the nuclear power plant. The cold worked stress-corrosion cracking sample like BWR shroud is shown in Fig. 8.

A preliminary characterization of the 316L stainless-steel samples shows that the KW CW fiber laser cutting resulted molten zone, high residual tensile stressed area, and high Vickers number hardened layer in the surface, on the other hands, the water jet-guided and JLAB ERL-FEL lasers no molten one, almost no residual tensile stressed one, and the low Vickers number one as the same with the material deep inside.

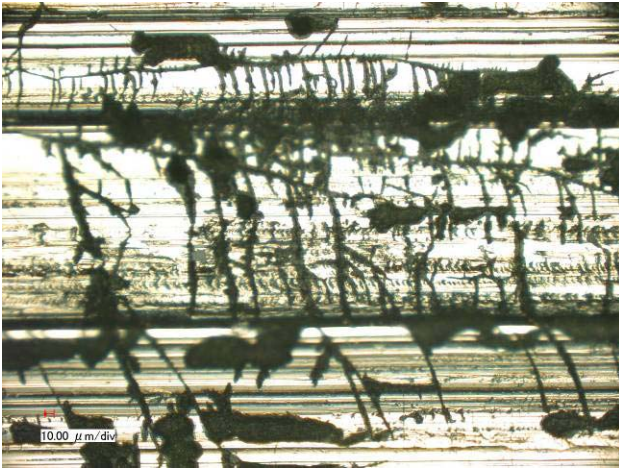

Figure 8: A large number of typical cold worked stress-corrosion cracking(CWSCC) are found in the 316L stainless-steel sample which have often been used in the boiling light water reactor (BWR) shroud and other reactor internal components after the JIS(Japan Industry Standard) defined $MgCl_2$ SCC test of 20 hours.

CONCLUSIONS

The FELs driven by the superconducting RF linac have intrinsically very high average power capability because the linac driver is highly efficient and powerful.

Relatively low efficiency converted from the electron beam to FEL power can be overcome, and increased to recover the remained beam power after the lasing by the ERL. The ERL technology can be usable to make the FEL efficient drastically, and to realize the industrial FELs for many major industry fields including the nuclear power ones soon. The reflextron like geometry can be applied to make the industrial FELs compact, powerful, and efficient because an absolute value of the velocity difference is very small between the acceleration and deceleration along the accelerator cavity at the same position, and we can recover very efficiently the beam power at a few MeV or less electron energy.

We can also add that the preliminary characterization of the 316L stainless-steel samples using ERL-FELs and water jet-guided laser show very clear and promising results for their non-thermal machining capabilities.

ACKNOWLEDGMENTS

The author gratefully express his thanks to Drs. G. Neil, M. Shin, S. Benson, G. Williams, J. Kevin, J. Gubeli and many other colleagues in JLAB FEL facility and all members of JAEA ERL-FEL one for their valuable and kind suggestions and helps on the FEL machining trials, and Profs. H. Horike and T. Fukuda of Osaka University for his continuous encouragement. This work has been supported in part by Grants-in-Aid for Scientific Research (A19206103).

REFERENCES

- [1] Minehara, E.J., et al., "Development and operation of the JAERI superconducting energy recovery linacs", Nucl. Instr. and Meth. in Physics Research Section A, Vol. 557, Issue 1, 1 Feb. 2006, pp 16-22.
- [2] E. A. Heighway, "Magnetic Beam Deflection System". Canadian Patent 993124, issued 1976.