

ECRIS 2016

The 22nd International Workshop on ECR Ion Sources

Status of the PHOENIX V3 ion source R&D



T. Thuillier¹, J. Angot¹, L. Bonny¹, J.-L. Flambard², J. Jacob¹, T. Kalvas⁴, A. Leduc¹,
L. Maunoury², T. Lamy¹, C. Peaucelle³ and P. Sole¹

¹LPSC, Université Grenoble Alpes, CNRS/IN2P3, 53 rue des martyrs 38026 Grenoble cedex, France

²GANIL, CNRS/IN2P3, Bvd Henri Becquerel, BP 55027, 14076 Caen cedex 5

³IPNL, Université de Lyon, Université Claude Bernard Lyon 1, CNRS/IN2P3, UMR5822, IPNL, F-69622 Lyon, France

⁴JYFL, University of Jyväskylä, Finland

SPIRAL2

- Linac, S3, NFS approved (2008)
- DESIR approved (2010)
- RIB production cave postponed (2013)
 - S3 target → DESIR & SPIRAL1 → DESIR

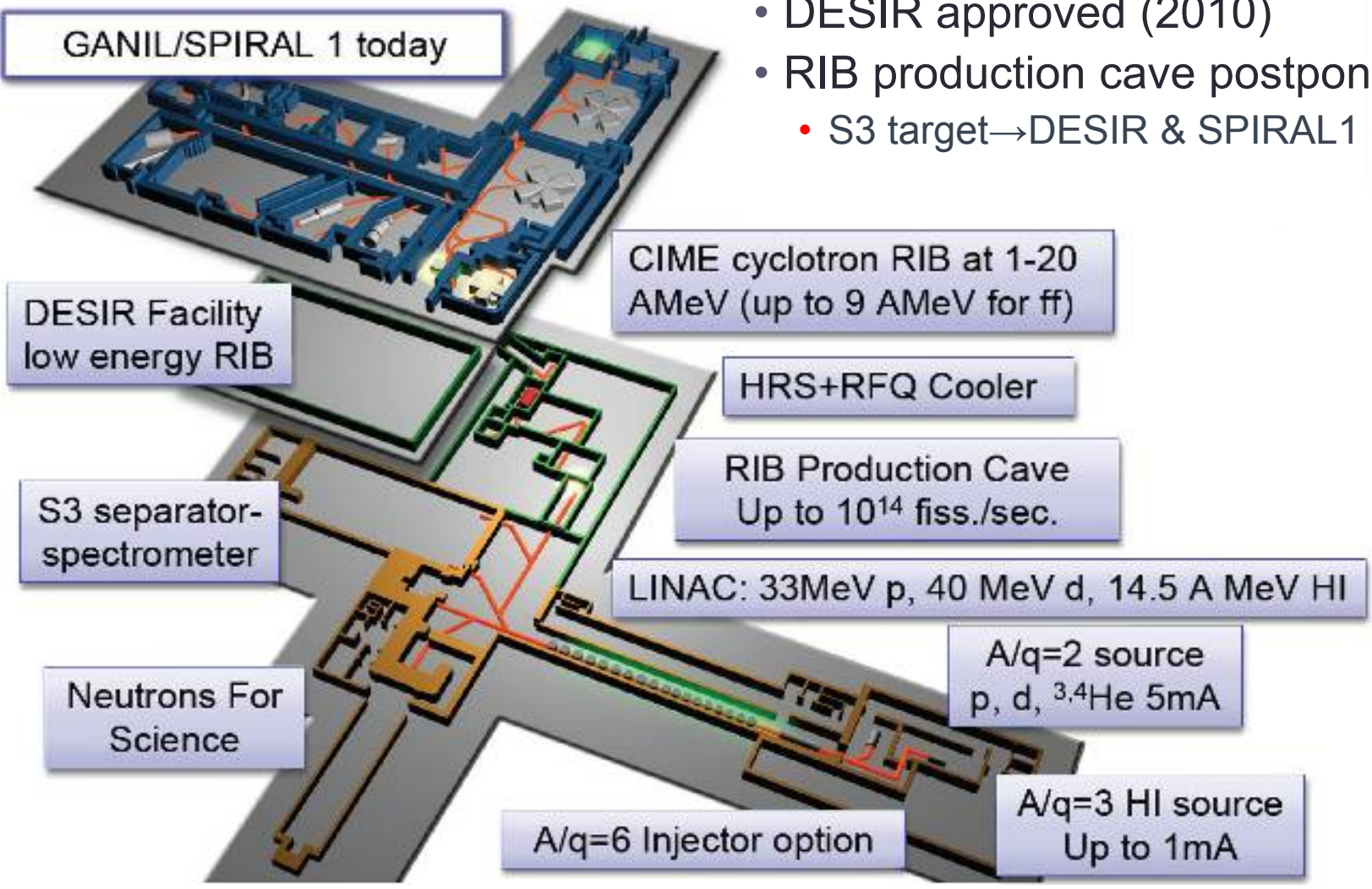

SPIRAL2 ECRIS Strategy with limited funding

- $M/Q=3$ for $M<50$
 - Starter ion source : PHOENIX V2
 - Upgrade granted by the EU CRISP contract : PHOENIX V3
- $M/Q=6-7$ for M up to uranium: prospect
 - New injector required + 2 extra linac cavities
 - New superconducting ion source required
 - collaboration foreseen : GANIL, LPSC, CEA IRFU, IPNL
 - No funding so far
 - The project will start once the DESIR hall will be granted (low energy RIB)

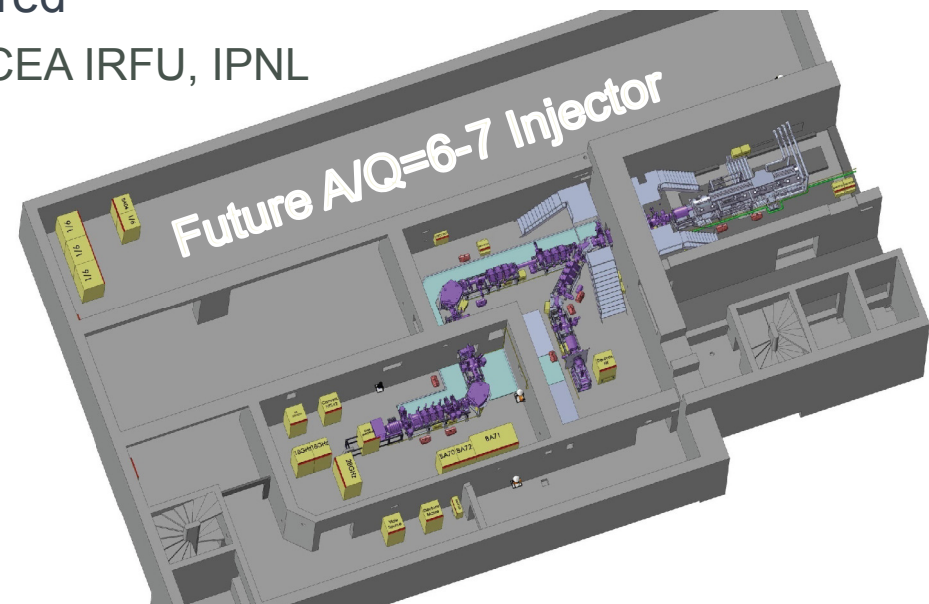

Recent Spiral2 heavy ion source activity



- At GANIL :

- PHOENIX V2 is used to produce high intensity $^4\text{He}^{2+}$ beams to commission the RFQ
- The source is now fully operational at 60 kV
 - It required many ground improvements to make it happen!
- A new 4 mm thick quartz DC breaker was designed as the 2 mm version broke down
- The new breaker has passed long term operation @ 60 kV and high RF power

- At LPSC :

- Assembly of the PHOENIX V3 source
- Full refurbishment of the local LEBT hosting the source



A supply complaining about HV breakdowns

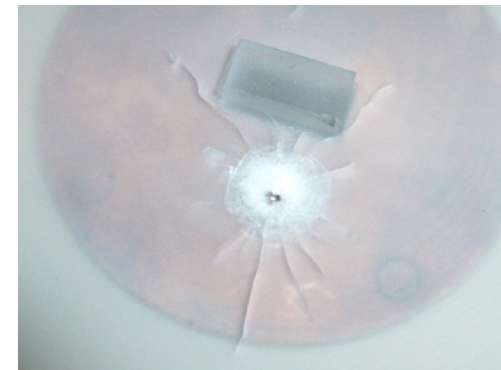

Fused 2 mm DC breaker

Motivation for the PHOENIX V3 upgrade

- CRISP EU collaboration : 200 k€ funding available
 - Funding sufficient to design an upgrade of PHOENIX V2, keeping the ion source hardware/supplies unchanged
 - Solenoid power supplies, RF, beam extraction, mechanical frames...
- Upgrade Goal : improve $M/Q=3$ beam intensities
 - Enhance the production rate of high charge states
 - Reduce the residual pressure in the plasma chamber
- How
 - Increase the plasma volume by increasing the plasma chamber radius
 - Keep the radial confinement intensity at wall \sim constant
 - Keep the existing axial confinement system
 - Add a turbo pump at the injection

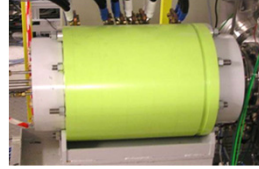

PHOENIX upgrade : V2→V3

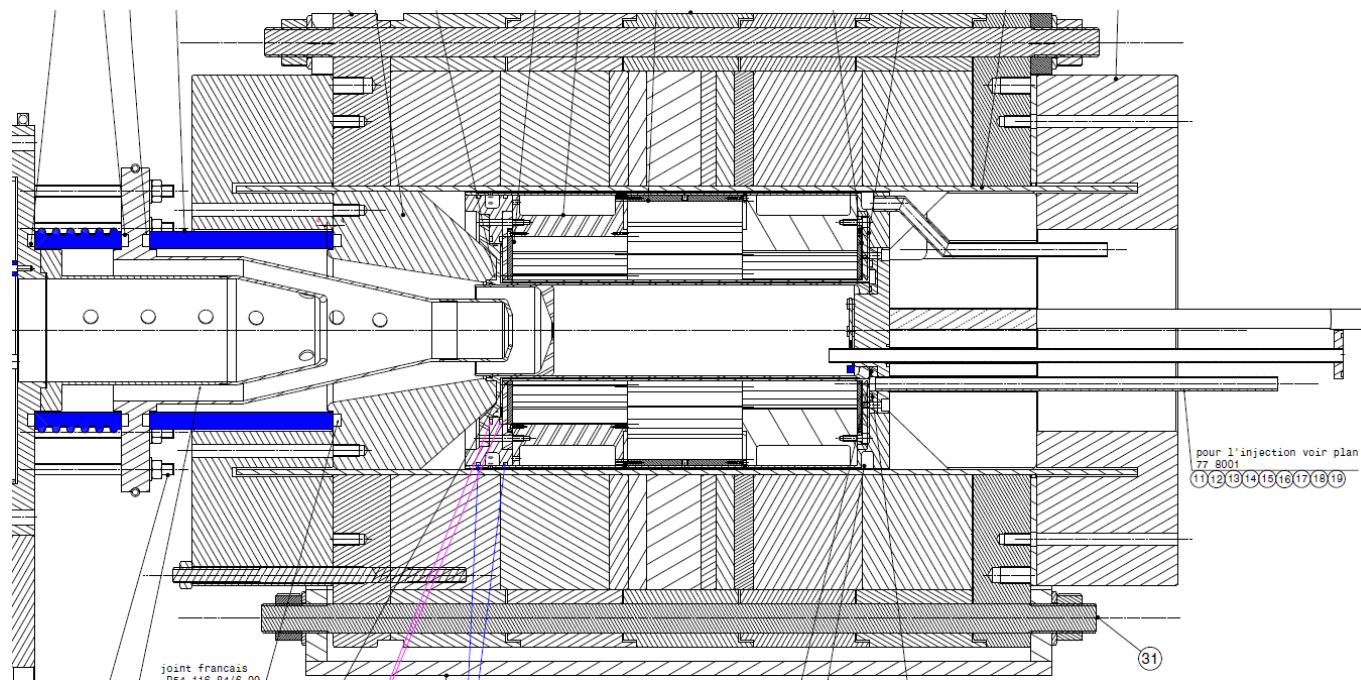

PHOENIX upgrade : V2→V3

Axial magnetic structure

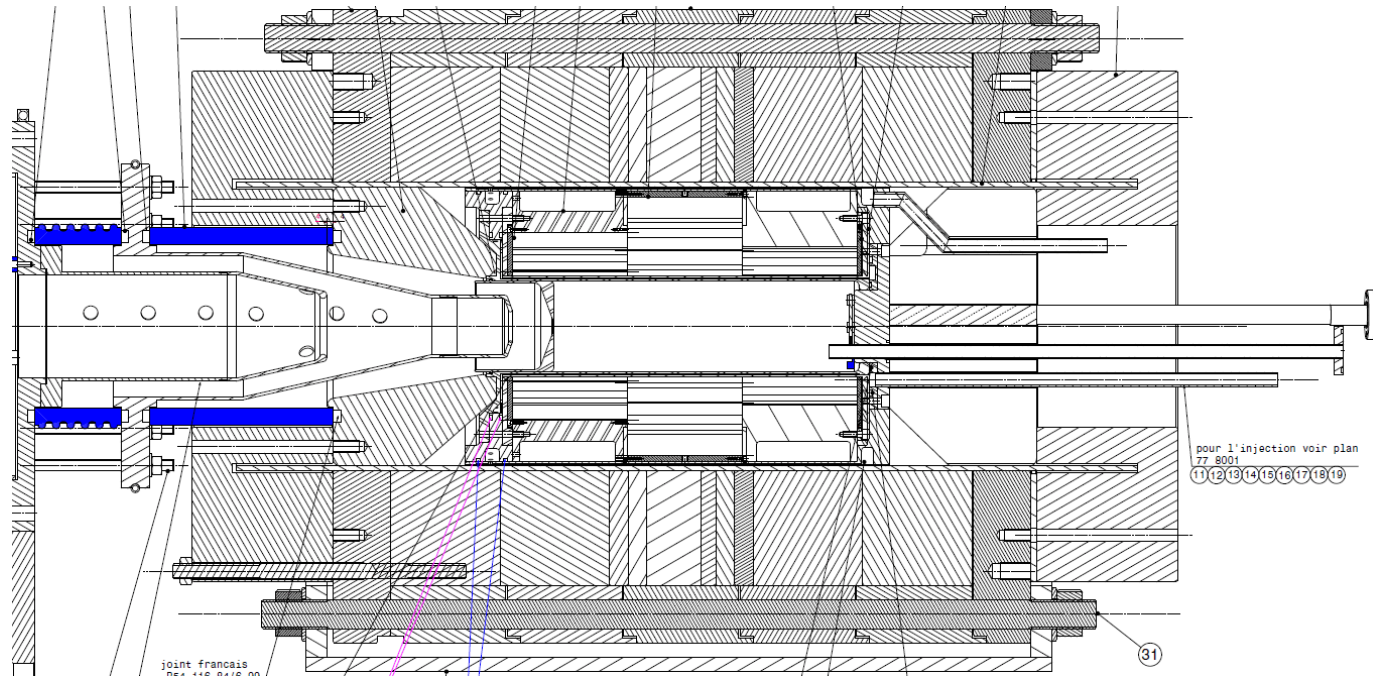

PHOENIX upgrade : V2→V3

Axial magnetic structure

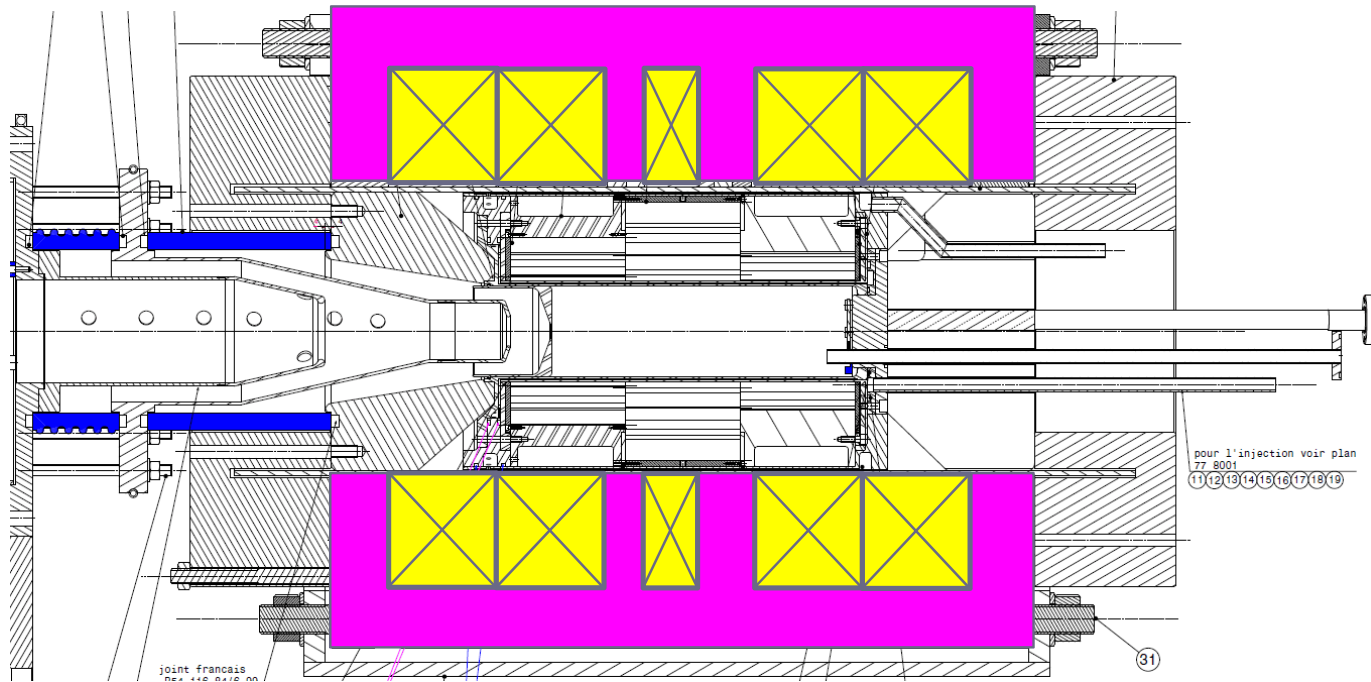

PHOENIX upgrade : V2→V3

Axial magnetic structure

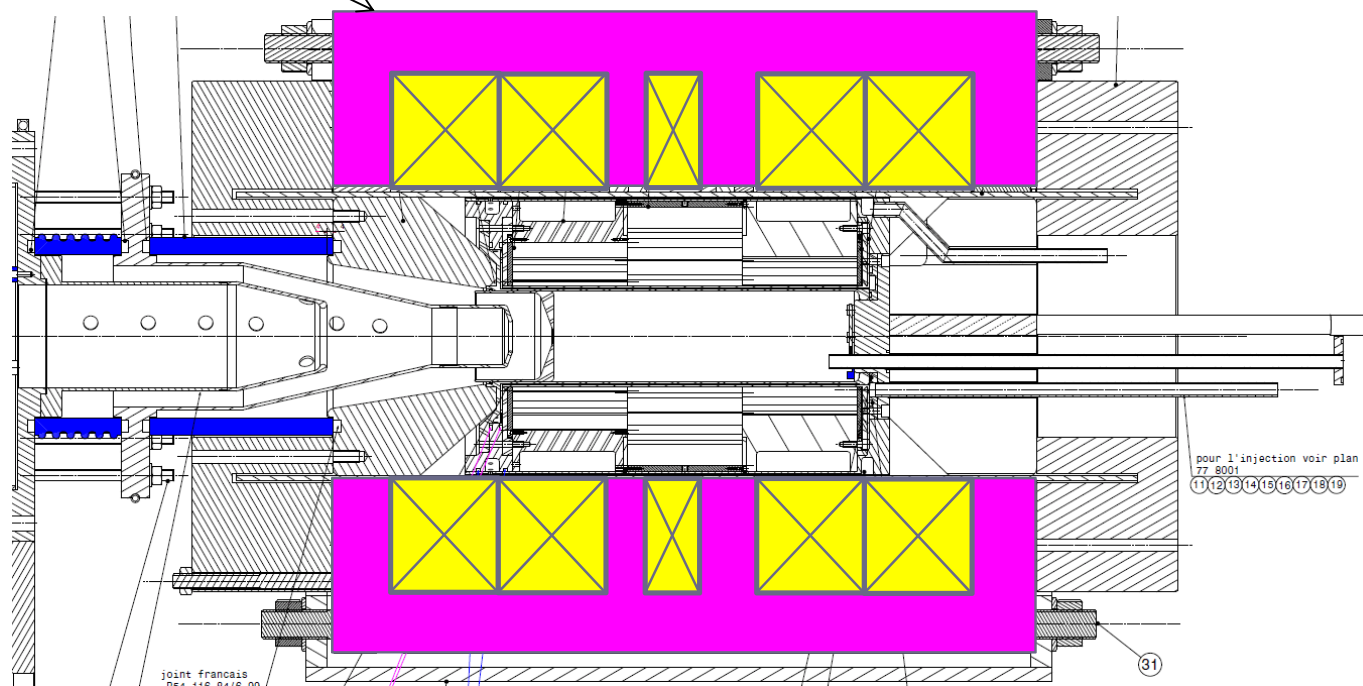

PHOENIX upgrade : V2→V3

Axial magnetic structure

Main HV insulator

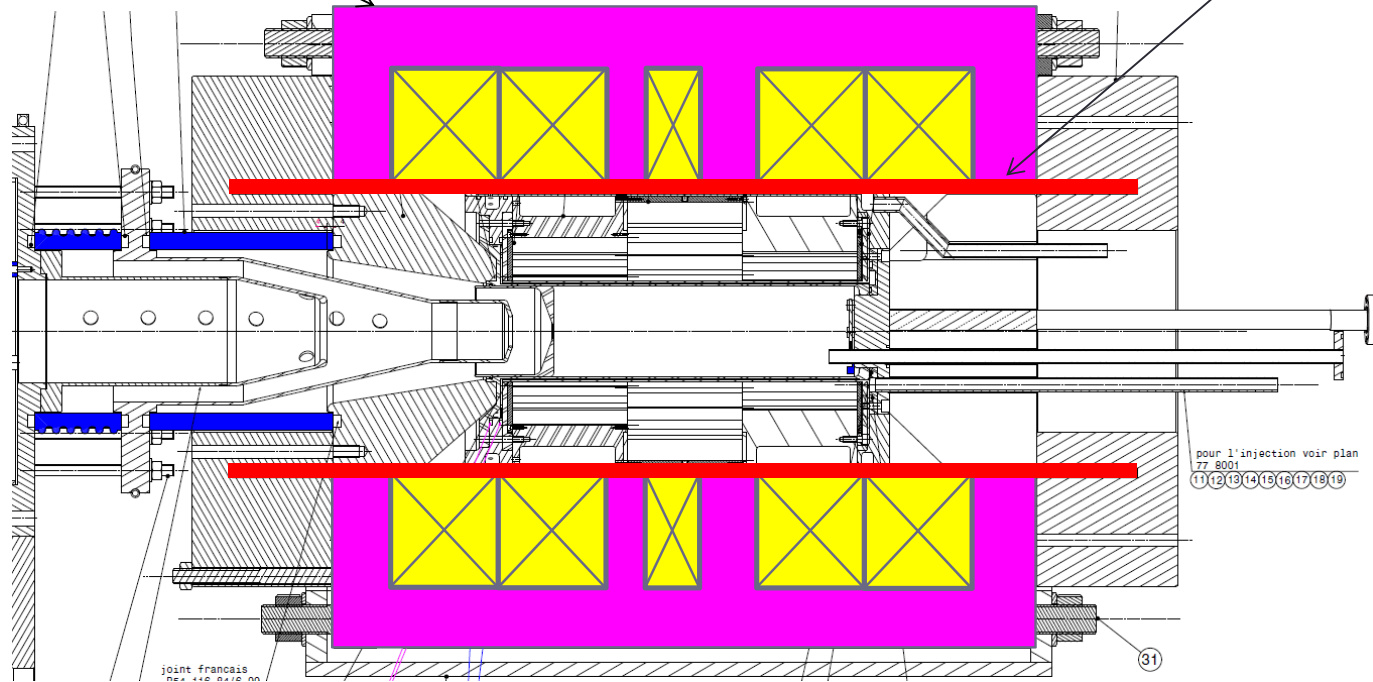

PHOENIX upgrade : V2→V3

Axial magnetic structure

Main HV insulator

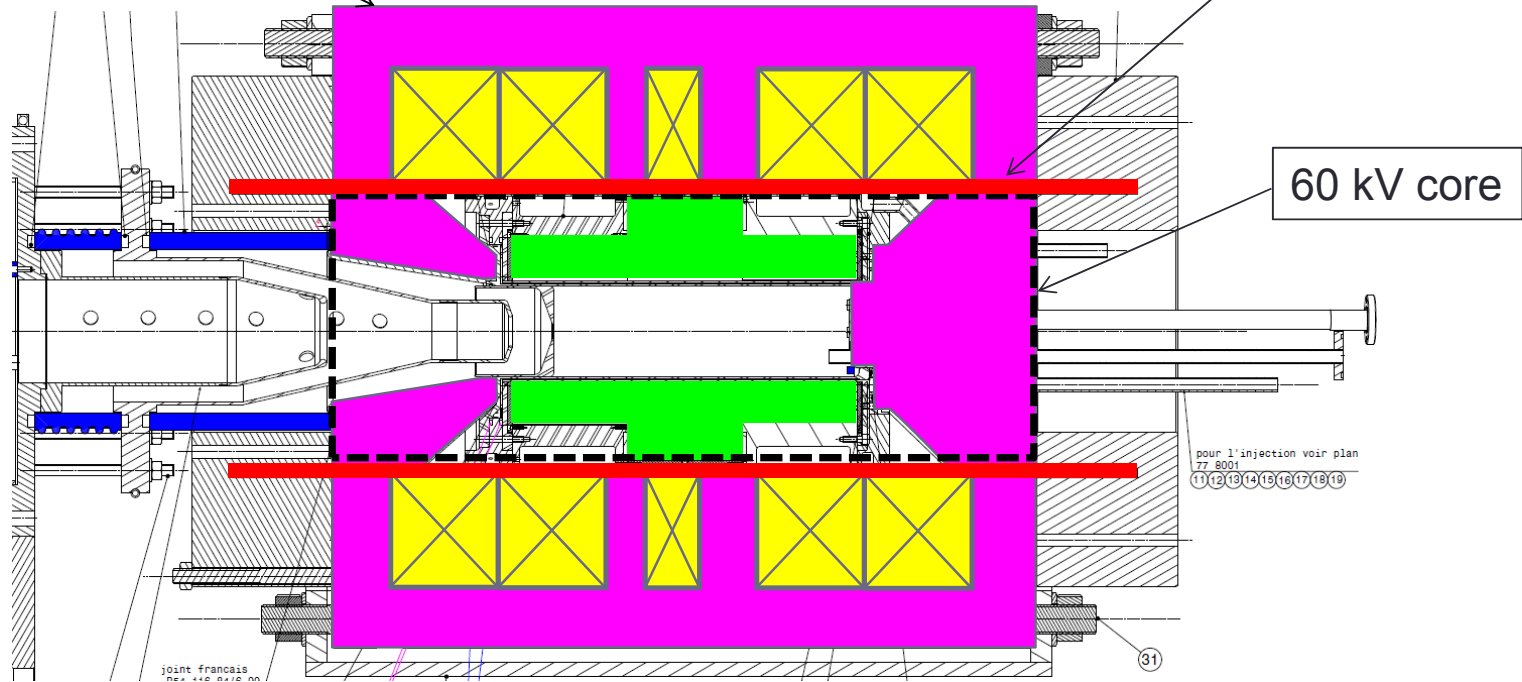

PHOENIX upgrade : V2→V3

Axial magnetic structure

Main HV insulator

60 kV core

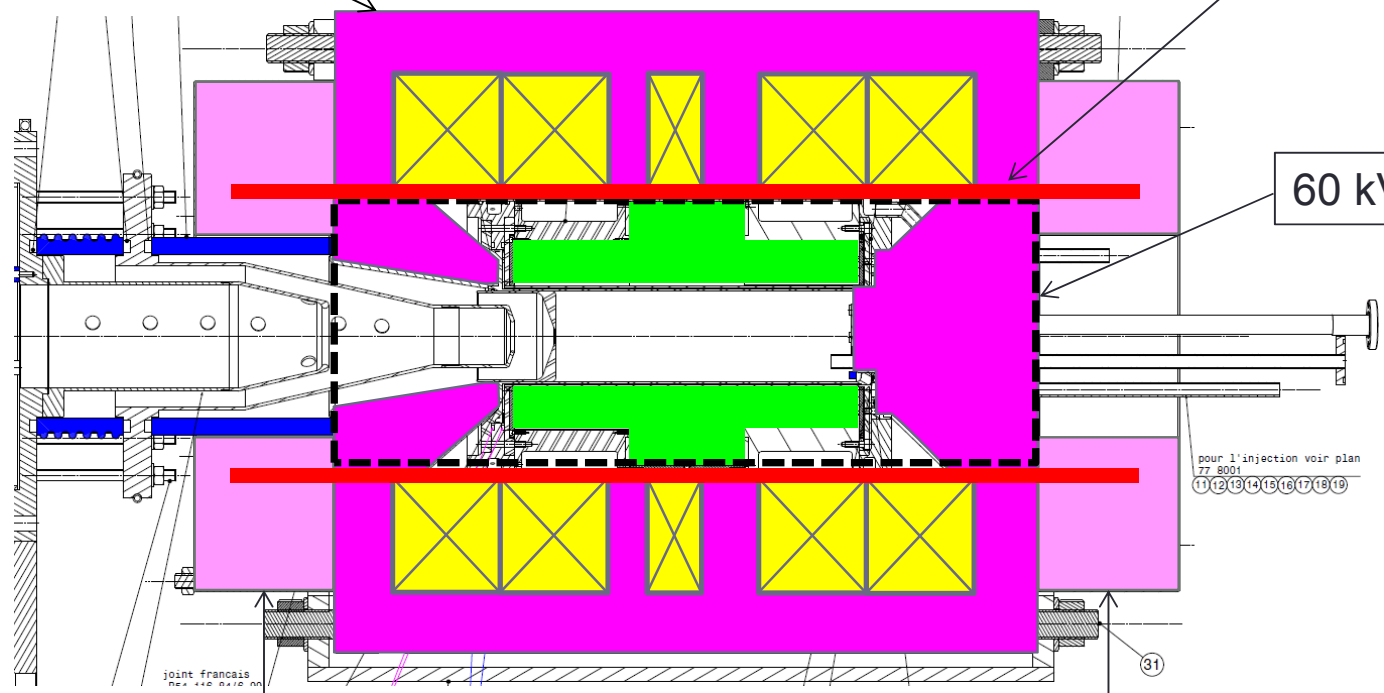

Two insulated flanges to clamp the core

PHOENIX upgrade : V2→V3

Axial magnetic structure

Main HV insulator

60 kV core

2 gap extraction System
60/30/0 kV

Two insulated flanges to clamp the core

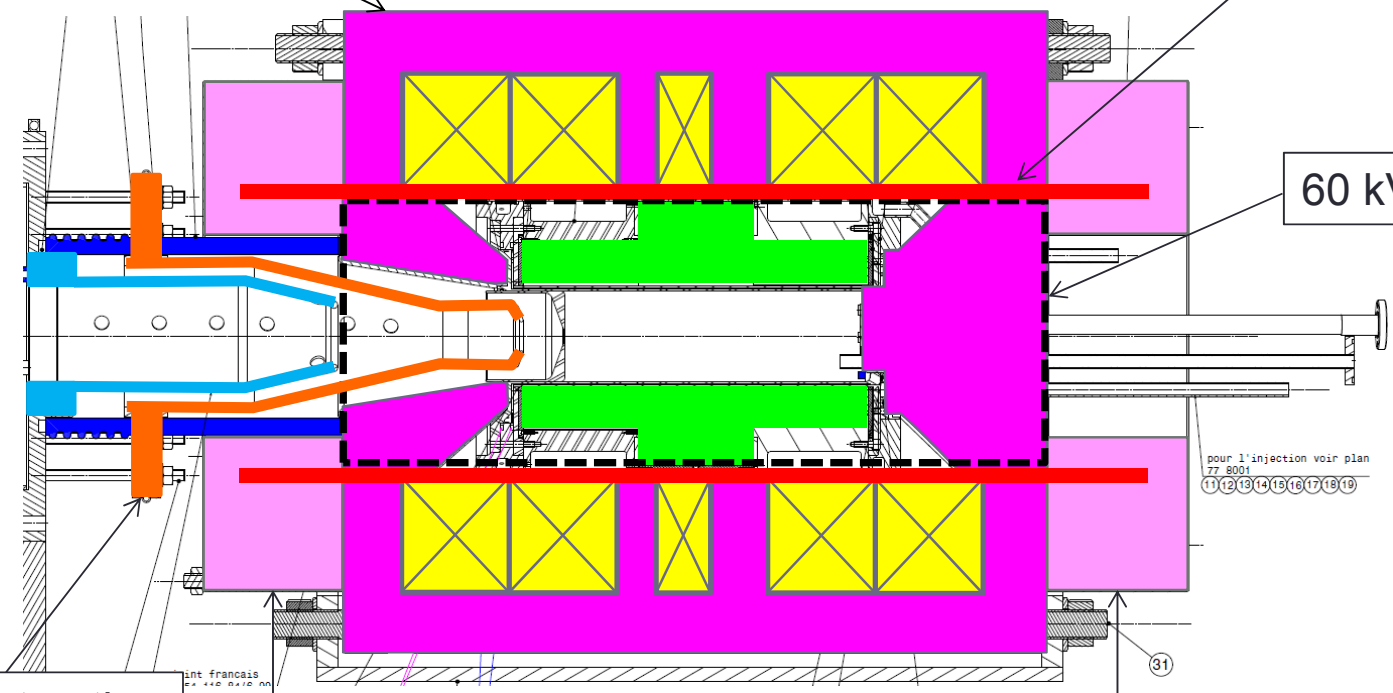

pour l'injection voir plan
177 8001
11 12 13 14 15 16 17 18 19

ant français
Ex 410 010 00

31

PHOENIX upgrade : V2→V3

Axial magnetic structure

Main HV insulator

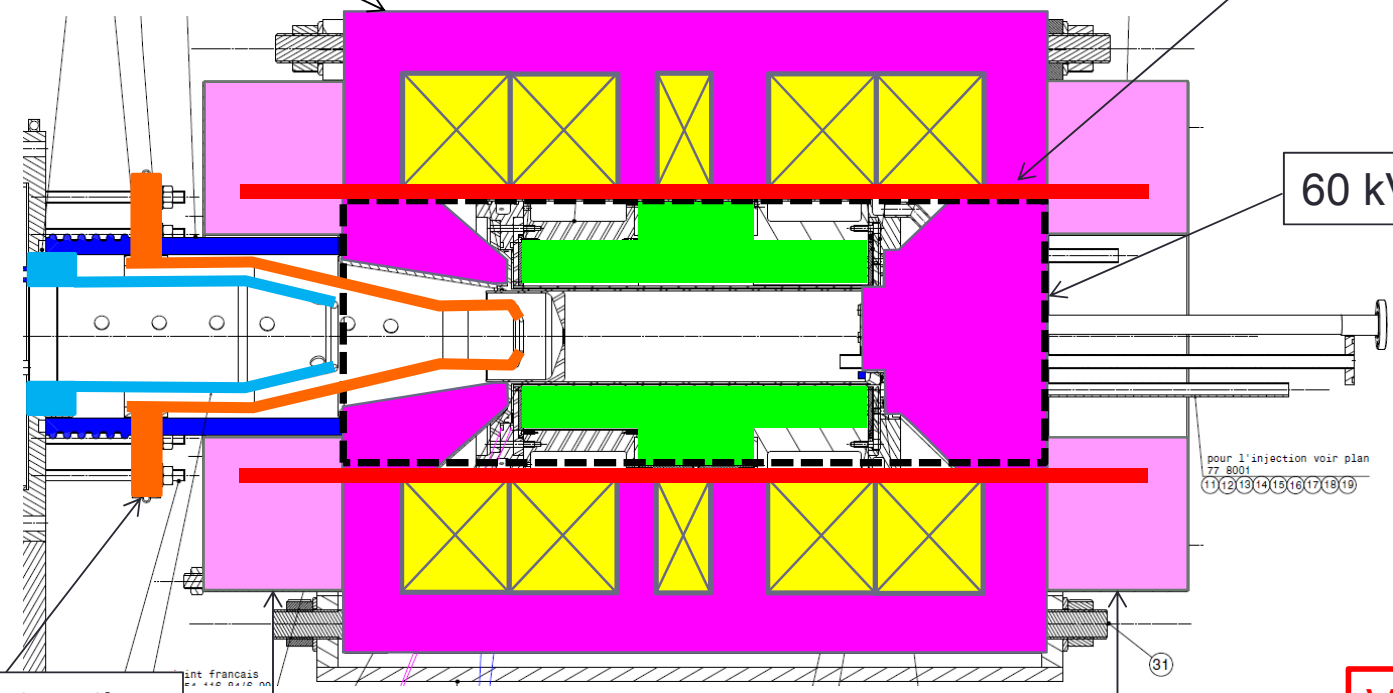

60 kV core

2 gap extraction System
60/30/0 kV

Two insulated flanges to clamp the core

V0,6 litre
Ø62mm
L200 mm

PHOENIX upgrade : V2→V3

Axial magnetic structure

Main HV insulator

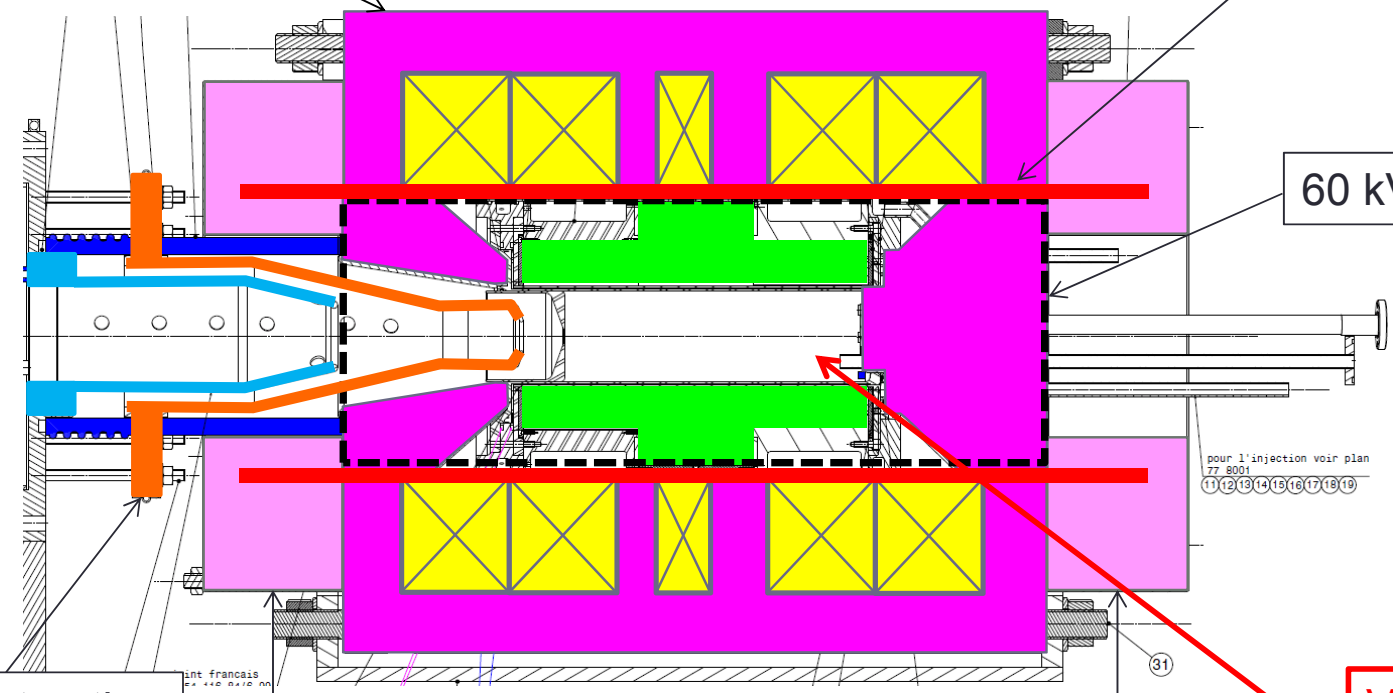

60 kV core

2 gap extraction System
60/30/0 kV

Two insulated flanges to clamp the core

V0,6 litre
Ø62mm
L200 mm

PHOENIX upgrade : V2→V3

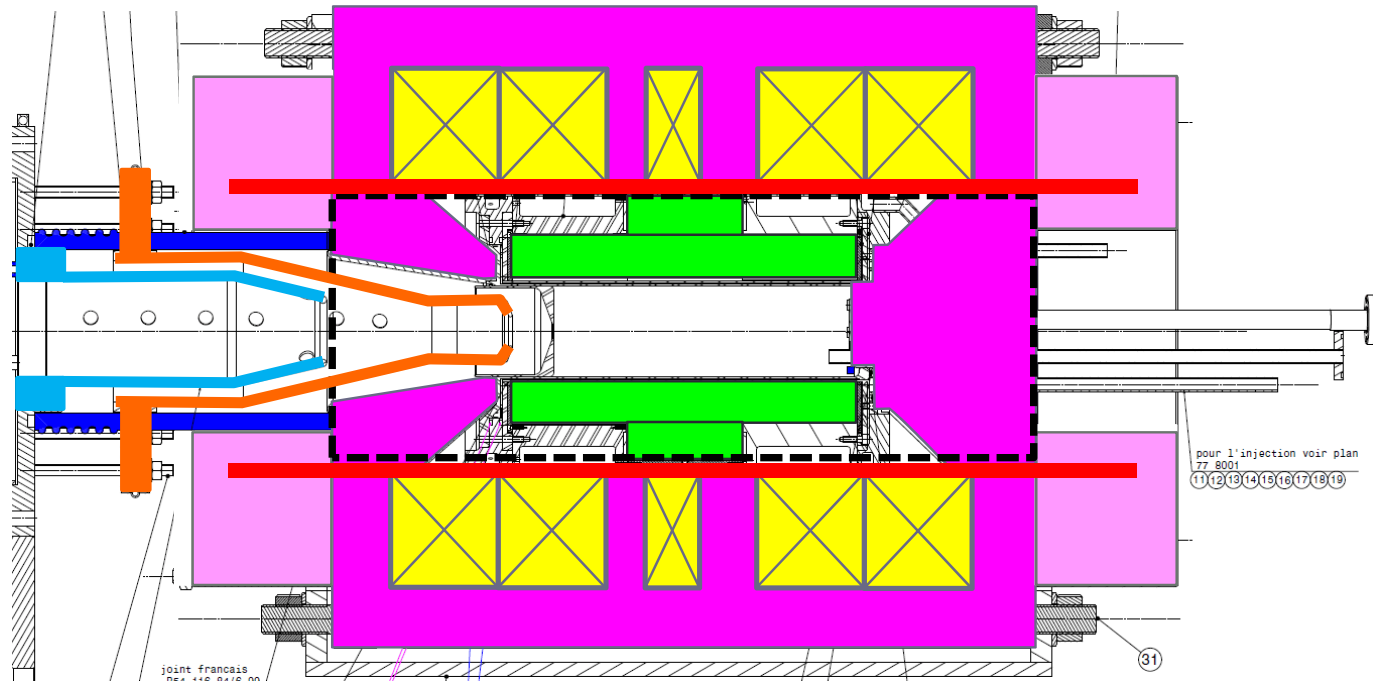

PHOENIX upgrade : V2→V3

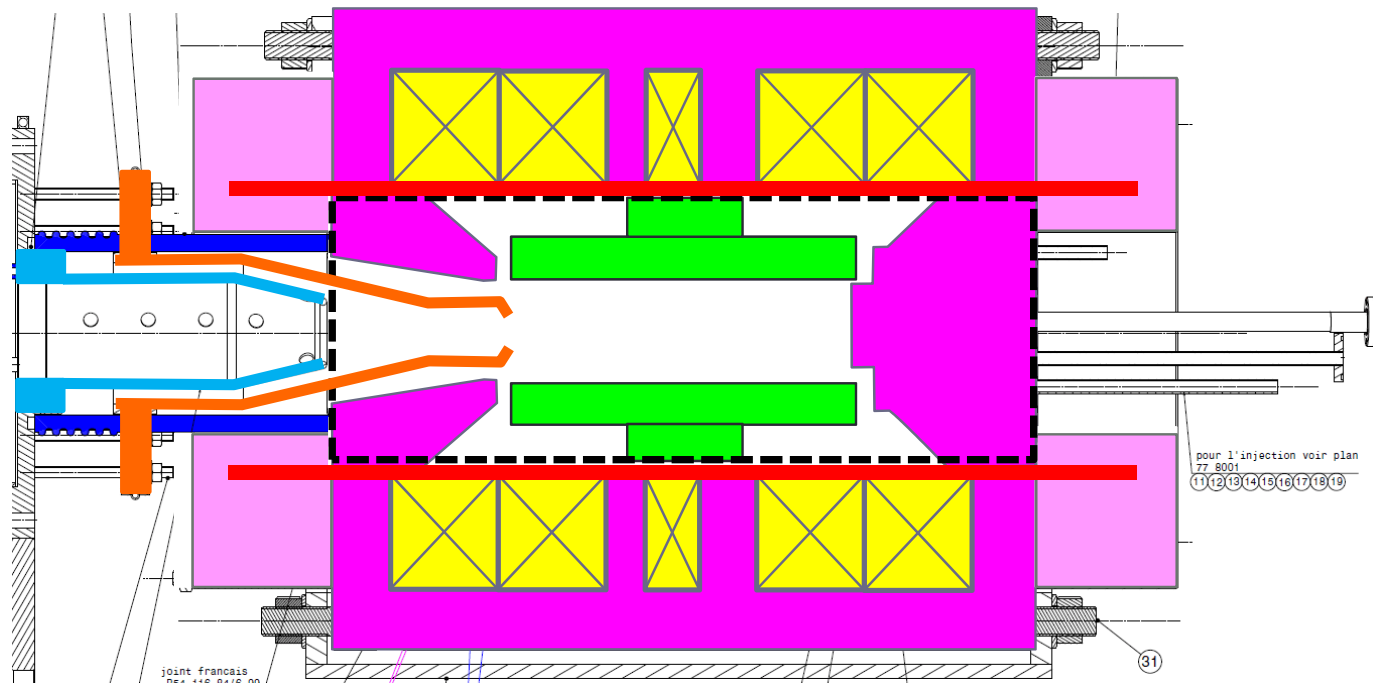

PHOENIX upgrade : V2→V3

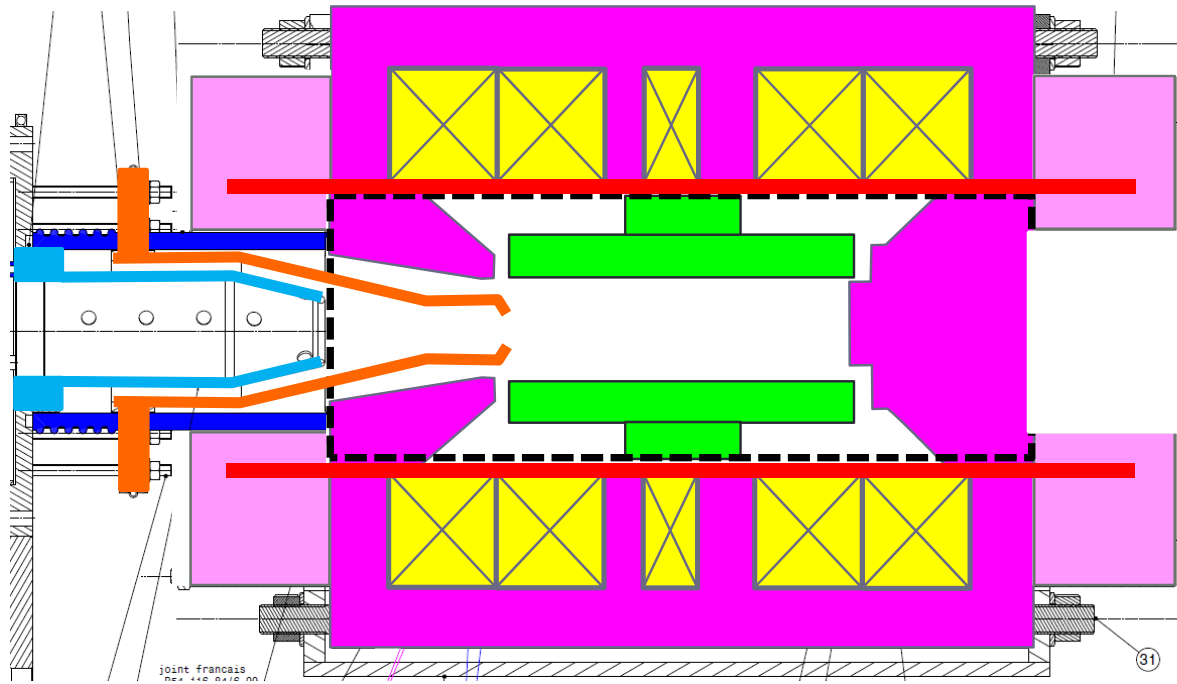

PHOENIX upgrade : V2→V3

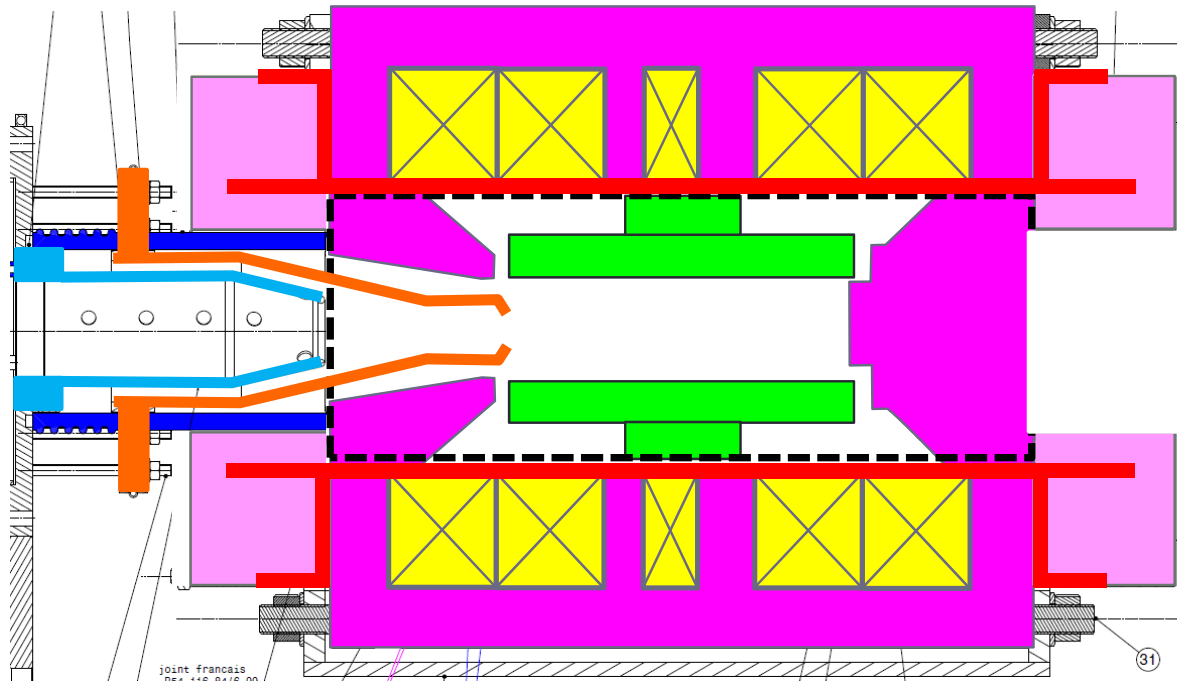

PHOENIX upgrade : V2→V3

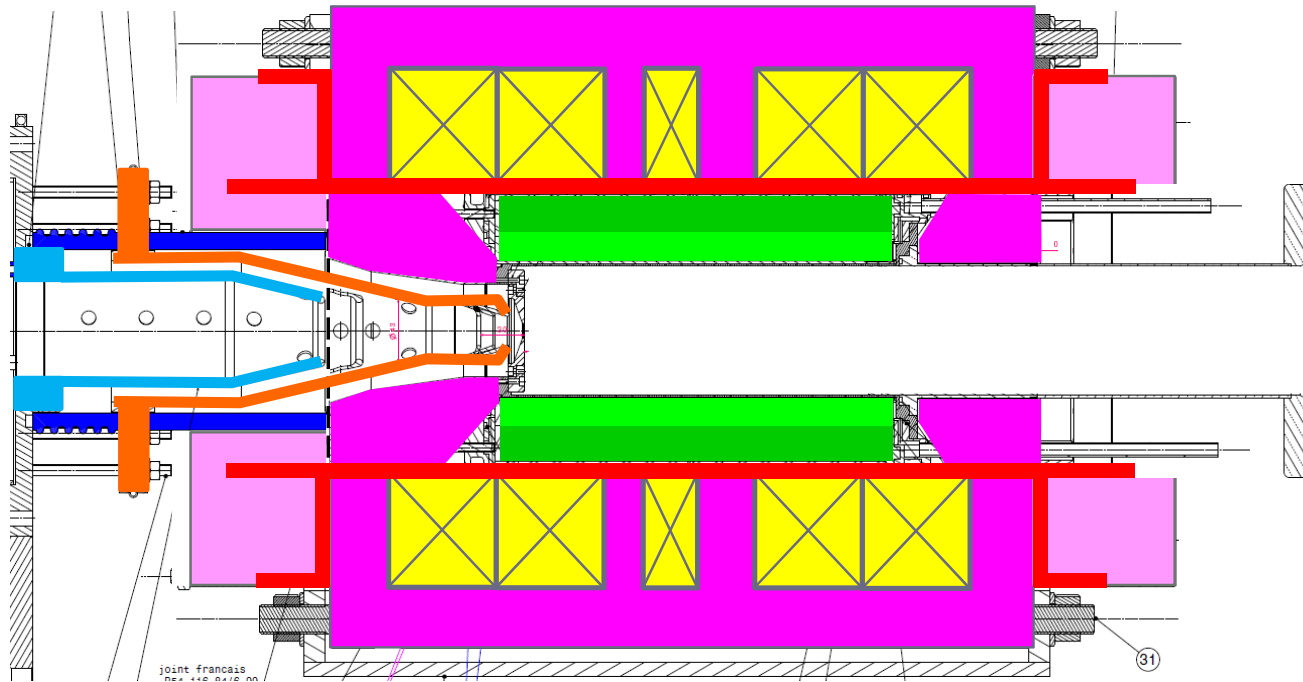

PHOENIX upgrade : V2→V3

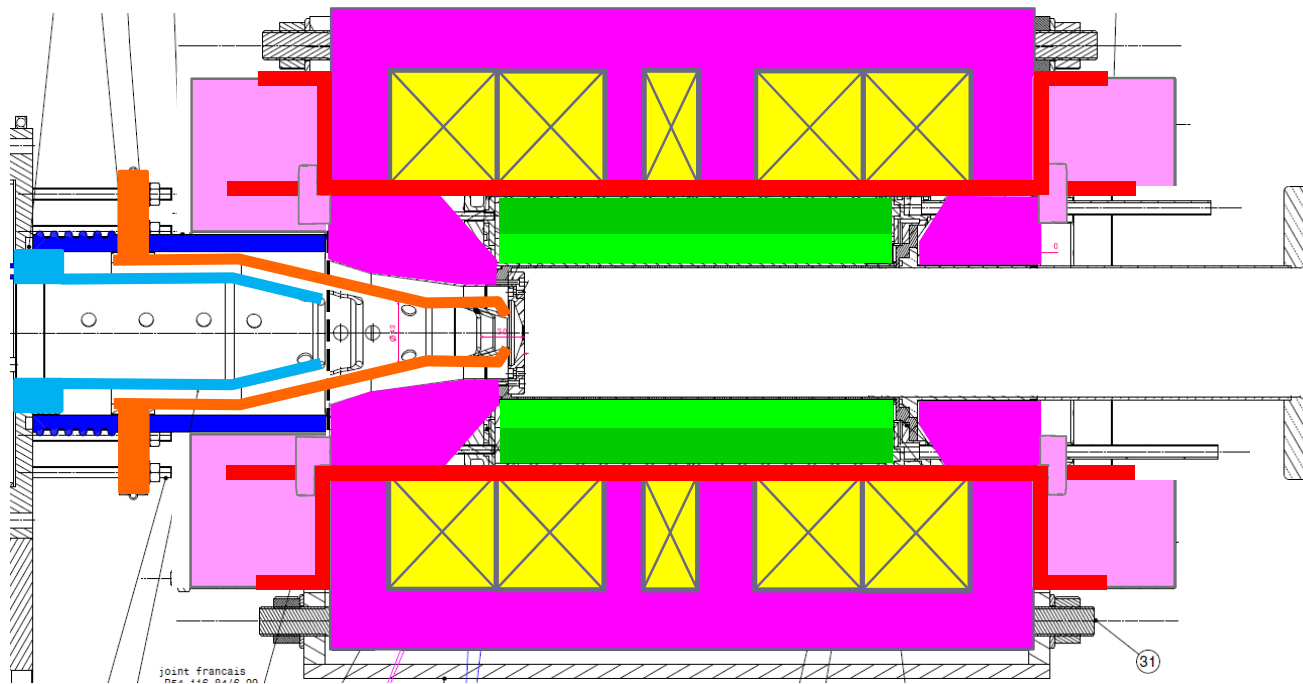

PHOENIX upgrade : V2→V3

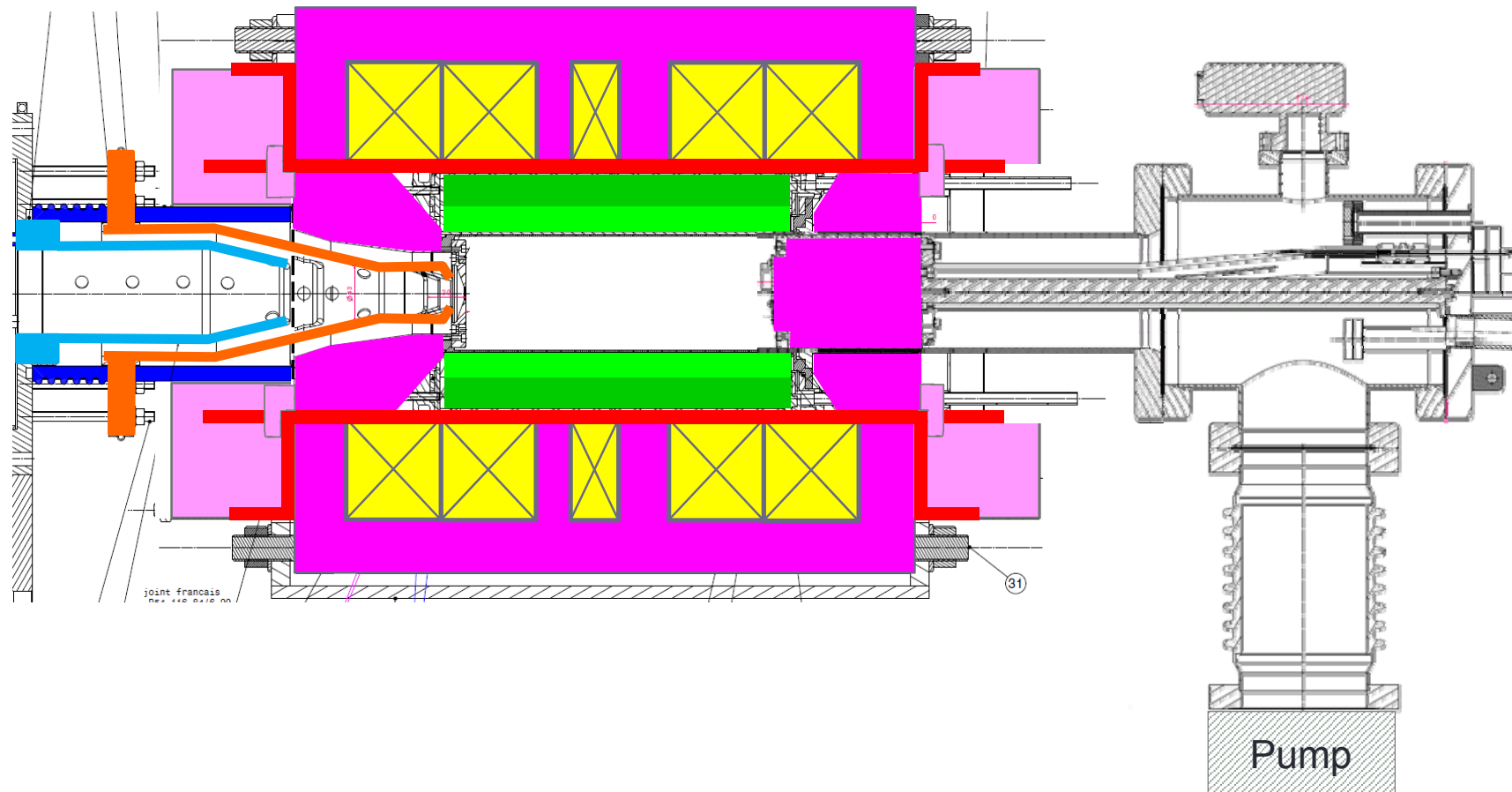

PHOENIX upgrade : V2→V3

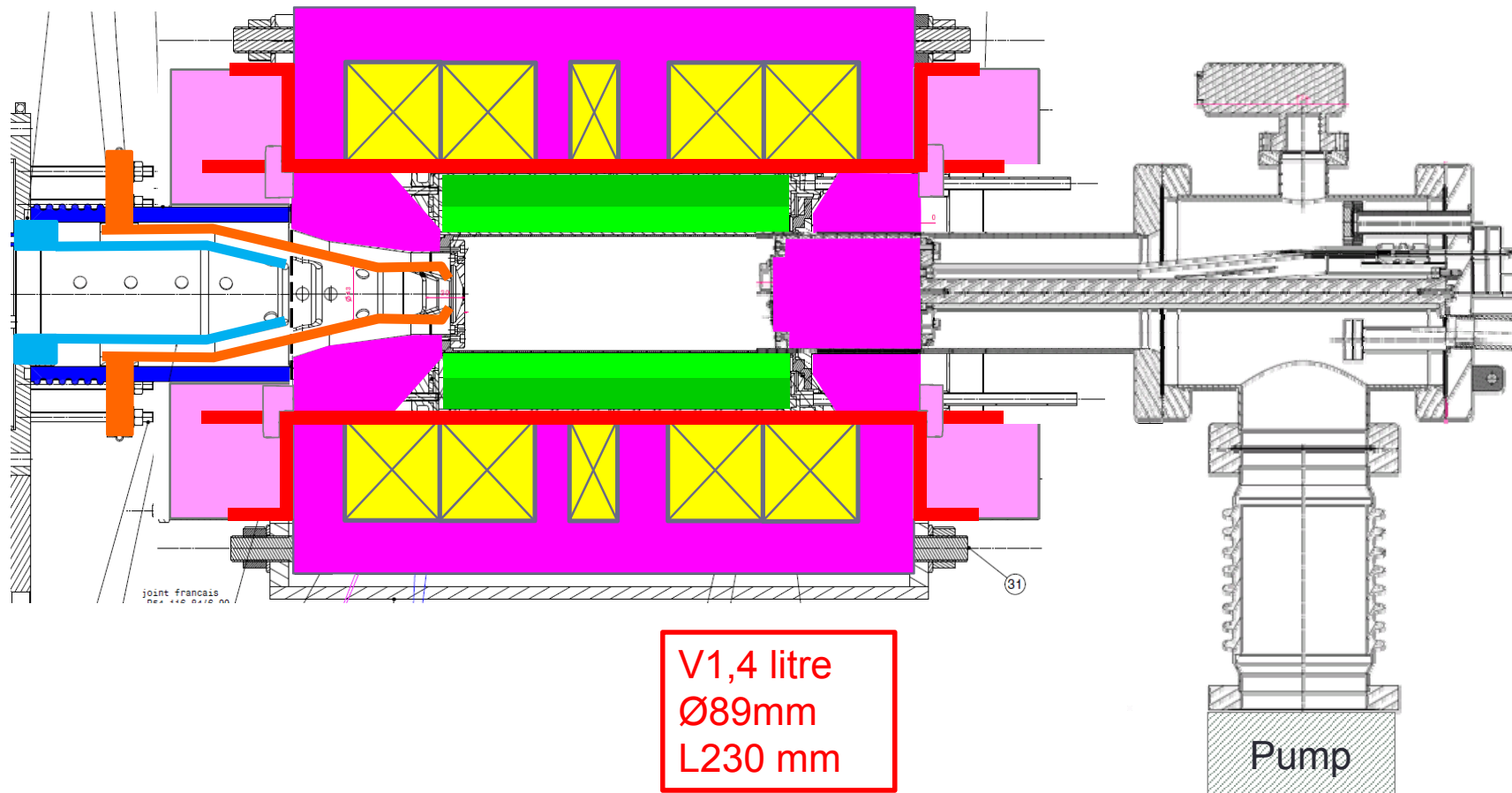

PHOENIX upgrade : V2→V3

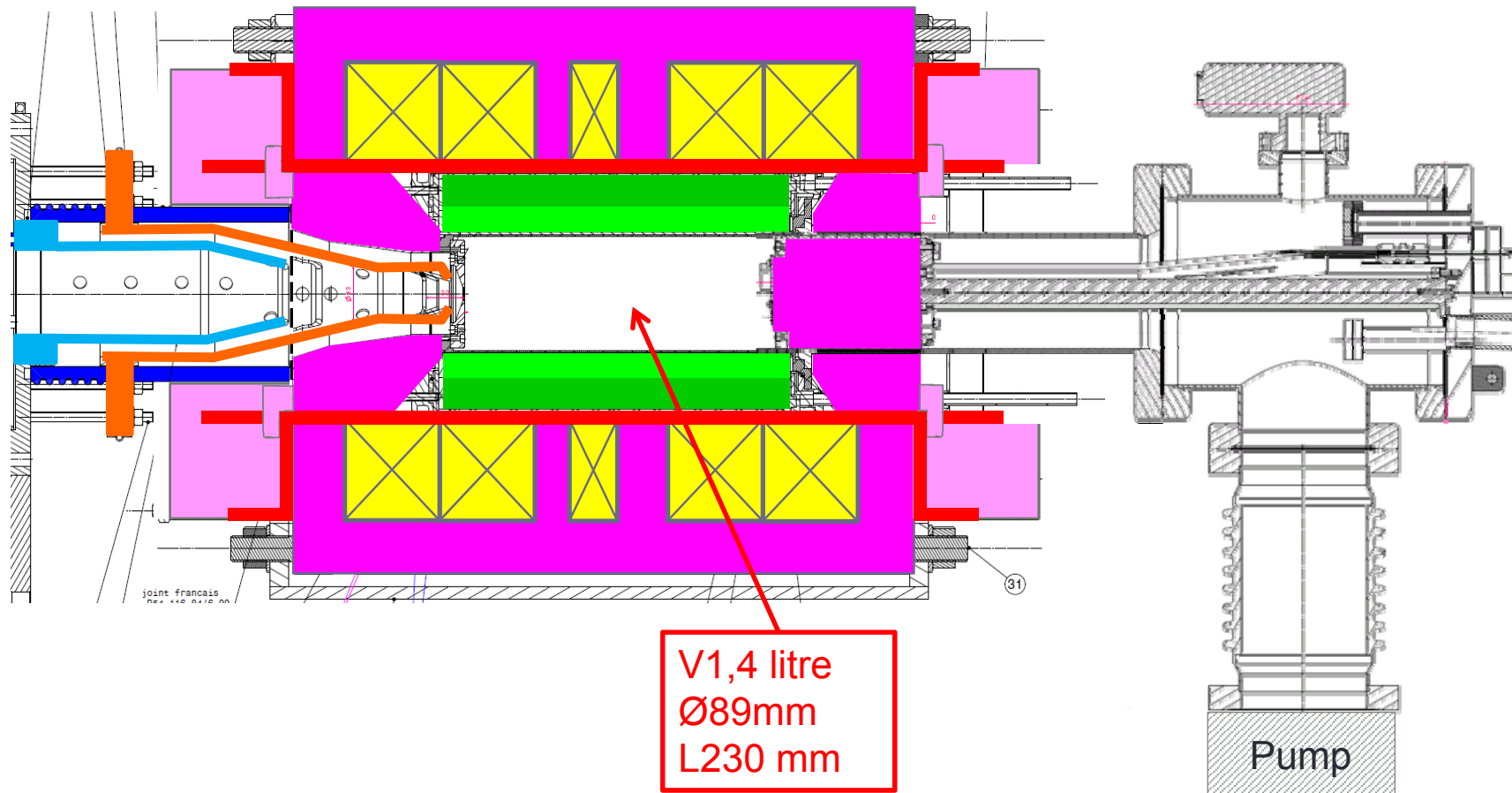

Magnetic Field

- Nearly an identical axial structure
- Almost a constant radial intensity at wall

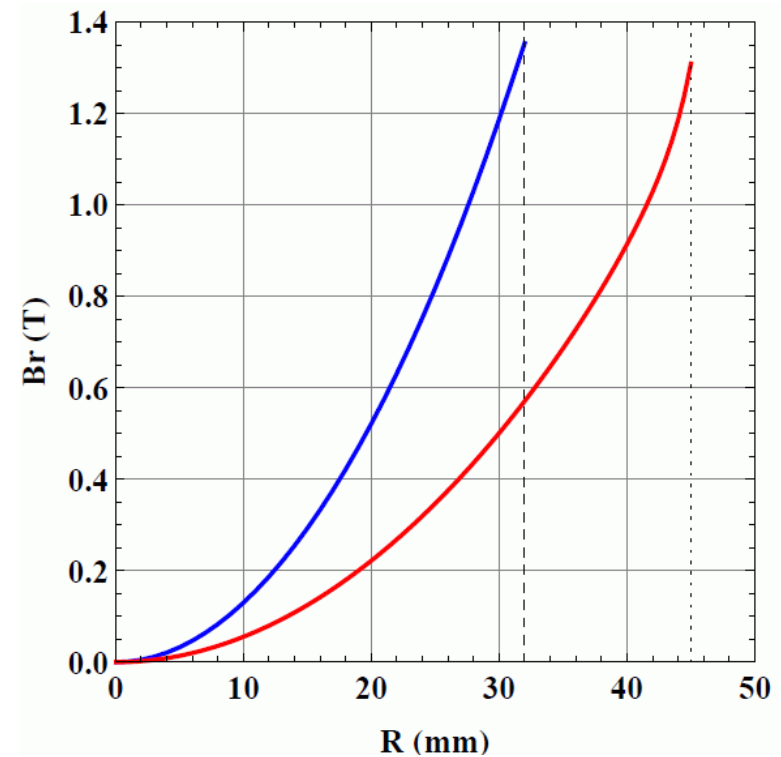
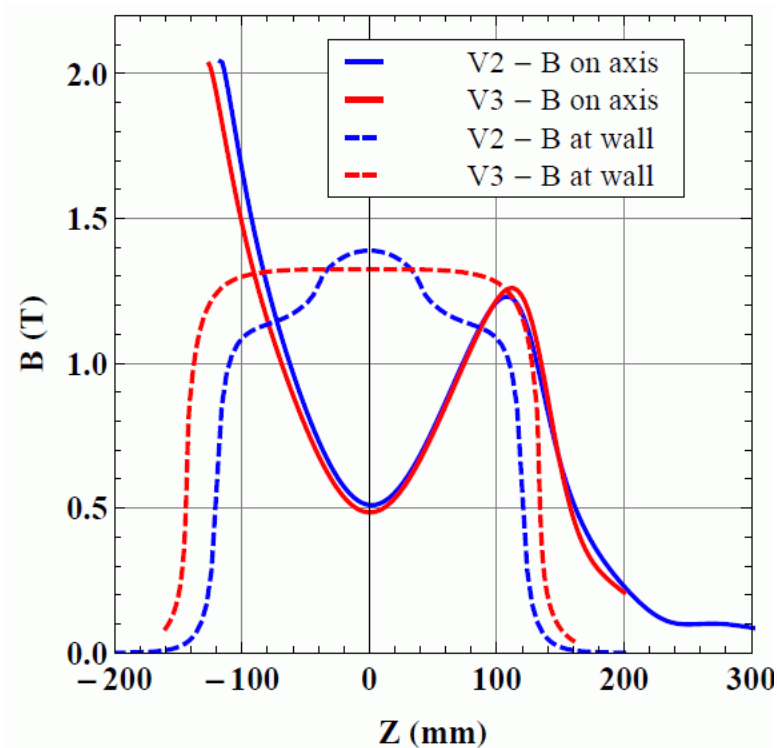

Hexapole

- Two configurations:
 - Bare hexapole $B_r \sim 1.18$ T
 - Iron strips to boost the field $B_r \sim 1.25$ T
- Nominal field measured

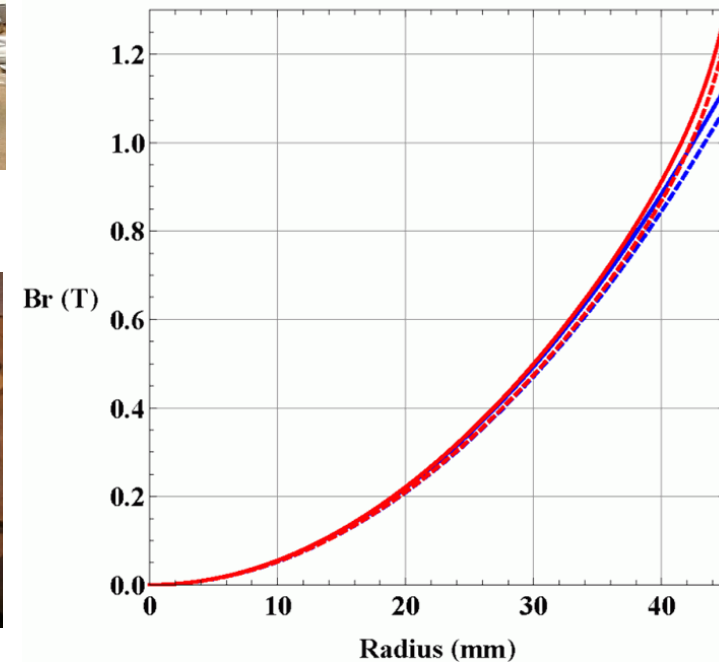
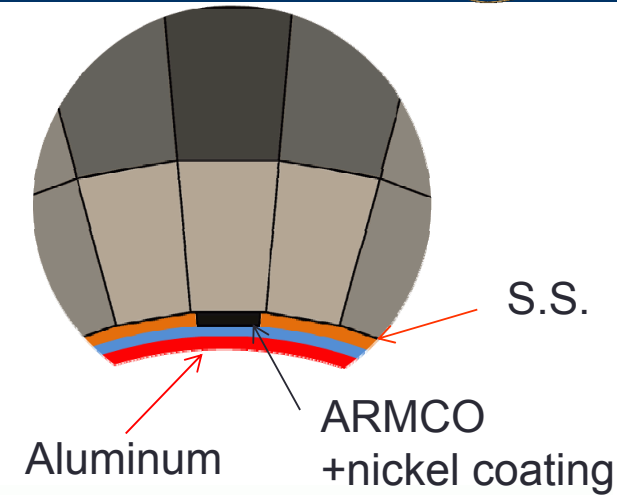
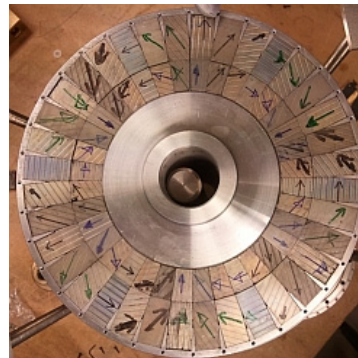
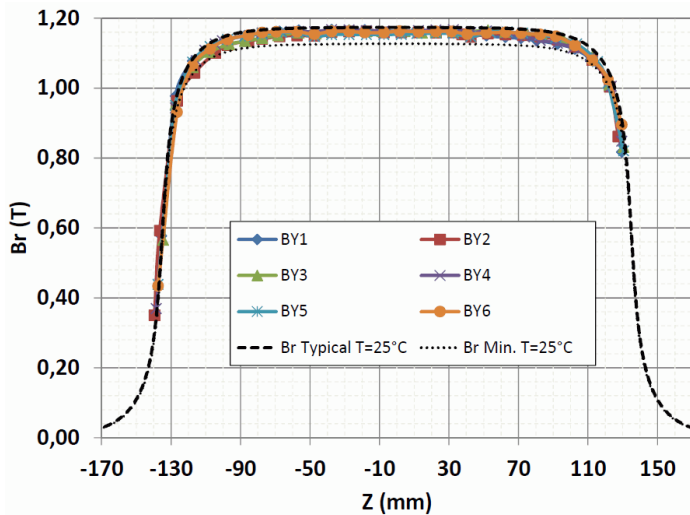

Mechanical hardware

- Injection assembly 1 (under test) :
 - Br~2T
 - Moderate pumping

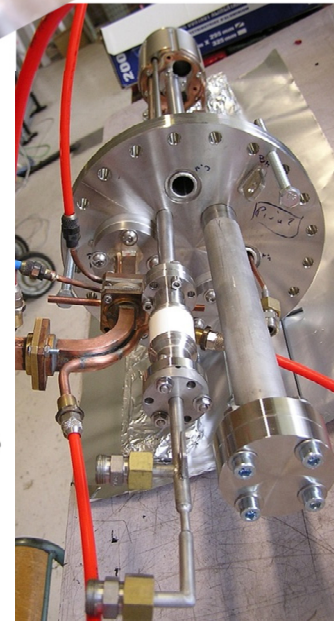
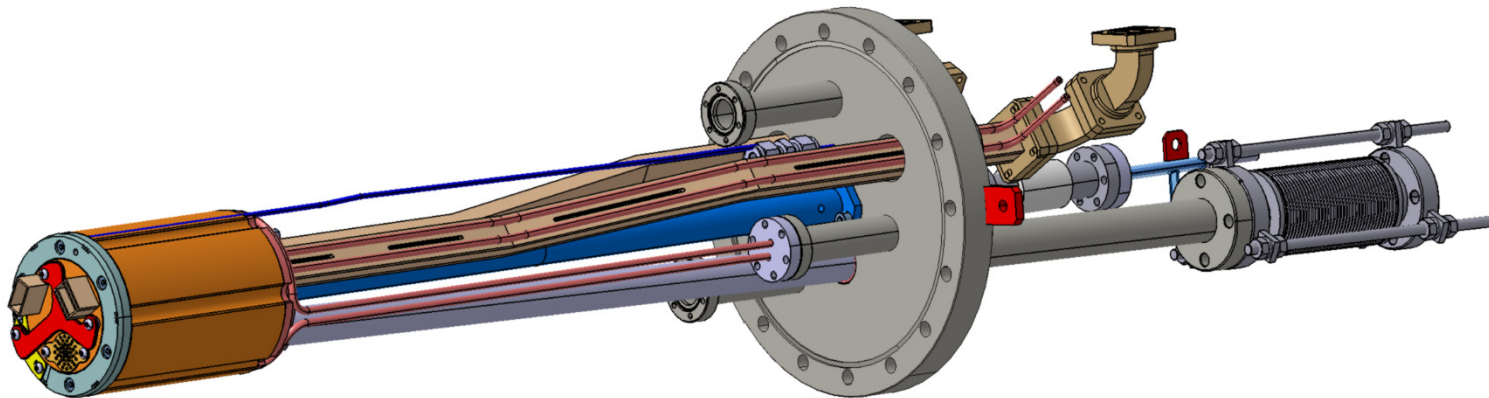
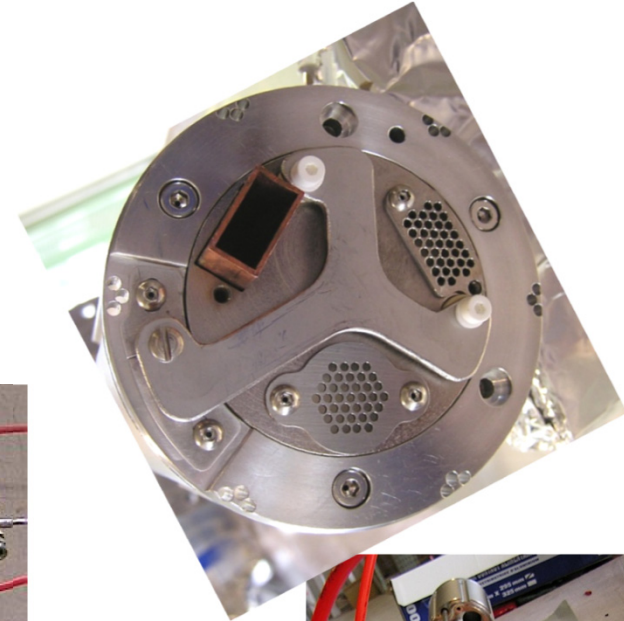

Mechanical hardware

- Injection assembly 2 :
 - Hollow iron plug $B_r \sim 1.9$ T
 - Enhanced chamber pumping

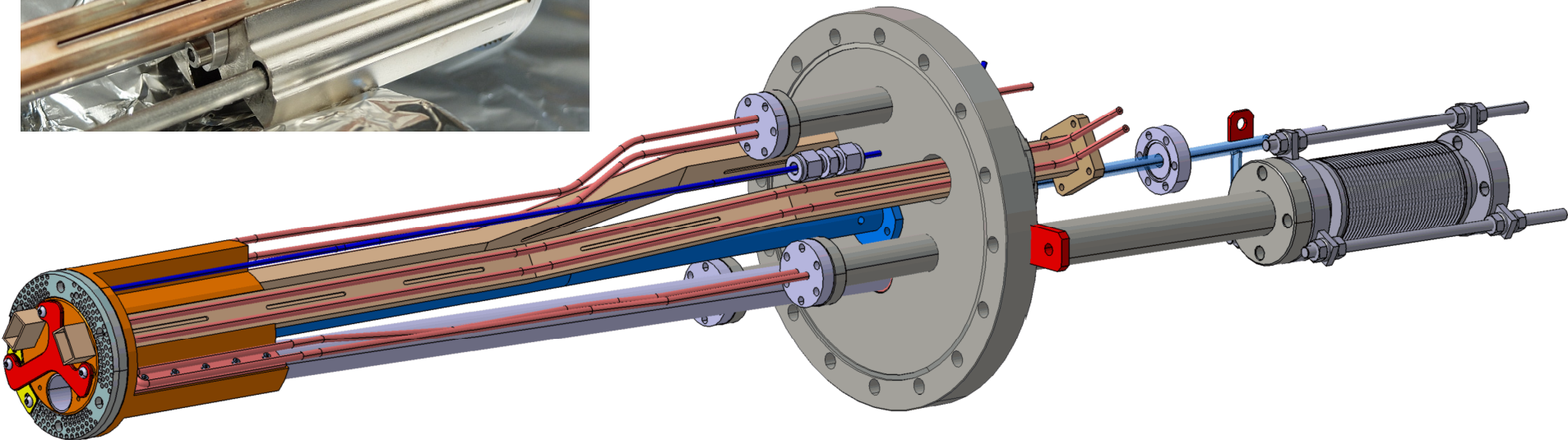
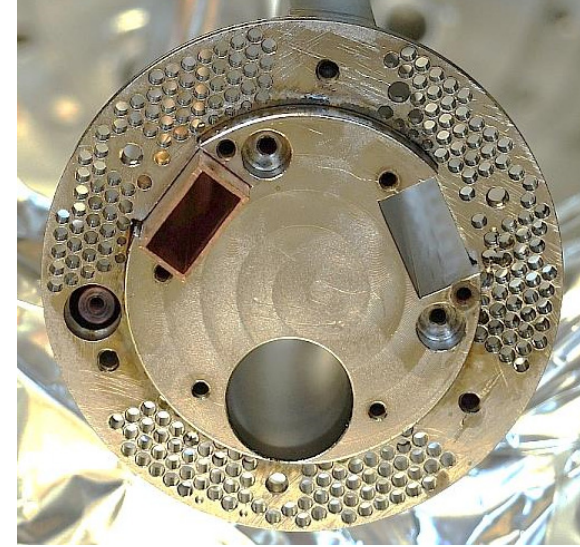
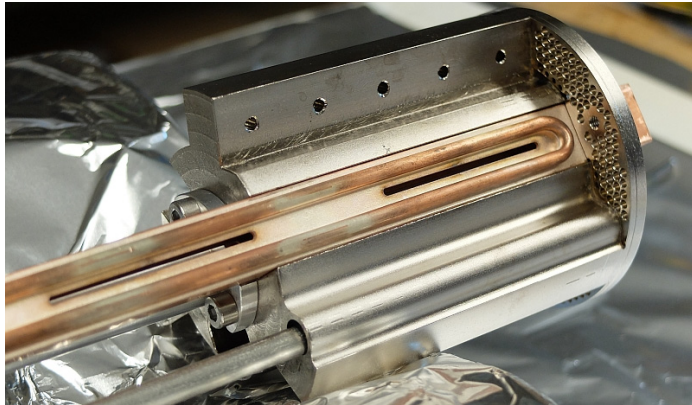

Source assembly

- Axial structure stack up
- HV core assembly in the insulator

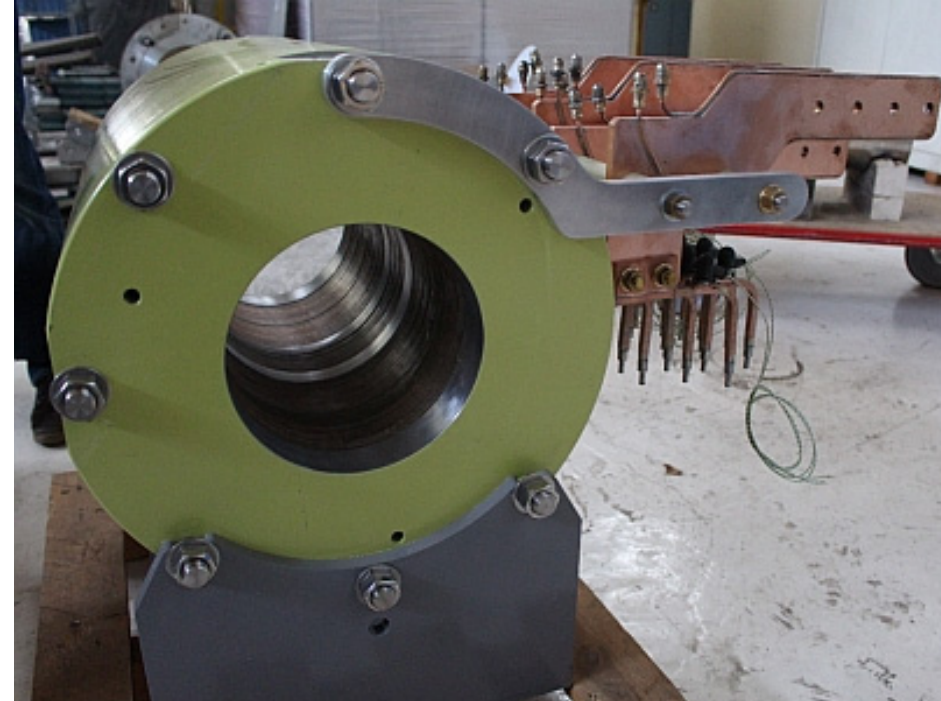
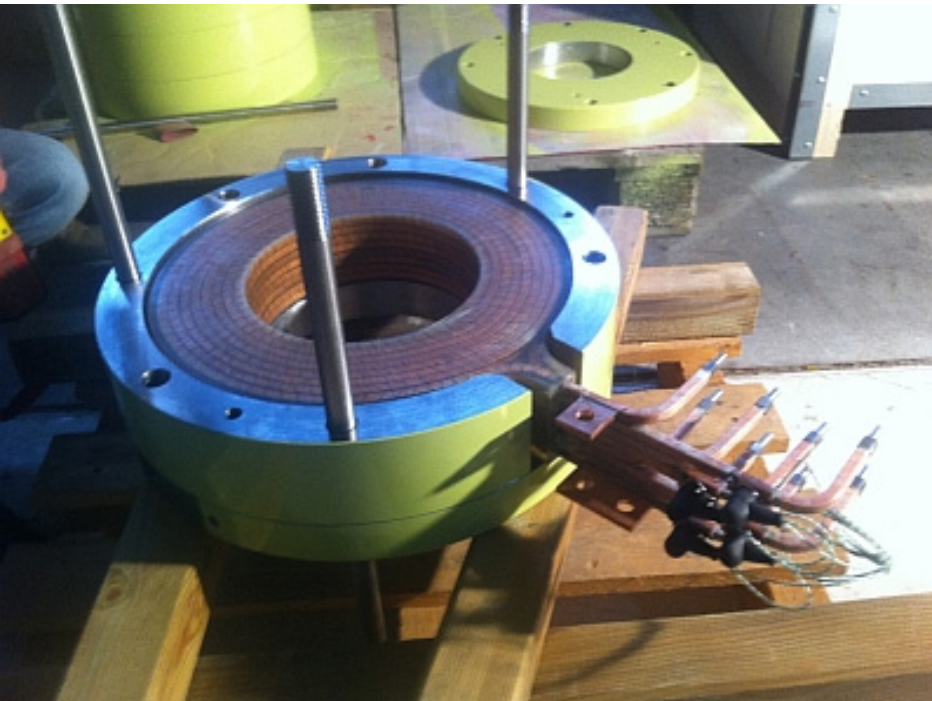
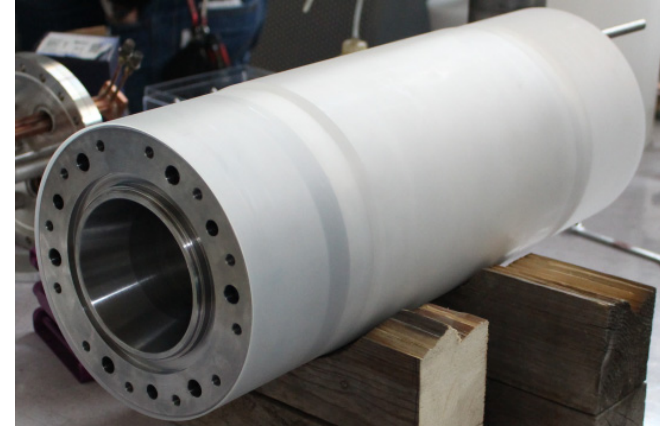

Source assembly

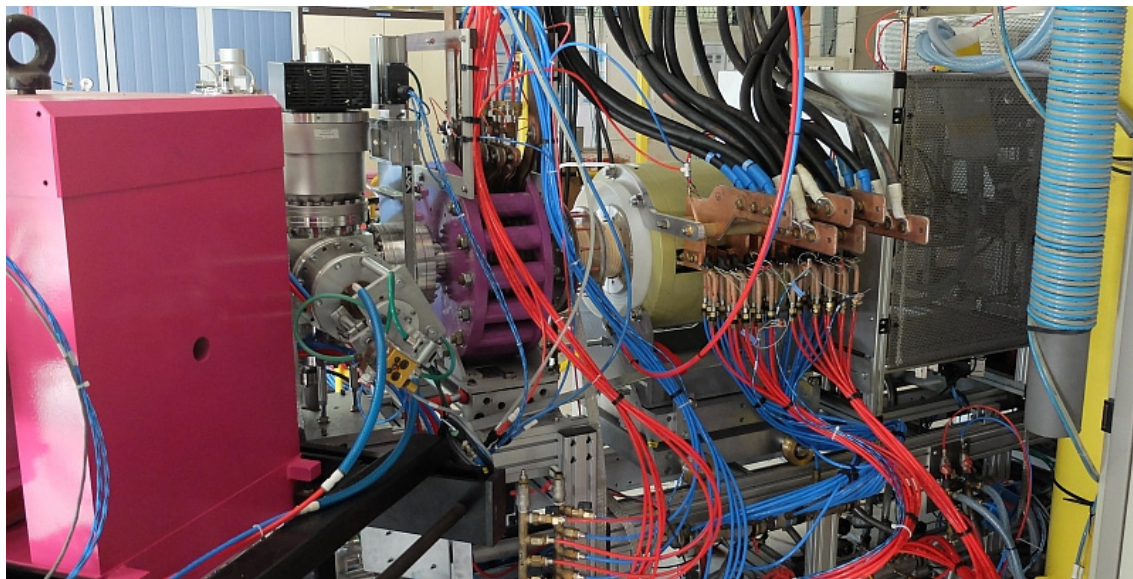

Difficult LEBT refurbishing

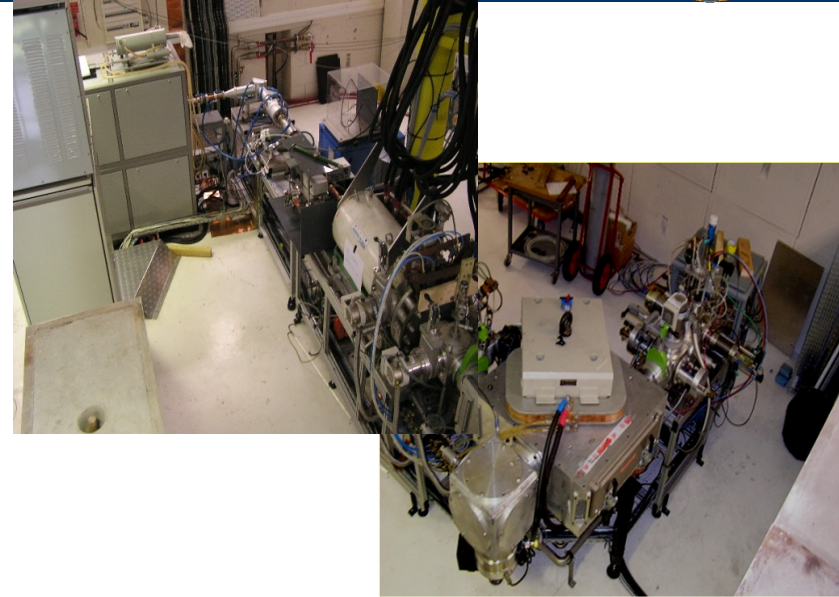

- Goal :

- Clean the vacuum part to get rid of primary oil pump contamination
- Improve the vacuum
- Use dry scroll pumps
- Improve beam optics
- Rewire the whole LEBT instrumentation
- Update the command control software

- Difficulties → Large Delay

- The LEBT industrial cleaning process turned into a nightmare
- Aluminum corrosion (0.2 to 0.8 mm pitting)...
- All the aluminum vacuum parts had to be resurfaced with sand paper!

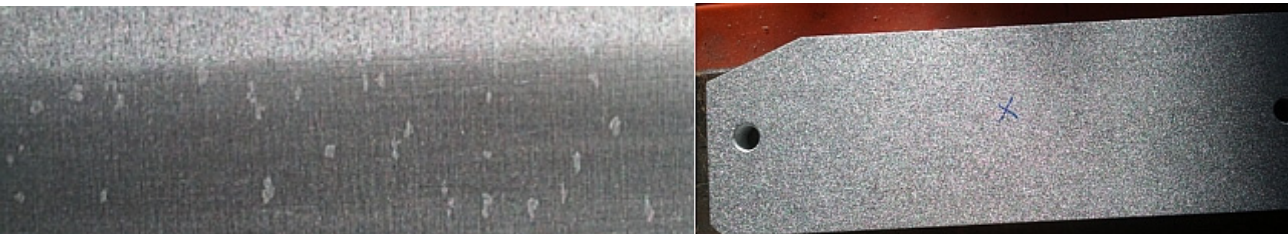

LEBT and source operational

- May 2016

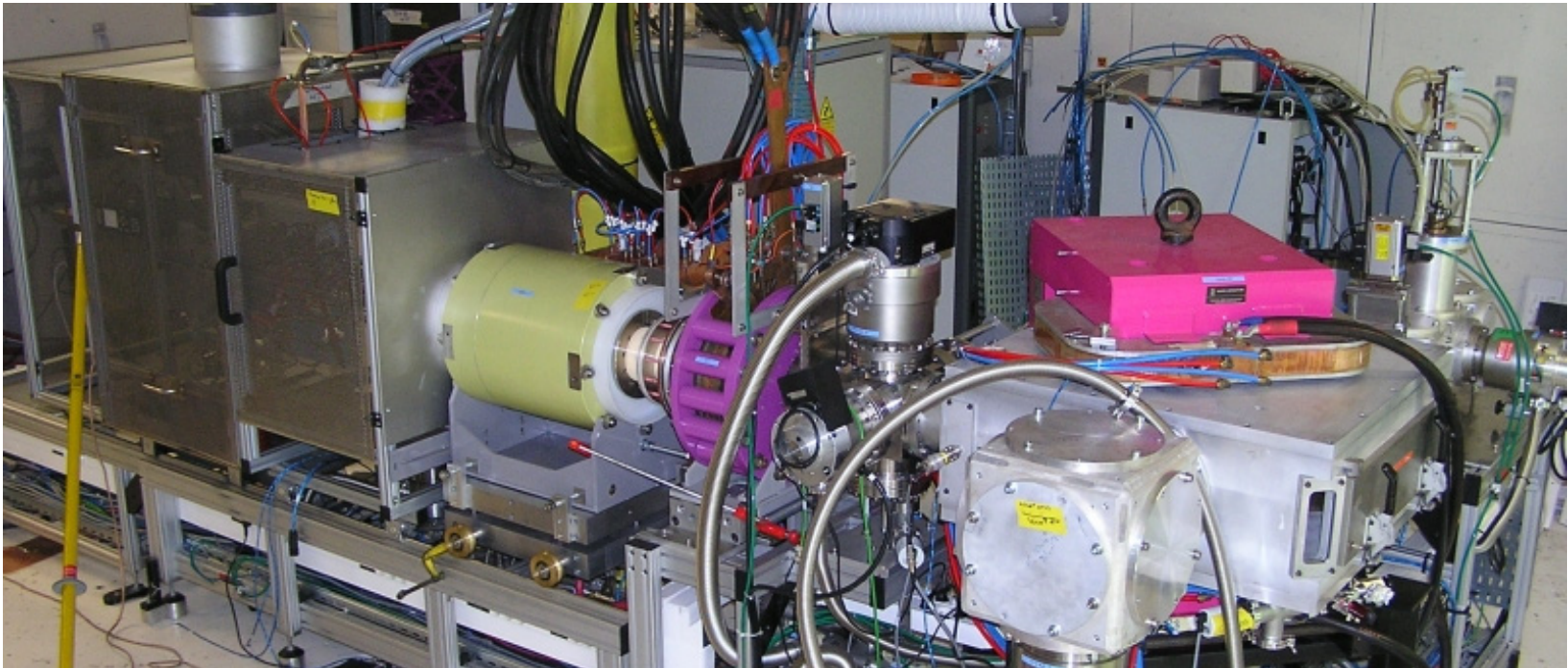

- Pressure at injection 2×10^{-8} mbar
- Pressure at extraction 6×10^{-8} mbar

LEBT and source operational

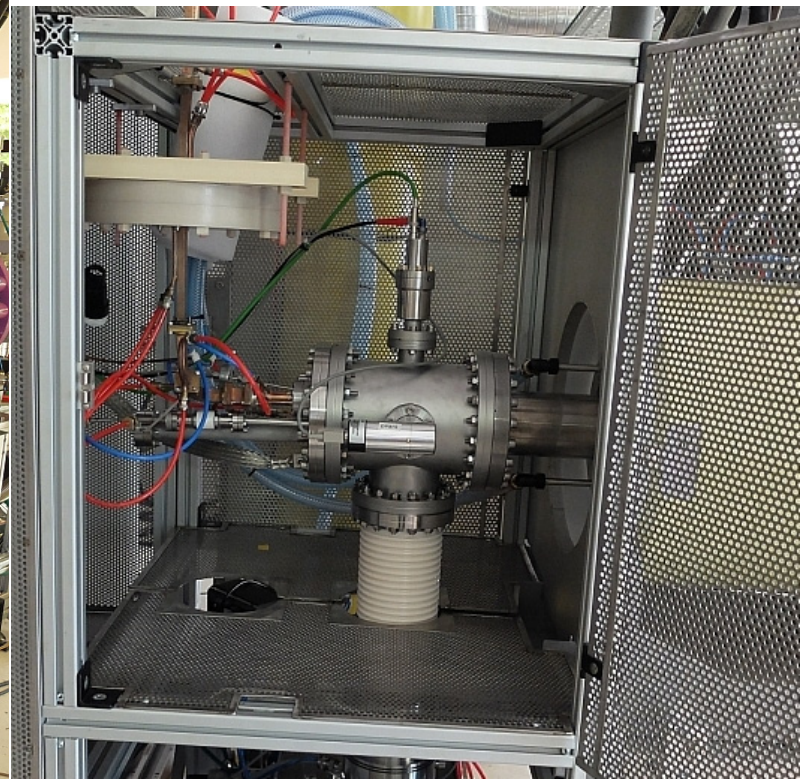

Plasma chamber modification

- A check before igniting the plasma revealed an insufficient water cooling of the chamber!
 - Experimental Water velocity was too slow
 - $Re < 2500 \Rightarrow$ laminar flow...
- Hot electrons simulation was done to locate the heat deposition
- The chamber mechanics was modified to increase the water velocity along the poles
 - $0.5 \times 10 \text{ mm}^2$ slots
 - $v = 11 \text{ m/s}$ in each channel
 - $Re \sim 10000 \Rightarrow$ definitely Turbulent

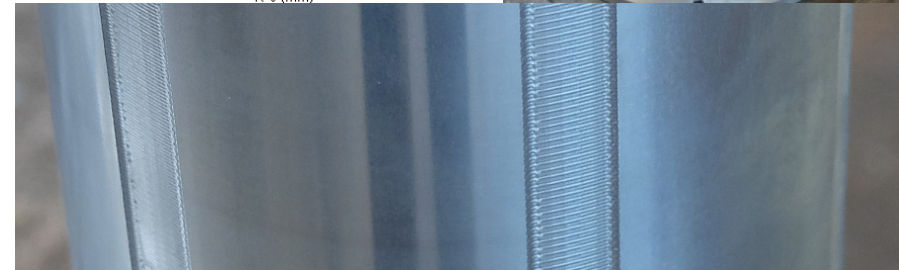
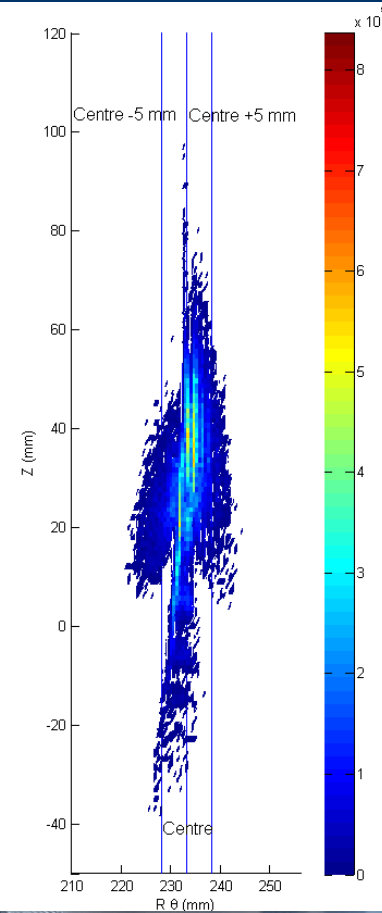
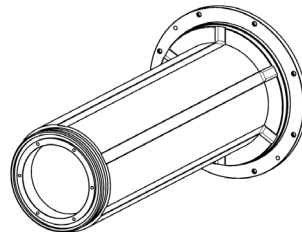

1st PHOENIX V3 plasma

- May, 9th 2016
 - 30 kV, low RF (to prevent any damage to the hexapole)

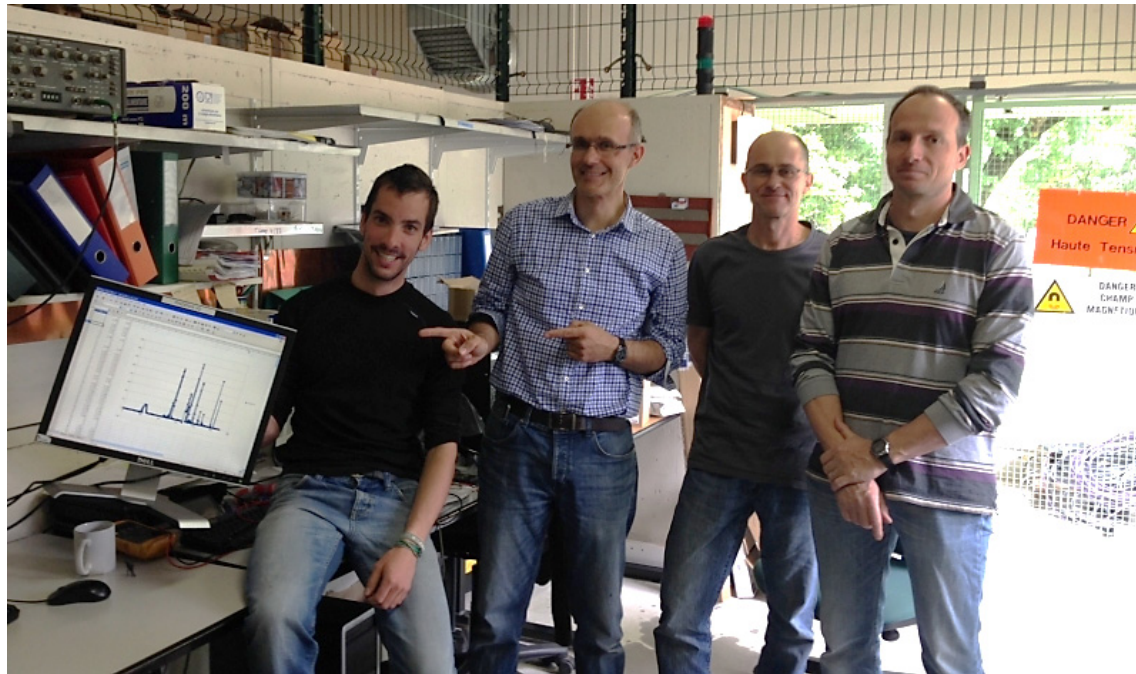

- New Plasma chamber installed in late July 2016
 - ~10 days of commissioning since

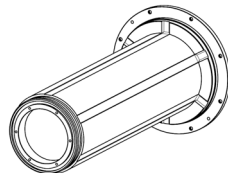

Low power commissioning under progress

- The source commissioning is normal so far
 - The RF coupling looks ok
 - The plasma mean charge state is enhanced with respect to V2
 - 45 kV reached (goal is 60 kV)

Argon spectrum – 180W RF – low pressure

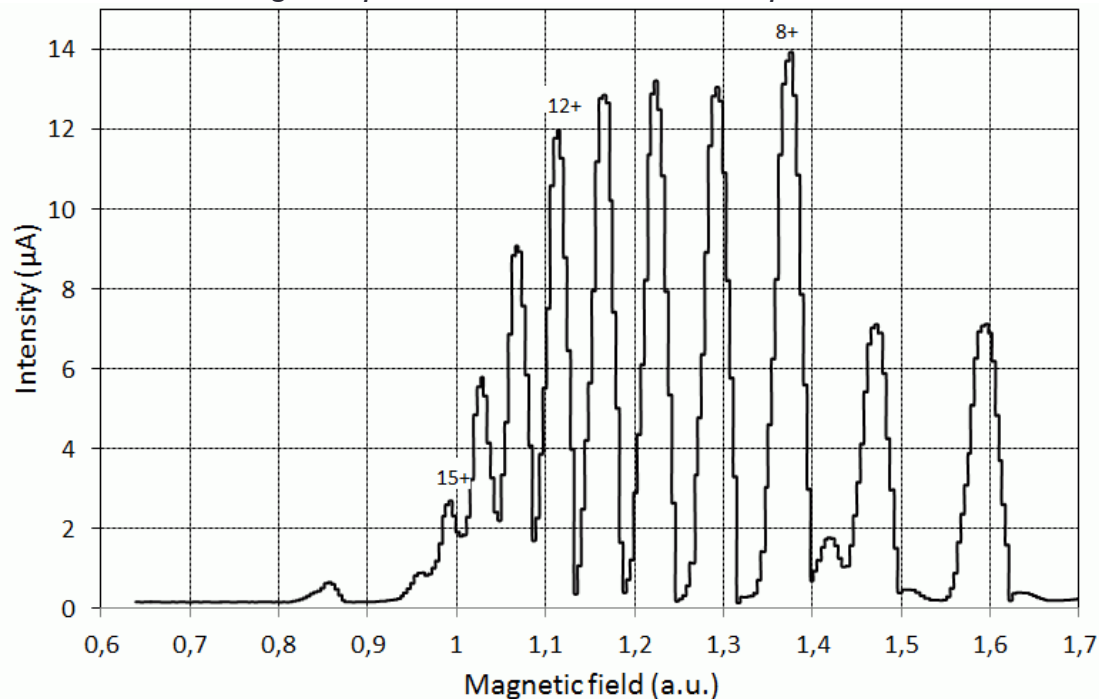

Low power commissioning under progress

- The source performance is improving with time...
 - As of today @ 300 W RF: 110 $\mu\text{A Ar}^{12+}$, 450 $\mu\text{A Ar}^{8+}$, 400 $\mu\text{A O}^{6+}$
- Limitation by the 3 magnetic field power supplies
 - 35 years old , unused for 3 years, unable to deliver their nominal intensity (1100A instead of 1300A)
 - To be maintained soon

Finger crossed for the coming
Tests!

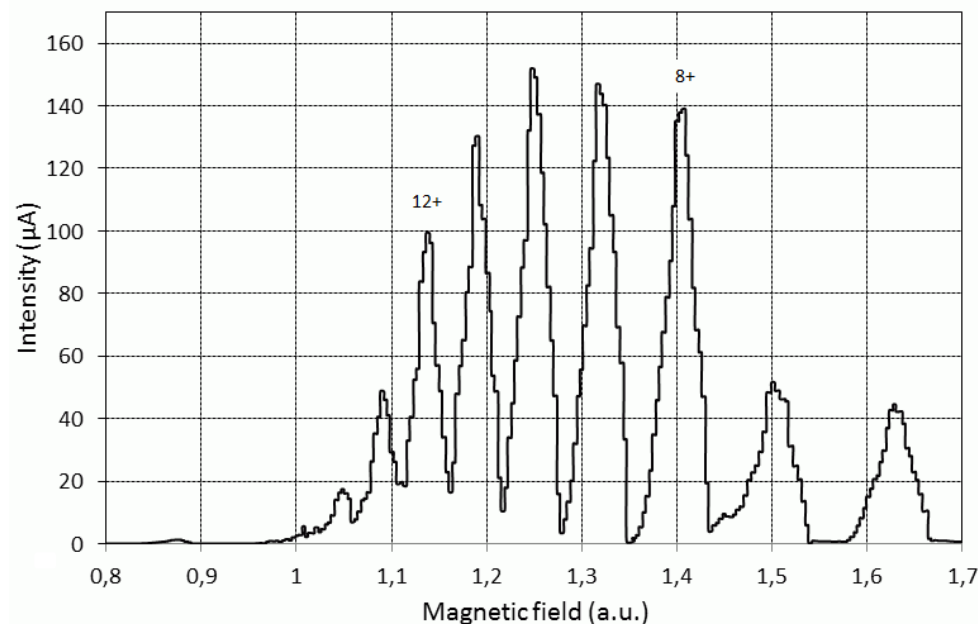

THANK YOU FOR YOUR ATTENTION !

여러분의 관심 에 감사드립니다

Updated beam requirements for S³

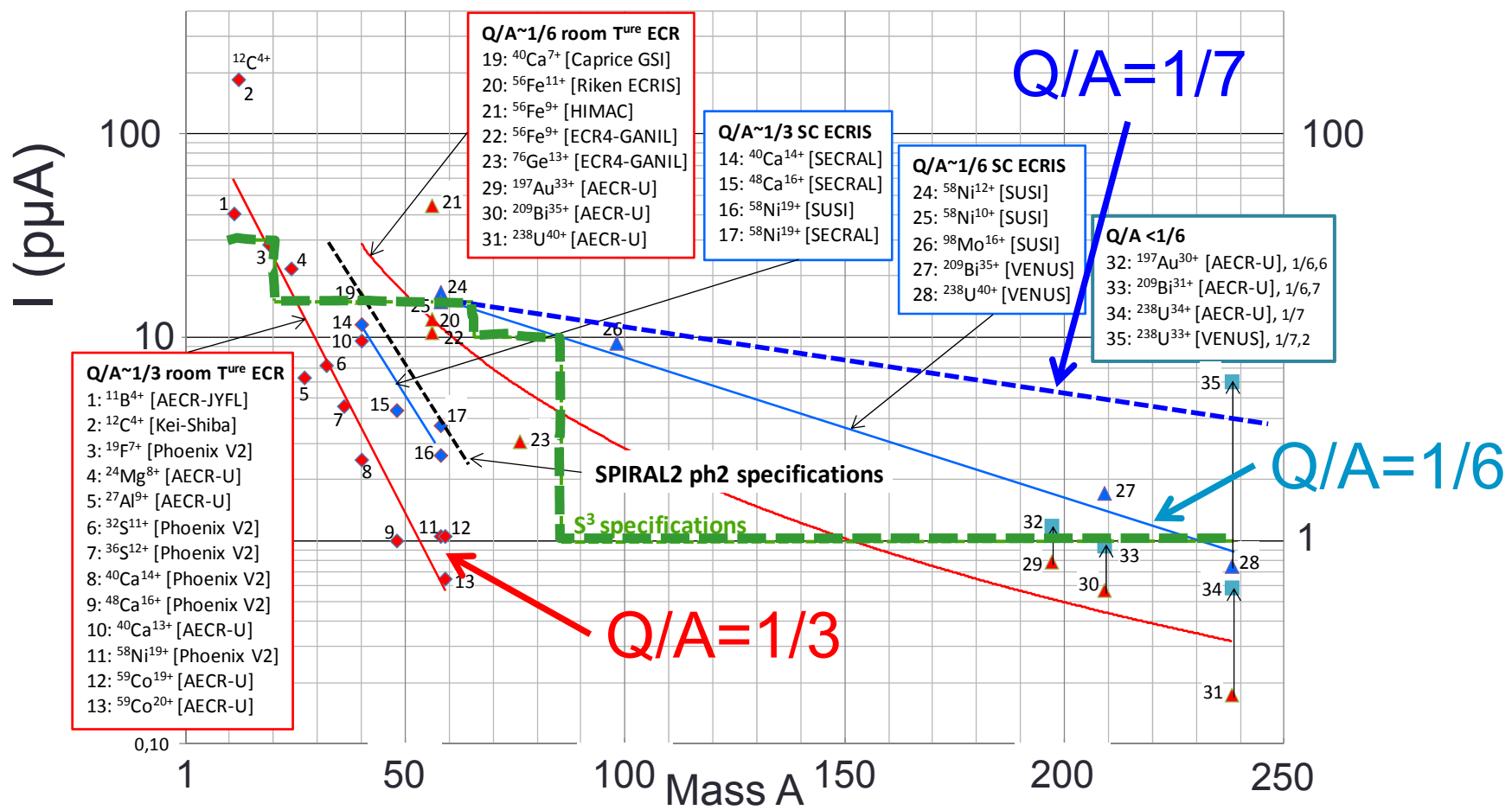

C. Barué plot, ICIS 2013

LEBT transport investigation

- Oxygen « flat spectrum »

- High charge state transmission higher than low charge state
- An indirect evidence that high charge states are extracted on smaller radius

