

Introduction

NA61/SHINE is a fixed target experiment in the North Area of the Super Proton Synchrotron (SPS). NA61/SHINE studies the hadron production in hadron-nucleus and nucleus-nucleus collisions. The aim of this experiment is to study phase transitions in strongly interacting matter (quark gluon plasma), the onset of deconfinement and to take reference measurements for the hadron production.

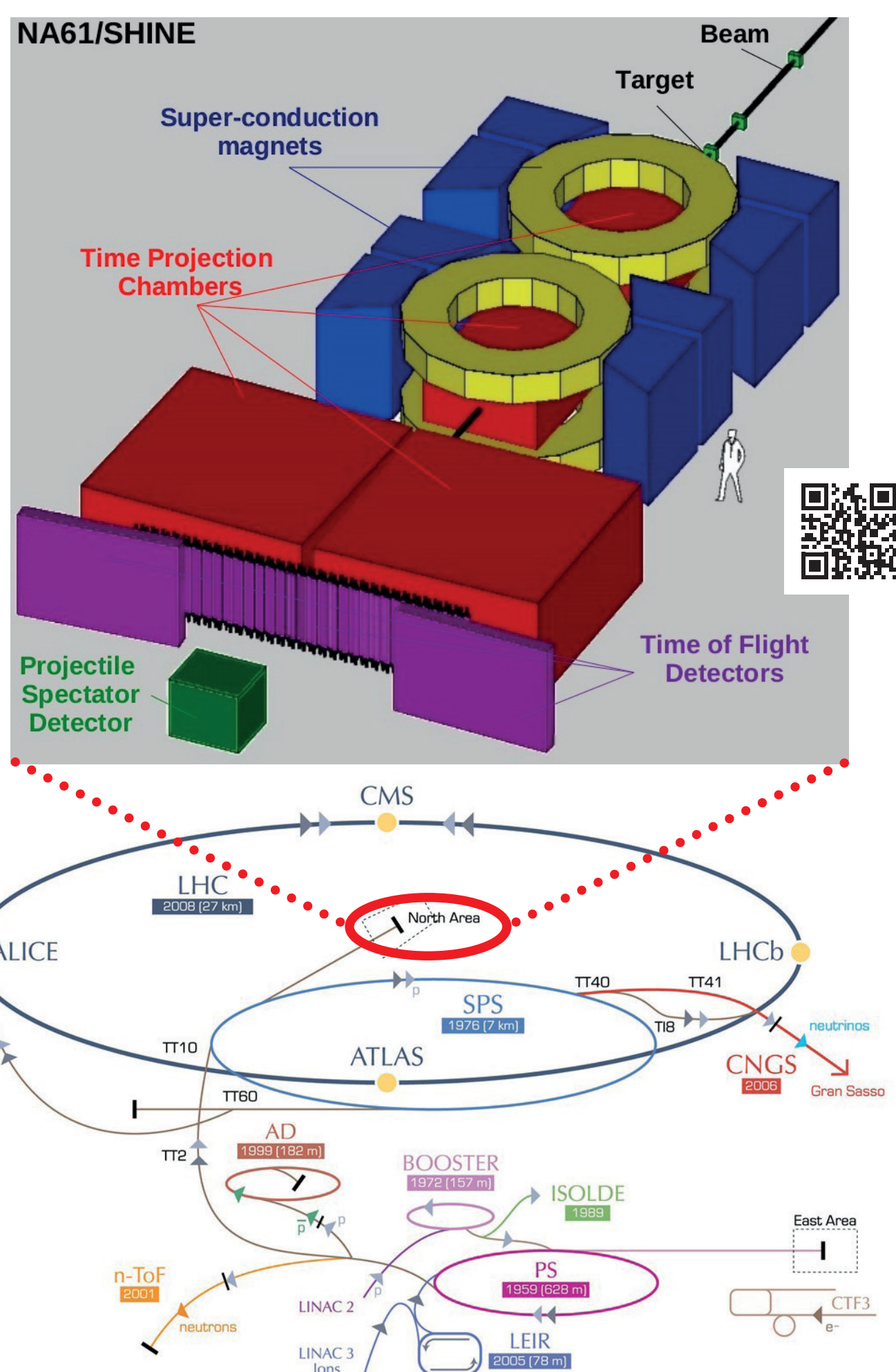

In the last years proton and lead as primary beams and light ions from fragmented beams were used. In 2015 a primary argon beam was delivered to be able to explore a wider range of energies and densities in the experiment. In preparation the accelerator chain was set up with the argon beam in the second half of 2014.

In 2013 a test run was done at the linear accelerator Linac3 to find and optimize the settings for the source and the linac, to measure the beam parameters (intensity, stability, emittance) and to study the long term behaviour of the source and the linac.

As the first tests in 2013 showed already after 10 weeks of operation some degradation of the source hardware, it was decided to do a preventive maintenance after roughly 6 months of operation where plasma chamber and extraction system were replaced with spare parts.

GTS-LHC and linac parameters

microwave frequency	14.5 GHz
operation mode	afterglow
microwave pulse length	50 ms
repetition rate	10 Hz
extraction voltage	9.6 kV (2.5 keV/u to match RFQ input)
final linac energy	4.2 MeV
ion	$^{40}\text{Ar}^{11+}$
support gas	-
ion pulse length	200 μs
ion current from the source	100 μA
ion current from the linac	70 μA
intensity variation	<20%
operation period	~12 months, 24/7

Charge state distribution

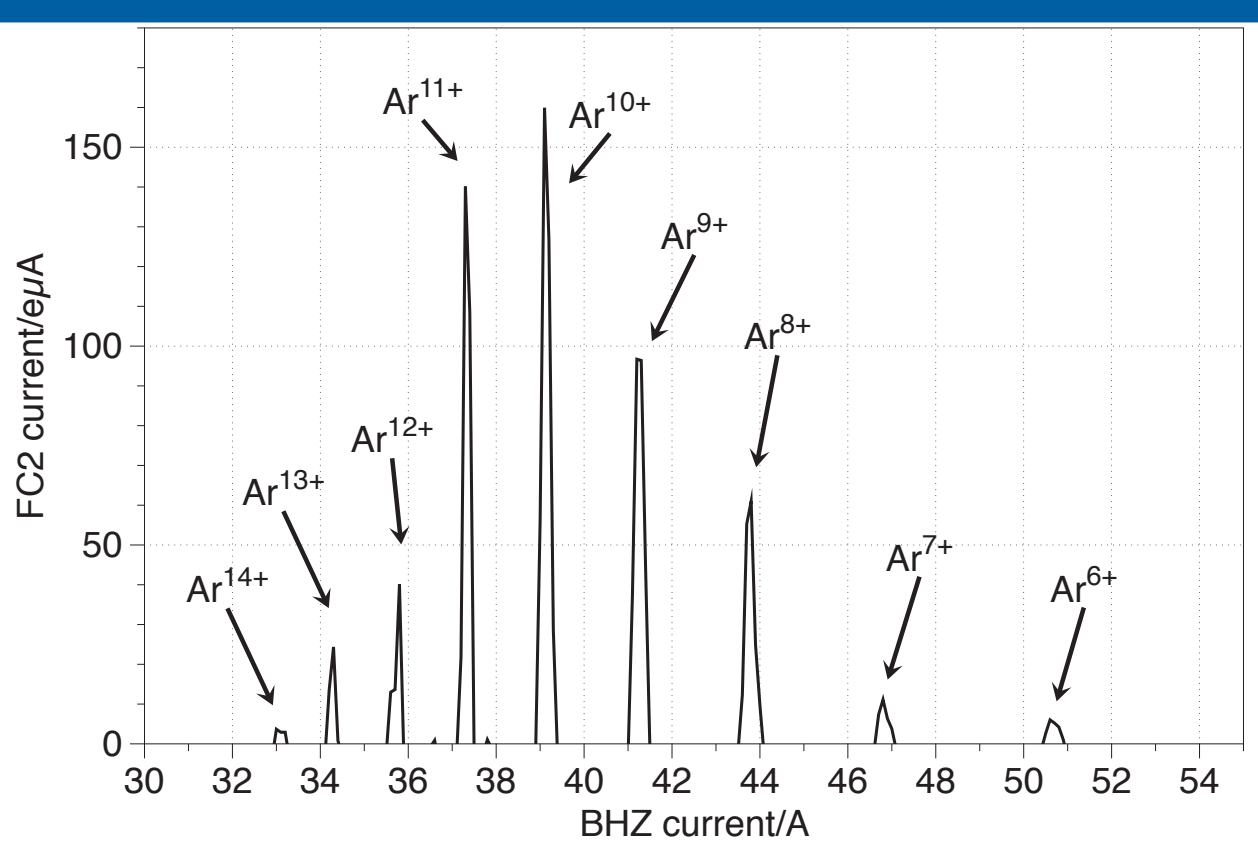

Investigations

Operating with argon the source can be tuned to a stable operation point (more stable over long periods than during Pb ion production) and also returns to the same conditions quickly after a source stop. The fixed target physics programme was limited by event pile up, and therefore high intensities were not requested from the accelerator chain. Therefore the tuning of the source could also be made with low power parameters (for example the ECR source microwave power was kept below 500W). This allowed to reduce the hardware degradation (known from the 2013 experiment) and to maximize the source lifetime.

The different parts of the source and the linac were affected by the argon operation in different ways. The three main issues are shown here.

The plasma chamber

In 2013 already after 10 weeks of operation first sputter marks could be seen in the plasma chamber and in the ion beam co-extracted iron ions could be found.

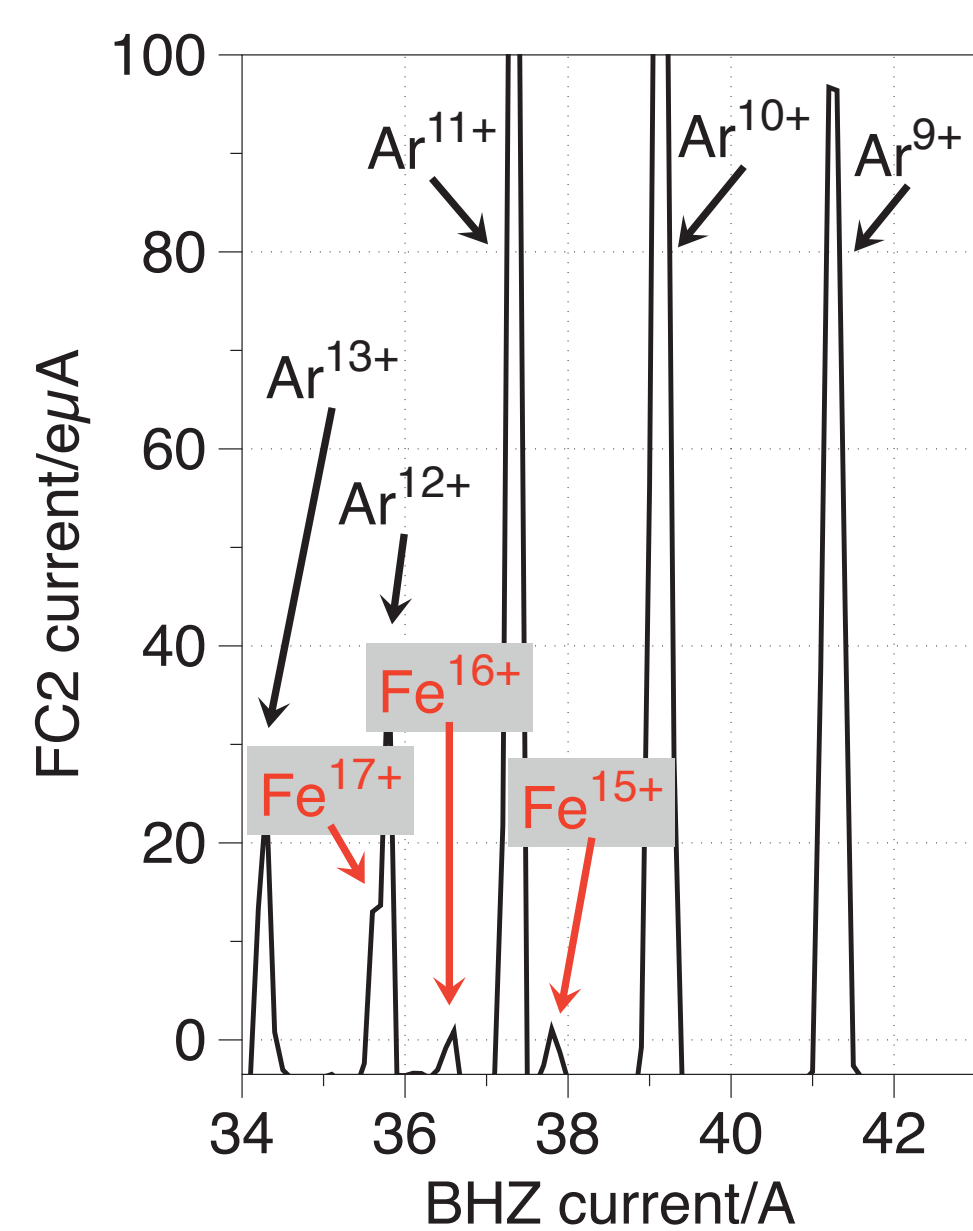

After a period of 6 months the plasma chamber was taken out and measured. The spots where the plasma is lost dominantly are clearly visible and along these loss lines grooves up to 100 μm deep were measured (the chamber has a wall thickness of 2mm). During the lead operation only some marks were visible at the same spots.

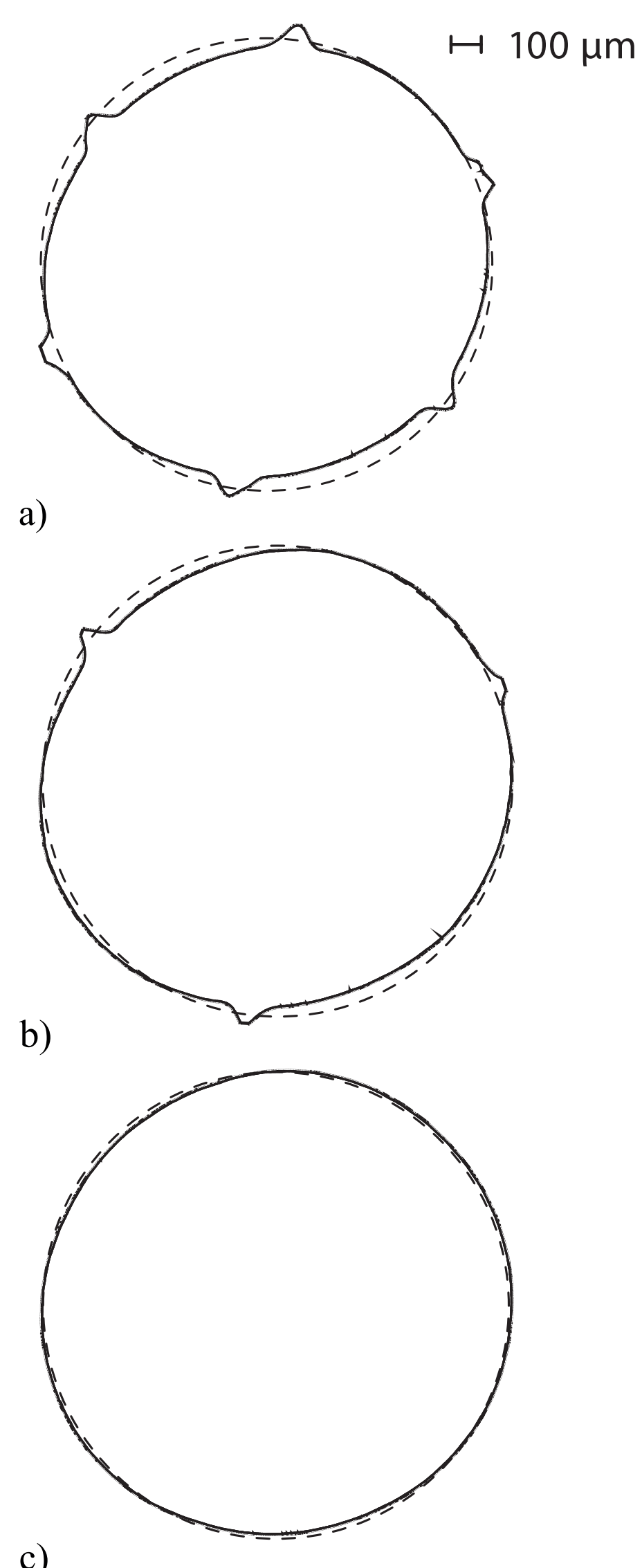

The measured deviation of the plasma chamber surface from the ideal circle (dashed). The values are amplified by a factor 100. The inner diameter of the chamber is 78 mm. The measurement was taken a) roughly in the middle of the chamber, b) at around a quarter of the chamber length and c) at the extraction end of the chamber.

The extraction system

The GTS-LHC source operates with a 3 electrode extraction system. After the replacement of the extraction system during the maintenance two observations could be made.

The aperture of the intermediate electrode showed clear sputter marks and some metal flakes after removal from the source.



The insulator between the intermediate and the ground electrode was partially metallized on the side which is facing the extraction aperture.

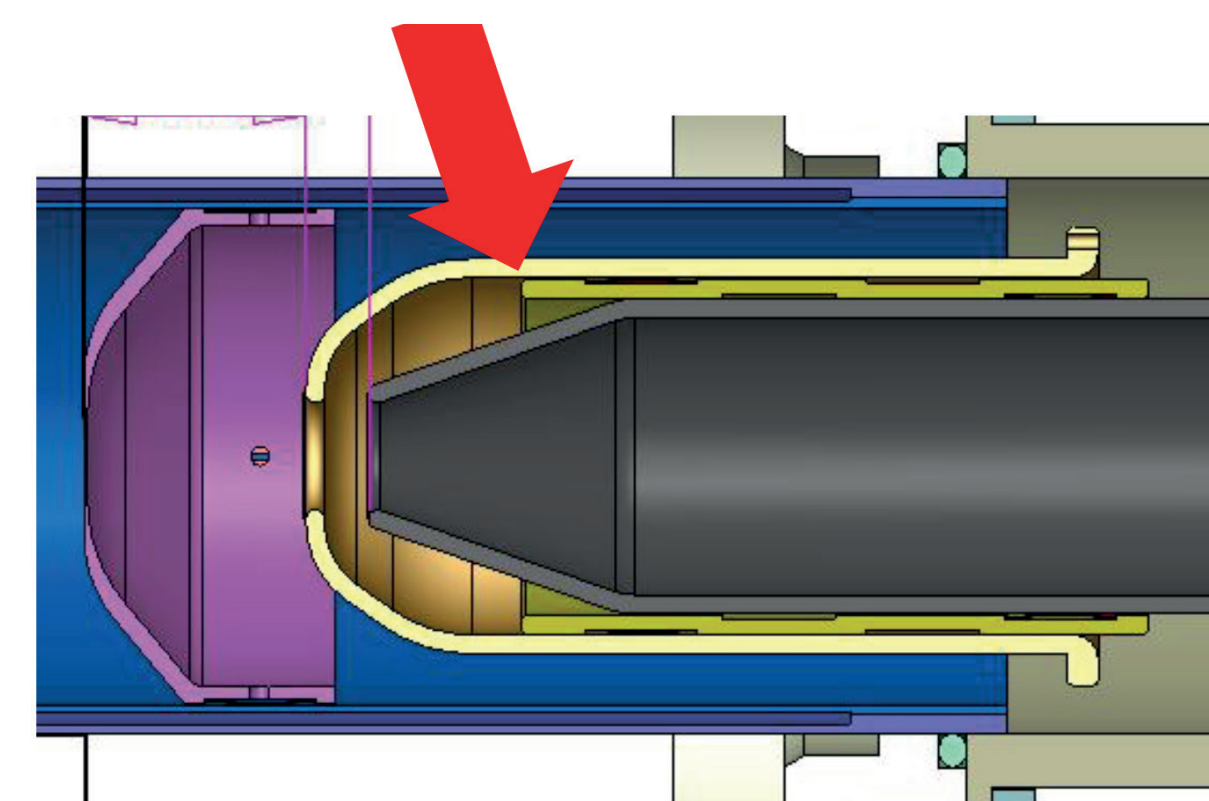

The top part of the figure shows the position of the insulator and the side of the metallization. The electrodes from left to right: plasma electrode (purple), intermediate electrode (yellow) and ground electrode (grey). In the lower part of the figure the left insulator shows a clear metallization on the top after around 6 months of argon beam operation. The right lower part shows for comparison an insulator that was used around 8 months during lead beam operation.

An indication that there is some metallization of the insulators was there already during the operation. It could be seen at the behaviour of the current of the extraction high voltage. While the extracted ion current stayed quite constant and therefore also the fraction of the high voltage current related to the ions drain current went up over time. The change of the high voltage current was relatively constant most of the time and could be fitted with a cubic function. Why it is a cubic function is not well understood.

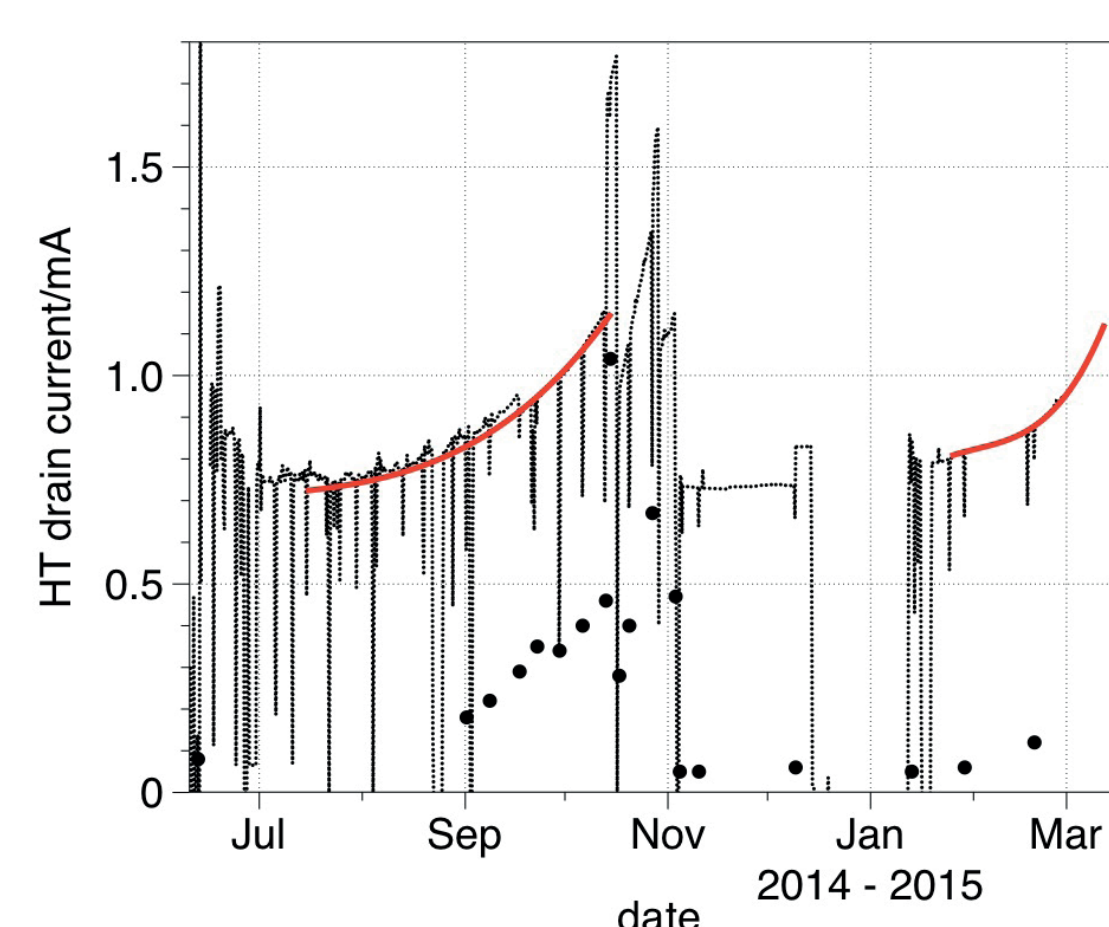

The current of the extraction power supply. The dotted line is the total current when the plasma is on, the dots show some selected values of the drain current when the plasma is off. The red curve represents a cubic fit of the current. In November there was the source maintenance. Due to the clean insulators the drain current dropped down, but over time started to rise again.

The vacuum system

The vacuum in the linac is maintained by ion getter pumps. There are 4 pumps in the LEBT and 2 at the RFQ. Only at the source and at the first diagnostic box after the source there are in addition turbo molecular pumps.

During normal operation the pressure in the linac is in the order of 10^{-8} mbar. Only in the source extraction region and in the first part of the Low Energy Beam Transport (LEBT) it is in the order of 10^{-7} mbar.

During the running period it was realized that while the pressure in the linac stayed quite constant the current in the ion getter pumps was rising. The effect was very pronounced in the LEBT but could be seen also in the ion getter pumps of the RFQ. This behaviour is not fully understood, but it may be related to leakage currents inside the ion getter pumps due to the coating of insulators.

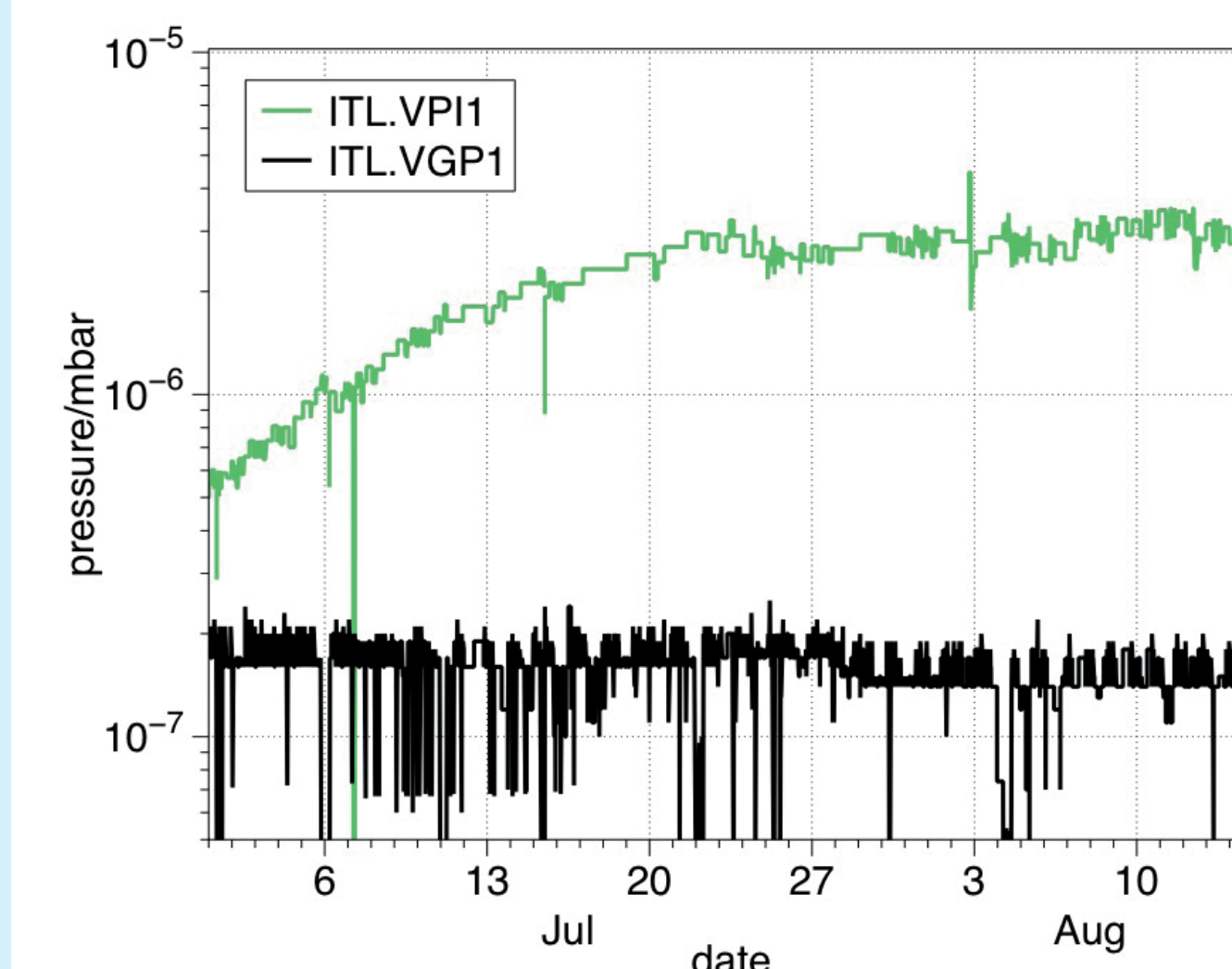

Vacuum measured in the LEBT with a Penning gauge (ITL.VGP) and in one of the ion getter pumps in the LEBT (ITL.VPI). The current measured in the ion getter pump is taken as measure for vacuum pressure.

In addition there was the counter-intuitive observation, that when the gas injection into the source was stopped or the source was separated from the LEBT by closing a valve, the current/pressure in the ion getter pumps near to the source went up.

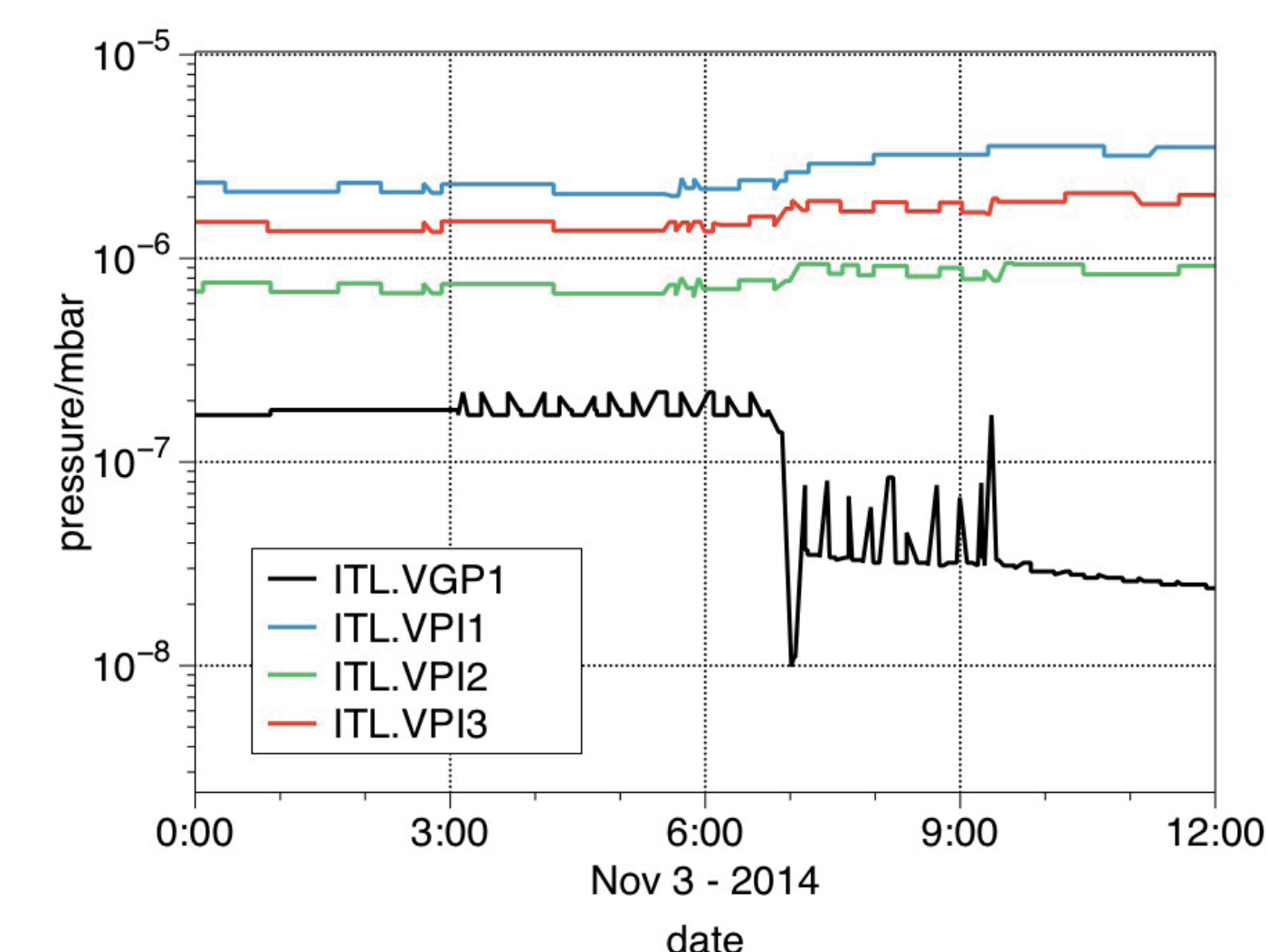

Vacuum measured in the LEBT with a Penning gauge (ITL.VGP) and in the ion getter pumps (ITL.VPI). At 7:00 the LEBT was separated from the source with a valve.

After the argon ion run the pumps recovered slowly (partially supported by baking). But the ion getter pumps directly after the source which have seen most of the argon had to be replaced.

Conclusions

The argon ion run in 2014/2015 was a very successful physics run. The injector chain could deliver over the whole period a stable argon ion beam of sufficient intensity.

But it was revealed as well that such a long term operation can be quite detrimental for parts of the source and the linac. Preventive maintenance is essential under such conditions. Eroded and metallized parts need to be replaced in time. The vacuum pumps need to be closely surveyed as the pressure in the machine is not the only indicator of the healthiness of the vacuum system.

All in all one can say that the performance in terms of beam properties may not always be the challenging part of the operation.

LEBT

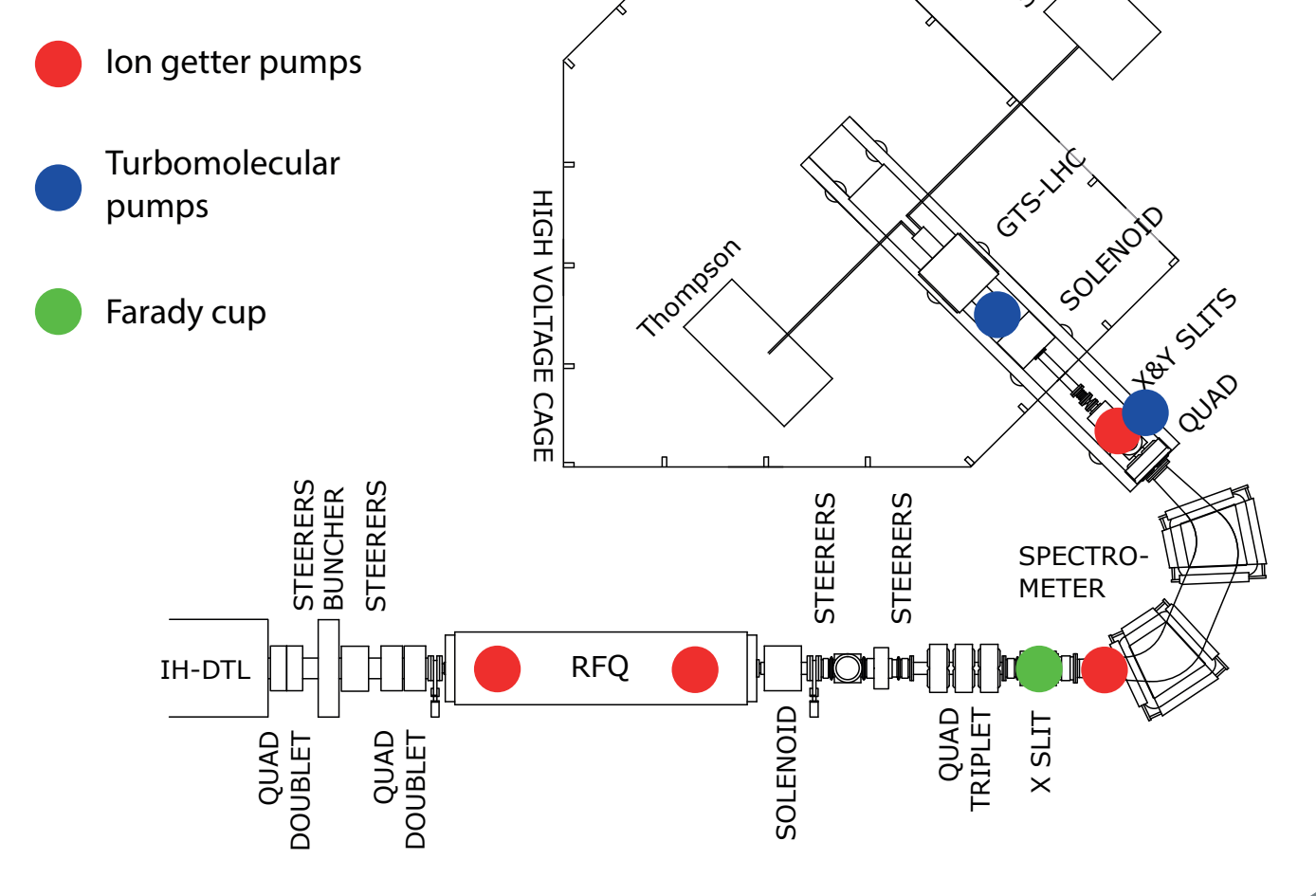

Contact information



Dr. Detlef Küchler
CERN
BE Department
CH-1211 Geneva 23
Switzerland
detlef.kuechler@cern.ch

