

MAGNETIC FIELD DESIGN FOR 2.45 GHz NEGATIVE HYDROGEN PMECRIS CHAMBER USING FEM SIMULATION

Chinmoy Mallick[†], Somesh V Tewari, Rajesh Kumar, Mainak Bandyopadhyay
 Institute for Plasma Research, HBNI, Gandhinagar-382428, Gujarat, India

Abstract

Negative hydrogen ECRIS plasma is confined by NdFeB permanent magnet antenna around cylindrical cavity wall. A combination of four axially magnetized ring magnets of remanence flux density of 1.17T is simulated using bounded current ampere's law technique. Gradient of radial and axial magnetic flux density is calculated to estimate the leaking out fraction of lighter ions from the plasma wall sheath region. Measured axial and radial magnetic fields are benchmarked with the simulated data. The peak values of radial magnetic field gradient between plasma sheath region and cavity outer wall surface increases from 0.1×10^7 A/m² to -0.2×10^7 A/m² respectively. Axial magnetic field gradient along inner ECR chamber wall increases from -2.1×10^7 A/m² to 2.5×10^7 A/m². ECR contour dimensions of 0.0875 T which corresponds to microwave plasma, having resonating frequency of 2.45 GHz. The thickness of resonating surface is ~1 mm and having major and minor radius of 30 mm and 28 mm respectively.

INTRODUCTION

Gaseous plasma has a significant role in the fabrication of semiconductor chips and sputtering purposes. Since last few decades, rigorous research work has been carried out in generation of capacitive and inductively coupled plasma for these industrial applications. Negative ion beam is being extensively used in accelerator and fusion related applications. Microwave ECR plasma is also important for these applications but one limitation is when large substrate are used but for smaller substrate it is an excellent technique. Low pressure (in the range of 10^{-3} mbar) microwave ECR plasma is very useful in the removal of impure material from semiconductor materials. Negative ion plasma demand is increasing in the reduction of air pollution [1]. Low pressure microwave plasma under ECR conditions can produce beams having high etching rates which are crucial for semiconductor fabrication technology [2, 3, and 4].

Permanent magnet ECR ion source (PMECRIS) will use microwave power of 500W at frequency 2.45 GHz to produce primary hydrogen plasma inside the source, which will further be optimized to generate negative hydrogen ions through surface conversion technique using cesium catalyst. Design optimization of ion source taking into account of minimum-B magnetic field configuration, microwave E-field launching and effects of Doppler

Broadening on resonance is demonstrated. This compact four ring magnet based ECR ion source is easy to

handle because it eliminates all the high voltage active components as is required in solenoid based electromagnets. The only system component that crosses the high voltage boundary is the microwave waveguide section and gas feed section, all other components are at high voltage situations. PMECRIS system can produce high charge state ion beams which has wide applications ranges from nuclear physics research to the material processing [3 and 4]. Four permanent magnet based ECR ion source is designed to construct a compact linear RFQ accelerator for research purposes. Magnetic field design is important for the expected performance of the ECR ion source system.

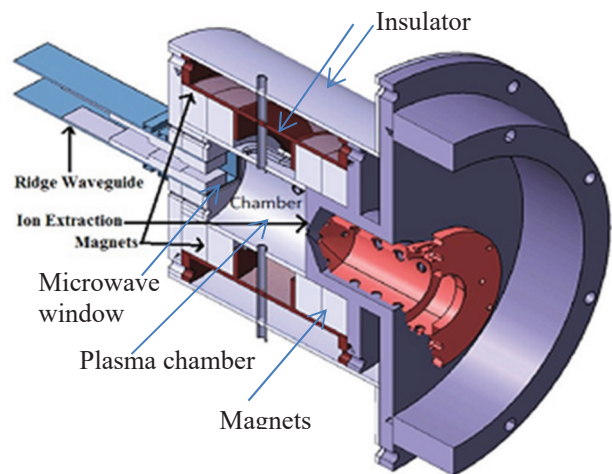

Figure 1: Section cut-view of negative PMECRIS.

MAGNETOSTATICS THEORY

This 2D axis symmetric model describes the magnetic field distribution inside the plasma chamber in cylindrical coordinates (Using azimuthal symmetry). The magnetic field of the NdFeB ring magnets is obtained from Ampere's law (bounded current) technique by the use of magnetic vector potential A which has only azimuthal non zero component [5]. The rare earth ring magnets are defined as two surface currents at inner and outer radial surfaces directed azimuthally in the opposite direction to each other. In this 2D axis-symmetric model, because of no variation of magnetic flux density at each point in the azimuthal direction, there exist only azimuthal component of the magnetic vector potential [5 and 6]. This is justified analytically as well as with simulation results. Axial component of magnetic field is given as $B_z = \frac{1}{r} \frac{\partial(rA_\theta)}{\partial r}$ and radial component of magnetic field calculated as $B_r = -\frac{\partial A_\theta}{\partial z}$

[†]chinmoy.mallick@ipr.res.in

Where $B = \mu_0 \mu_r H + B_r$. From Ampere Law curl of magnetic field after some calculations is given as follows [5 and 7].

$$\nabla \times (\mu_0^{-1} \mu_r^{-1} (B - B_r)) = \mu_0^{-1} \mu_r^{-1} \left[\frac{A_\theta}{r^2} - \frac{\partial A_\theta}{\partial r^2} - \frac{1}{r} \frac{\partial A_\theta}{\partial r} - \frac{\partial^2 A_\theta}{\partial z^2} \right] = J_e \quad \dots \dots \dots (1)$$

Here, J_e is external current density which comes from bounded surface currents on magnets, r , θ and z are radial, azimuthal and axial coordinates respectively.

DESIGN OF PMECRIS MAGNETIC FIELD CONFIGURATION

The compact negative hydrogen PMECRIS is ring permanent magnet sources in which axial and radial mirror field is created by four axially magnetized NdFeB(Grade N48) magnets having dimensions of length=30 mm, ID=100 mm and OD=180 mm. The plasma chamber made of copper has diameter of 86 mm and length of 109 mm is inserted into the magnetic structure.

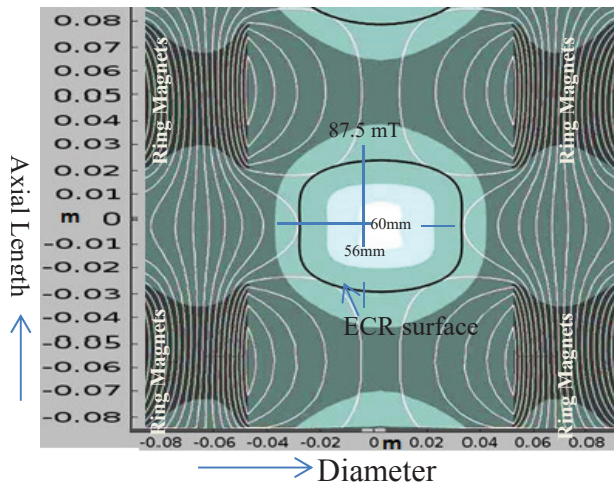

Figure 2: Magnetic field configuration of the inside chamber (Mirror 2D taken of computational domain) showing the ECR resonance surface (87.5mT, thick black line). ECR zone is around that dark line. White line represents the magnetic vector potential (A_ϕ) lines (Web/m). Surface intensities inside the source indicate the normalized magnetic flux density in the log scale ($\log_{10}(B_{normalized})$).

The plasma chamber is closed by a plasma electrode having an extraction hole of 5 mm and other side is closed by a boron nitride plate with a thickness of 6.4 mm. The volume of ECR zone is very small as compared to the whole volume of the plasma chamber. The ECR contour has major diameter 60 mm and minor diameter 56 mm and a thickness approximately 1 mm. In FEM model, infinite element domain is chosen as boundary condition as if magnetic vector potential lines are perfectly absorbed at the boundary and there is no interference of external magnetic field other than the magnet sources.

Inherent remanence flux density of each magnet 1.17T is oriented axially (z-direction) during modeling.

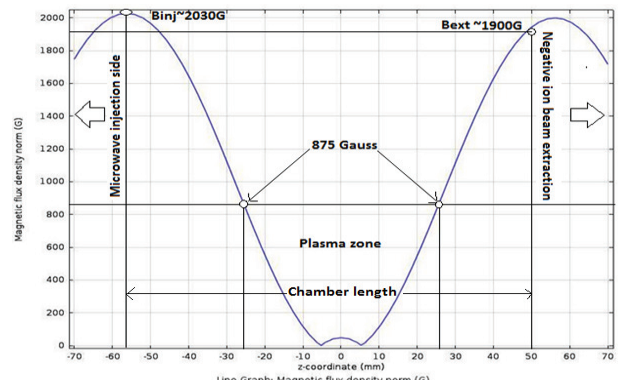

Figure 3: Axial B-field (simulation).

Because of the azimuthal symmetry B_z , B_r and A_θ are decoupled from the A_z , A_r , B_θ components and more interestingly the latter three terms are zero. The magnetic field at the microwave injection side is 0.203 T which is more than two times than the resonant magnetic field so that microwave travel downstream the magnetic field intensity and deposit power exactly on the ECR surface (0.0875 T). The magnetic field at the plasma electrode aperture is 0.19 T which should be somehow less (near to 0.0875 T) for the efficient ion extraction. But to get maximum microwave E-field at 2.4 GHz frequency in the plasma chamber, length of chamber limits plasma electrode position.

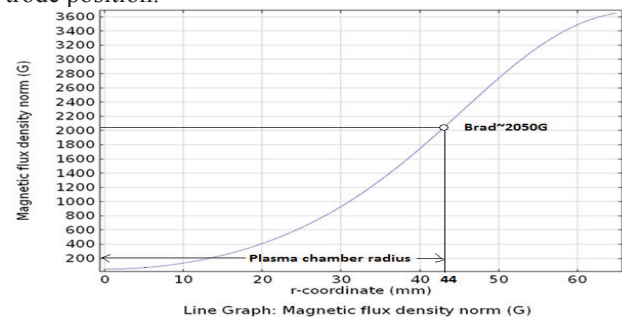

Figure 4: Radial B-field (simulation).

Radial magnetic field along the center of the plasma chamber is 0.205T(Fig.4) at the wall which is also two times more than the resonant magnetic field required to prevent the radial loss of ions.

B-Field Gradient: Resonance Characteristics

The location, flatness and dimension of the ECR zone is dependent on the magnetic field distribution inside the chamber corresponding to the frequency, microwave launching direction and also the type of mode in which the wave is propagating into the plasma. For microwave resonance heating in ECR zone electron energy distribution function exhibits a high energy peak. For which ECR zone gets shifted according to the relation [2], known as Doppler shift.

$$\omega_{rf} \pm k(z)v_{res\parallel} = \omega_{ECR}(z) = \frac{B_{ECR}e}{m_e} \dots\dots\dots(2)$$

$v_{res\parallel}$ is parallel component of electron velocity in resonance position, $k(z)$ relative dielectric constant. So here for 3 eV peak electron temperature $v_{res} \sim 10^6$ m/s [2 and 5] and $k=0.514$ cm⁻¹. As a result of Doppler shift, the corresponding resonant magnetic field gets higher or lowered. At the new position, electrons see different magnetic field gradient values parallel to magnetic field lines. Hence the resonance size is expanded by ± 1.4 mm and the resonant frequency is shifted by 2.5168-2.38 GHz. (0.0899-0.0715 T). For higher shifted resonant magnetic field (0.0899 T), gradient becomes lower (1.4×10^7 A/m²) considering the following relation [2].

$$\omega_{ce}(z') = \omega(1 + \alpha z'), \text{ Where } z' = z - z_{res} \text{ and } \alpha = \frac{1}{\omega_{ce}} \left(\frac{\partial \omega_{ce}}{\partial z'} \right)_{res}$$

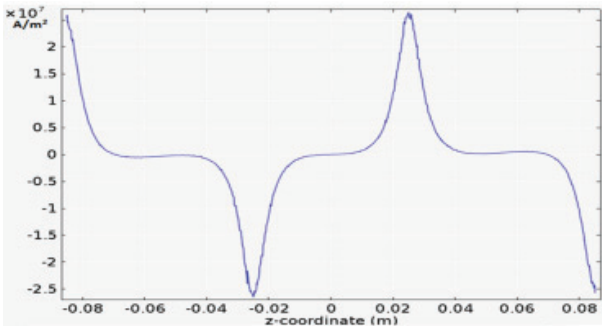

Figure 5: Magnetic Field Gradient parallel to microwave field line variations along z-axis of plasma chamber.

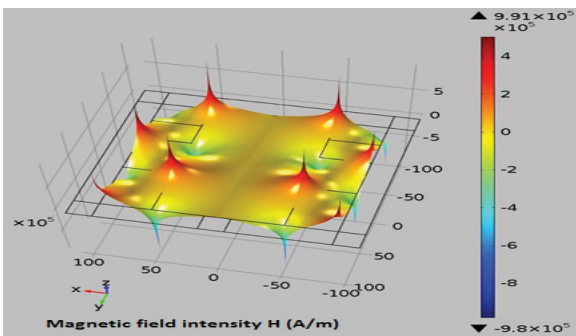

Figure 6: Total magnetic field gradient plot of the whole computational domain. (Mirror 2D taken of the half section of computational domain).

EXPERIMENTAL VALIDATION FOR B-FIELD

Two NdFeB based permanent ring magnets are used to generate the required magnetic field to create ECR zone inside the source volume. Each ring magnet is having OD=100 mm, ID=50 mm and thickness=10 mm. The axial spacing between two magnets was varied to get required field of 0.0875 Tesla. Field optimization has been carried out through simulation using the *B_M Field* code. The required magnetic field profile is obtained at a spacing of 25mm between the two magnets. The axial and

radial magnetic field is measured with the help of a Gauss meter (Lakeshore, Model 410), as shown in Fig. 7.

Axial simulated B-field (Fig. 8) is compared with the measured data. In *B_M Field* code simulation the magnetization value of each ring magnet was taken 8850. Axial and radial simulation results (Fig. 9) were taken always along the centre of the two magnets. Radially measured and simulated data were also taken along the centre of both the magnets.

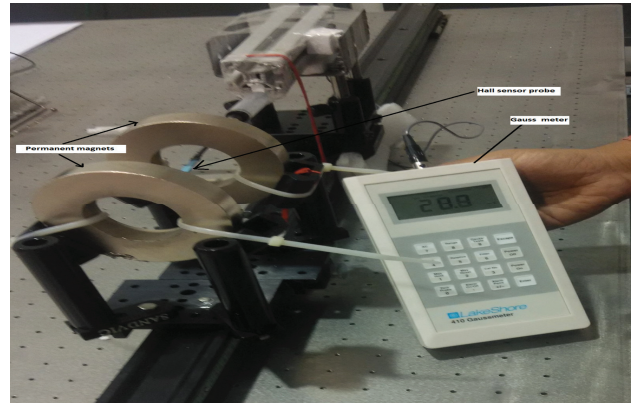

Figure 7: Experimental set up.

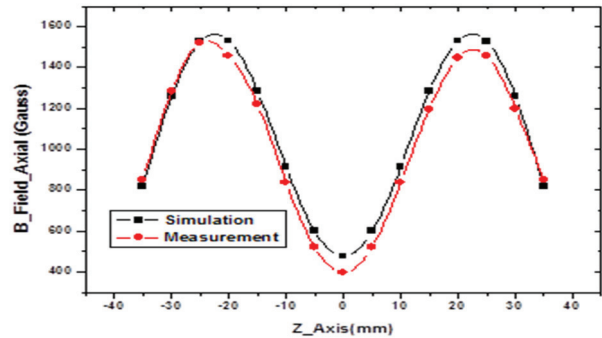

Figure 8: Axial measured and simulated B-field.

Finally, measured axial and radial field was benchmarked with *B_M Field* code [6] and FEM model [7, 8 and 9] for NdFeB, GradeN48 four ring magnets simulation.

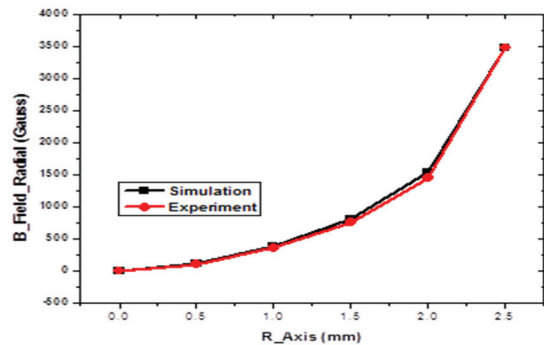

Figure 9: Radial measured and simulated B-field.

SUMMARY

Doppler shifted resonant zone depends on direction of electron's velocity w.r.t microwave propagation direction. Doppler effect broadens the resonance zone into regions of higher or lower magnetic field. Doppler broadening aids the power absorption capacity of plasma electron. Absorbed power depends on electric field, ECR surface area and more importantly on magnetic field gradient. Lower the gradient-higher the power absorbed by plasma. For shifted resonant field (0.0899 T) power absorption capability increased by 1.4 times.

REFERENCES

- [1] Jianxiong Dai, Zhongjun Zhao, Gaoling Liang and Yixiang Duan, 'A Novel Microwave-Induced Plasma Ionization Source for Ion Mobility Spectrometry', Scientific Reports 44051(2017).
- [2] M.A. Liberman, Allan J. Lichtenberg "Principles of plasma discharges and materials processing", John Wiley and Sons, New York, 1994.
- [3] Nasser, "Fundamentals of Gaseous Ionization and Plasma Electronics", John Wiley & Sons, 1971.
- [4] Chapman, "Glow Discharge Processes", John Wiley & Sons, 1980.
- [5] G J M Hagelaar, K Makasheva, L Garrigues, J-P Boeuf, "J.Phys D:Appl. Phys. 42(194019),(2009).
- [6] Donald Arnush., Phys. Plasmas 7, (3042) (2000).
- [7] www.comsol.com .
- [8] M. El Bojaddaini, H. Chatei, M. Atounti, M. El-Haim, I. Driouch and M. El Hammouti, Adv. Studies Theor. Phys., 7(22), 1071 – 1085 (2013).
- [9] J.Y.Park, H. S. Lee, M. S. Won, B. S. Lee, J. P. Kim, J. H. Yoon, J. S. Bae, J. K. Bang, J.K.Ahn., Journal of the Korean Physical Society 55(2), 409-414 (2009).