

# REVIEW OF EXPERIENCE WITH HOM DAMPED CAVITIES

H. Padamsee, Laboratory of Nuclear Studies, Cornell University, Ithaca, NY 14853, U.S.A

## Abstract

The RF systems for the next generation of high luminosity electron-positron and proton-proton colliders face new challenges. To achieve the desired luminosities, ampere beam currents need to be stored in a large number of bunches spaced together closely. The high current puts severe demands on the power capability of input couplers, windows and higher mode couplers. The large number of bunches and tight bunch spacing makes control of multibunch instabilities a critical issue. It becomes imperative to reduce the beam-cavity interaction by lowering both the  $R/Q$  and the  $Q$  of higher order modes (HOM). Even the fundamental accelerating mode can cause coupled bunch instabilities. Both superconducting (SC) and normal conducting (NC) cavity designs have been prepared to meet the combined challenges of high power and low impedance. The cavity developments are in their advanced stages of beam tests and initial operating experience. We will briefly review the various designs. Our emphasis will be on system performance, operating experience at high power and with beam.

## 1 INTRODUCTION

At previous conferences, J. Kirchgessner [1, 2], K. Akai [3] and R. Boni [4] reviewed the RF issues and parameters for high current storage rings. They also presented overviews of the design and status of the corresponding RF systems under development.

Today CESR is the highest luminosity storage ring running at  $5.6 \times 10^{32} \text{ cm}^{-2} \text{ s}^{-1}$  with an upgrade in progress to double the luminosity. SLAC and KEK are currently commissioning new B-factory storage rings, PEP-II and KEKB, to aim for luminosities in the range of  $10^{33} \text{ cm}^{-2} \text{ s}^{-1}$  to  $10^{34} \text{ cm}^{-2} \text{ s}^{-1}$ . Also being commissioned is the  $\Phi$ -Factory, DAFNE, aiming for a luminosity of  $5 \times 10^{32} \text{ cm}^{-2} \text{ s}^{-1}$ . At CERN, a proton-proton collider is under construction shooting for a luminosity of  $10^{34} \text{ cm}^{-2} \text{ s}^{-1}$ .

In the TRISTAN/HERA/LEP generation of storage rings the typical beam currents are in the 10 – 100 mA range. For the upcoming generation of high luminosity machines the beam currents will be in the ampere range. Both SC and NC cavities have been upgraded in key aspects to make them suitable for such high current. The cavities are made single-cell so that the input power per coupler can be kept below 500 kW, and so that HOMs can be strongly damped.

## 2 NC/SC TRADE-OFFS

Table 1 summarizes the performance expectations of the SC RF installations for CESR, KEKB-HER and LHC. Here  $V_c$  is the one-cavity voltage,  $I_b$  is beam current,  $P_b$  is beam

Table 1: Expected Performance from SC Cavities

Parameter	CESR	KEKB	LHC
No. of Cav.	4	8-10	16
Voltage (MV)	1.8	1.6-2	2
$I_b$ (A)	1.0	1.1	1.1
$P_b/\text{Cav}$ (kW)	325	250	32
$P_{HOM}/\text{Cav}$ (kW)	11	5	small

Table 2: Expected Performance from NC Cavities

Parameter	PEP-II	KEKB	DAFNE
No. of Cav.	6/20	16-22/12	1/1
$V_c$ (MV)	0.85/0.7	0.5/0.5	0.26/0.26
$I_b$ (A)	2.25/1.0	2.6/1.1	1.4/1.4-5
$P_b/\text{Cav}$ (kW)	308/187	250/250	30/30
$P_{tot}/\text{Cav}$ (kW)	413/256	375/340	50/50
$P_{HOM}/\text{Cav}$ (kW)	30/10	30/10	3

power delivered by one cavity,  $P_{HOM}$  is HOM power extracted from one cavity.

Since SC cavities can economically provide higher CW gradients than NC cavities, the necessary voltage can be provided by fewer cells, which means reduced overall impedance. In high current storage rings a high  $R/Q$  in the fundamental mode can also give rise to a multibunch instability. Another issue connected with the high  $R/Q$  of the fundamental mode is transient beam loading which can be strong for the LHC. The large beam pipe aperture of SC cavities results in a lower fundamental mode  $R/Q$ . Together with the higher stored energy associated with the higher voltage of SC cavities, the fundamental mode driven instability and transient effects are reduced. Table 2 summarizes the performance expectations from the NC cavity system installations for PEP-II, KEKB-HER, and DAFNE. Here  $P_{tot}$  is the copper wall dissipation plus beam power to be provided by one cavity.

In the case of PEP-II, the anticipated fundamental mode driven instability will be addressed with multiple level feedback loops around the klystron-cavity-beam system. In the KEK-B LER the fundamental mode driven instability would remain high even if either SC cavities or conventional NC cavities were to be envisioned. To keep the beam power delivered by a single cavity below 500 kW, the voltage per cell is low because the LER needs *both high beam current and low total voltage*. As a result, the stored energy is not high enough. Therefore a special normal conducting cavity, called ARES, has been developed with fundamental mode  $R/Q$  reduced to 15 Ohm. ARES stands for Accelerator

Table 3: Comparison of Geometries of SC Cavities

Parameter	CESR	KEKB	LHC
Fund. Freq (MHz)	500	509	400
Fund. R/Q (Ohm)	89	93	88
Max $\parallel$ R/Q ( $\Omega$ )	10	6.6	13
Max $\parallel$ R/Q*Q ( $\Omega$ )	250	700	3900
Max $\perp$ R/Q ( $\Omega$ )	25	15.3	89
Max $\perp$ R/Q*Q (k $\Omega$ )	5	1.7	18

Table 4: Comparison of Geometries of NC Cavities

Parameter	PEP-II	KEKB	DAFNE
Fund. Freq (MHz)	476	509	368
Fund. R/Q (Ohm)	232	15	122
Max $\parallel$ R/Q ( $\Omega$ )	80	22	32
Max $\parallel$ R/Q*Q (k $\Omega$ )	4.6	0.42	1.6
Max $\perp$ R/Q ( $\Omega$ )	56	21?	10.2
Max $\perp$ R/Q*Q (k $\Omega$ )	5.6	0.6	?

cavity Resonantly coupled with an Energy Storage cavity. The drastic reduction in fundamental mode impedance is achieved by coupling the accelerating cavity to a storage cell, which increases the stored energy of the accelerating mode. The present plan envisions the exclusive use of ARES cavities in the LER. Some ARES cavities will also be used in the HER resulting in a hybrid NC/SC RF system for the HER.

NC cavities have smaller beam holes compared to SC conducting cavities which means larger  $R/Q$  of HOMs. But the effectiveness of the HOM couplers in reducing the  $Q$  values is equally important, so that it is more meaningful to look at the  $R/Q * Q$ . Table 3 and Table 4 give the highest  $R/Q$  as well as the highest remaining  $R/Q * Q$  for the monopole and dipole modes. Note that in the LHC case the HOM  $R/Q$  values were measured for four coupled single cells. In all cases we use *two times* the URMEL definition of  $R/Q$  for monopole and dipole modes in ohms.

### 3 SUPERCONDUCTING VERSIONS

The upgrade of CESR is based on the SC cavity system shown in Fig. 1. Its characteristic features are a large beam pipe, ferrite lined beam pipe HOM loads, a high power waveguide input coupler and a planar ceramic waveguide window[5]. In acceptance tests, four cavities reached accelerating gradients of 12 MV/m, 10 MV/m, 11 MV/m and 7.2 MV/m.

Besides lowering the  $R/Q$  of the HOMs, another benefit is that the HOMs propagate out of the cell to the HOM loads located outside the cryostat. By lining a short section of the warm beam pipe with ferrite, the HOM  $Q$  values are reduced to near or below 100. Many kilowatts of beam-induced HOM power can be safely dissipated in these absorbers. Ferrite-lined beam pipe couplers have been tested to 7 kW

in vacuum and higher powers in air. These beam pipe HOM couplers are a significant advance over the loop- and antenna-type couplers used in the present generation storage ring SC cavities. The latter type lower HOM  $Q$  values of  $10^3$  to  $10^4$  and handle a few hundred watts of beam-induced HOM power and need sophisticated resonant filter circuits integrated with the coupler design to reject the fundamental.

Four planar waveguide windows, designed and manufactured by Thomson Tubes have been high power tested[6]. The windows were coated with Ti on the vacuum side. In the travelling wave (TW) mode the best reached 450 kW CW and 520 kW at 25 % duty factor. In the standing wave (SW) mode (full reflected power) they were tested to 125 kW at all phases with 50 % duty factor. ‘‘Tickle processing’’ [7] with 30% superimposed pulses was used to limit the gas load and prevent frequent tripping to condition the window in a few days. The pressure limit during window conditioning was held below  $10^{-7}$  torr. After assembling the cavity and components with the beam line cryostat a high power test was carried out with about 150 kW reflected power. After this the cavity was installed.

Fig. 2 shows the KEKB SC cavity cryostat with coaxial high power input coupler and ferrite beam pipe HOM loads[8]. Fig. 3 shows the KEK SC niobium cavity for the HER of KEKB. Four cavities for the HER have been delivered and acceptance tested. The gradients reached were 10.3, 11.9, 12.9 and 18.7 MV/m. The coaxial windows and input couplers were high power tested to 850 kW in TW and 300 kW in SW. The HOM dampers were tested up to 15 kW in air. After assembling the cavity and its components in the beam line cryostat a high power test is carried out to about 300 kW reflected power. The first assembly has been tested in this configuration to 12.3 MV/m,  $V_{acc} = 3$  MV. At  $V_{acc} = 2.5$  MV, the  $Q_0$  was  $1.9 \times 10^9$ .

Because of the long bunch length in the LHC, the HOM damping and beam induced power are not as severe as for the high current electron machines. The designs for LEP-type HOM couplers are deemed to be adequate. The demand of the input coupler is also in the range of LEP technology.

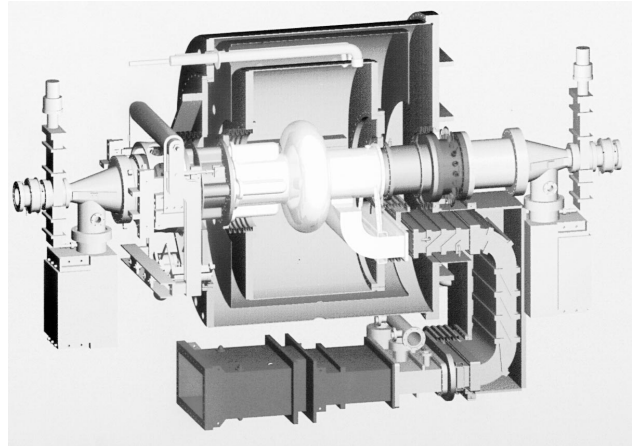

Figure 1: SC cavity for CESR-III in cryostat.

Prototype superconducting cavities have been successfully tested at high current in CESR (August 1994), in the Accumulation Ring (AR) at KEK (March - November 1996) and in the SPS. During both the CESR and KEK prototype beam tests, numerous beam stability studies were conducted for a variety of bunch configurations. No beam instabilities or resonant excitation of HOMs was observed. These tests confirmed that all HOMs are damped sufficiently to render them harmless.

In the first part of the beam test at the KEK, due to poor vacuum conditions in the AR, there were frequent trips attributed to discharge caused by condensed gas on the cold surfaces of the input coupler. After improving the pumping and warming up the cavity the problem disappeared.

A prototype superconducting cavity has already been fabricated, tested, and installed in the SPS. It was also based on the LEP technology of sputtered niobium on copper. The cavity operated at a gradient of 3 MV/m with the usual current for the SPS, which is  $\approx 50$  mA average.

The first SRF system for long-term operation was installed in CESR during September '97 in the place of one of the 5-cell NC systems. It gets 40% of the 500 kW klystron power sharing the rest with the 5-cell NC cavity. The SC cavity has been operating well for eight months and has accumulated nearly 1000 Amp hours of operation. The routine operating gradient is 6 MV/m and the voltage provided is 1.8 MV. The maximum gradient tolerated by the cavity for CW operation is 9 MV/m. The typical total beam current is between 300 – 400 mA and the maximum to date for CESR is 460 mA. The maximum beam power delivered to the beam is 180 kW, the present world record with SC cavities. The maximum beam induced HOM power extracted is about 4.5 kW. Colliding beam operation and HEP runs have been proceeding normally.

To increase the beam power delivered it was found helpful to process without beam and with increasing power in the *pulsed mode* both on and off resonance, as well as near the cavity resonance. Because the SC cavity is heavily overcoupled without beam, the emitted power at RF shut-off is four times the input power. This helps to pulse process

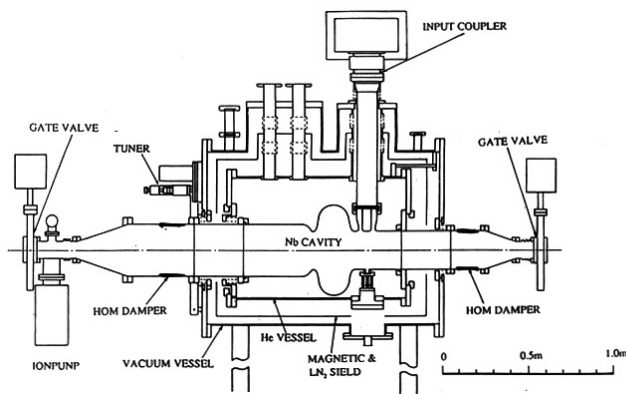

Figure 2: Superconducting RF System for KEKB HER.

in the TW mode, but for a very short time. Changing the frequency around resonance shifts the standing wave pattern in the input line, and processes different regions of the input line in the standing wave (SW). Above 80 kW forward power, the cavity quenches and becomes a matched load allowing longer time processing at resonance in the TW mode — closest to type of processing needed when beam is present.

After the first cool down, the beam power delivered was limited below 100 kW in the CW TW mode due to gas evolution in the input coupler/window region. By pulse processing (as described above) to 150 kW, the beam power could gradually be raised to 140 kW. At this level there would be frequent fast trips, attributed to discharge somewhere in the input coupler region. There was also a deterioration to 130 kW.

After warming up the cavity to room temperature and baking the window in situ to 110 °C during a scheduled CESR shut down, the beam power delivered began to rise steadily. The fast (arc) trips were markedly reduced. Pulse power processing could proceed to 200 kW. It was also possible to slowly process in the presence of beam. The maximum beam power delivered at 7 MV/m is now 180 kW. At this stage, the forward power needed for the NC and SC cavity pair is close to the maximum power (500 kW) out of the klystron.

As we mentioned, during the AR beam test of the prototype KEK SC cavity a similar improvement in processing was observed due to cavity warm up. Therefore condensed gases in the input coupler region could be playing a role for both CESR and AR cases.

Table 5 summarizes the performance of SC cavity systems in high current storage rings. Also included are some results of the CESR prototype test in '94.

#### 4 NORMAL CONDUCTING VERSIONS

Twenty NC cavities have been installed in the HER and four cavities installed in the LER of PEP-II[9]. Each cavity assembly (Fig. 4) is installed along a raft with the window, coupler, tuner and HOM loads. The nose-cone shaped cell is equipped with three waveguide HOM couplers to provide heavy damping. The HOM load terminations are

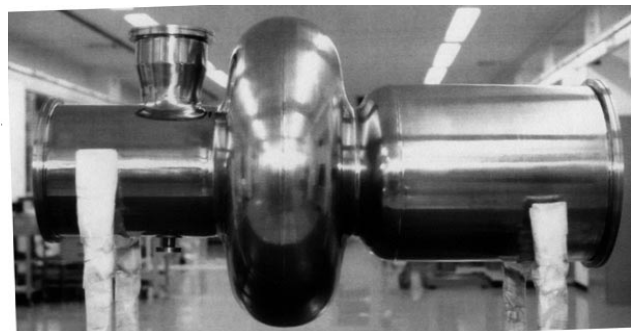

Figure 3: Superconducting niobium cavity for KEKB HER.

Table 5: Performance of SC Cavity Systems in Beam

Parameter	CESR 94	CESR 97	KEK
$V_c$ (MV)	1.5-1.8	1.8-2.3	1.2-2.5
$I_b$ (A)	0.22	0.46	0.57
$I_b T$ (Ah)	20	1000	200
$P_b/Cav$ (kW)	155	180	160
$P_{HOM}/Cav$ (kW)	2	4.5	4.2

made from AlN with SiC as the lossy material. The alumina windows are coated with  $6 \times 10^{15}$  atoms  $\text{cm}^{-2}$  of TiN that is thinner at the center of the window and thicker at the edges. This distribution is found to be optimum for reduced multipacting as well as reduced overall ceramic heating. Baking the windows at  $150^\circ\text{C}$  was found more helpful than  $135 - 140^\circ\text{C}$  presumably due to more complete removal of gases from the surface of the ceramic. Under these conditions, which were determined after some R&D, the temperature rise at the center is about  $30^\circ\text{C}$  during the high power commissioning of windows to 500 kW into a matched load. Typical best window processing times are of the order of one day.

The cavity assembly is carried out in a class 100 clean room after which the cavity is vacuum baked to  $150^\circ\text{C}$ . The cavities and associated components are conditioned to 0.8 MV at 86 kW wall dissipation and 0.86 MV, 103 kW wall dissipation for LER operation. During high power commissioning of the cavities, the vacuum interlock is set at  $5 \times 10^{-7}$  torr during low power FM processing and reduced to  $10^{-8}$  torr for the high power processing above 40 kW. The RF is tripped off within  $15 \mu\text{s}$  by light detectors. The temperature rise of the window ceramic is  $17 - 24^\circ\text{C}$  for HER power levels.

Fig. 5 shows the HER cavity string installed in the PEP tunnel. The HER cavities have been operated at  $0.8 - 0.85$  MV and  $86 - 97$  kW wall dissipation which gave a maximum cavity surface temperature of  $75 - 80^\circ\text{C}$ . The typical operating powers are 160 kW forward and 60 kW reflected. The highest current stored was 750 mA during which the cavities were running at 0.63 MV with 50 kW dissipated in the cell and 135 kW delivered to the beam and

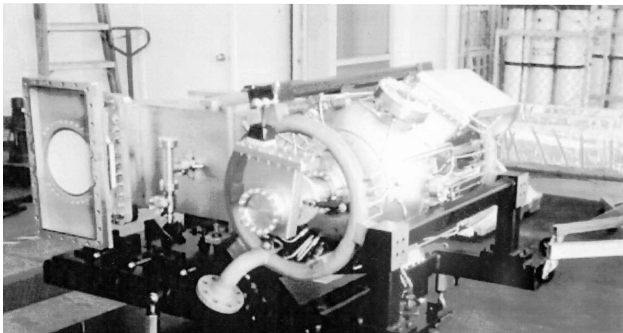

Figure 4: Normal conducting cavity for PEP-II.

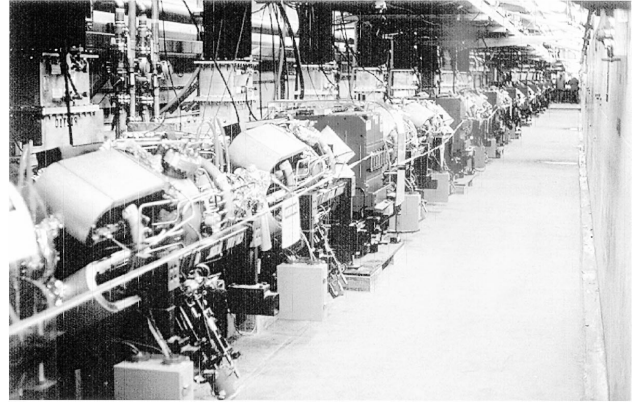

Figure 5: RF installation in the HER of PEP-II.

2 kW of extracted HOM power.

The special ARES cavity is shown in Fig. 6 and Fig. 7. It is composed of three cavities: the accelerating cavity, the coupling cavity and the storage cavity. The energy storage cavity is a large cylinder (about one meter in diameter and one meter in length) operating in the  $TE_{013}$  mode. The accelerating cavity has grooved beam pipes to couple out the dipole modes. HOM power is absorbed by SiC bullet shaped absorbers. The accelerating mode has no field excitation in the coupling cavity. Therefore both parasitic modes in the accelerating pass band can be selectively damped with a coaxial antenna coupler in the coupling cavity. The residual impedance from these two modes tend to cancel out because they are located symmetrically about the accelerating mode. Fixed tuners adjust the frequencies of these modes as needed. The 0 and  $\pi$  modes of the coupling cavity are damped to  $Q$  values of about 100 with a coupling cavity damper to dissipate a few kW in the LER. The damper is placed outside a coaxial alumina disk window. A choke filter blocks the accelerating  $\pi/2$  mode. The coupling cavity acts as a filter to isolate the storage cavity from the HOMs of the accelerating cavity. The ARES cavity has been high power tested off-line to a maximum 0.76 MV at 250 kW wall dissipation. The input coupler/window has been tested to 850 kW. The ARES cavity was beam tested in the AR at KEK to a maximum current of 500 mA. The cavity voltage during operation was 0.5 MV. The maximum beam power delivered was 74 kW and the maximum HOM power extracted was 6.4 kW. No beam instabilities due to the impedance of the ARES cavity was observed.

Fig. 8 shows a single cell NC cavity installed in DAFNE. The cavity cell has a rounded shape with nose cones and is made from a single copper billet. It is connected to the beam pipe with long tapered beam tubes and loaded with three rectangular waveguides to damp the HOMs. Two additional damping waveguides are connected on the tapers. The waveguides are converted to coax by means of a smooth broadband double ridge transition. The extracted HOM power is dissipated in a coaxial load tested to 4 kW. The input power coupler is a waveguide to coax transition, followed by cylindrical ceramic window and ter-

Table 6: Performance of NC Cavity Systems

Parameter	PEP-II	ARES	DAFNE
Voltage (MV)	0.8	0.5	0.25
$I_b$ (A)	0.75	0.5	0.07
$I_b$ Time (Ah)	50	150	5
$P_b/Cav$ (kW)	135	74	small
$P_{diss}/Cav$ (kW)	86-97	155	17
$P_{HOM}/Cav$ (kW)	2	6.4	small

minated by rotating loop. In DAFNE, the total current so far is 70 mA for positrons and 50 mA for electrons in single bunches. The cavity was operated at 0.25 MV with 17 kW wall dissipation.

Table 6 compares the beam performance of the NC systems installed.

## 5 CONCLUSION

Over the last five years several designs for high power NC and SC cavities have been developed for the upcoming generation of high current accelerators in the ampere beam class. The cavities, couplers and their associated systems have been built, prototype versions high power tested and beam tested. Installation and commissioning of several systems has begun. So far the performance looks promising for meeting the hoped-for expectations. Yet the final word for any of the designs is not in because their performance is inextricably linked with reaching the high currents. At the same time the ability to reach high currents depends as much on the performance of the cavities.

## 6 ACKNOWLEDGEMENTS

I am indebted to R. Rimmer from SLAC, R. Boni from INFN, K. Akai and T. Furuya from KEK, and V. Rodel from CERN, for vital information on operations as well to S. Belomesnykh, E. Chojnacki, J. Knobloch and T. Hays from Cornell for help in preparing this review.

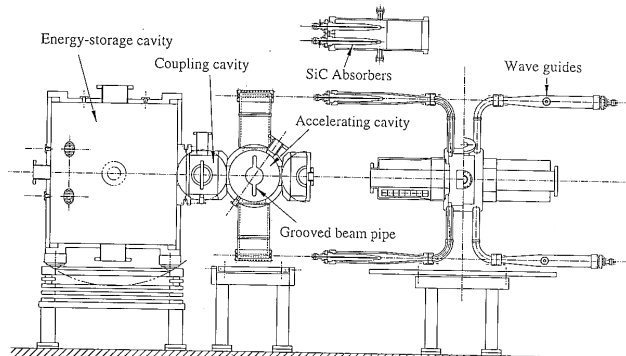

Figure 6: A schematic of the ARES cavity for KEKB.

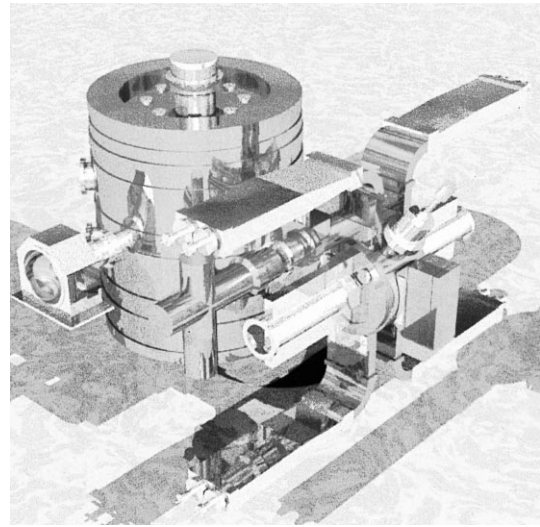

Figure 7: The ARES cavity for KEKB.

## 7 REFERENCES

- [1] J. Kirchgessner, in *Proc. of the 1995 Particle Accelerator Conference*, Dallas, TX, p. 1469 (1996). Cat. No. 95CH35843.
- [2] J. Kirchgessner, *Part. Accel.*, **46**(1):151 (1995).
- [3] K. Akai, in *Proc. of the 5th European Particle Accelerator Conference*, ed. S. Myers et al., p. 205 (1996).
- [4] R. Boni, in Reference 3, p. 182 (1996).
- [5] S. Belomesnykh et al., in *Proc. of the 1997 Particle Accelerator Conference* (1997). To be published.
- [6] E. Chojnacki et al., in Reference 5.
- [7] E. Chojnacki, Cornell, private communication.
- [8] Y. Funakoshi and K. Akai, in Reference 5.
- [9] R. Rimmer, in Reference 3, p. 2032 (1996).

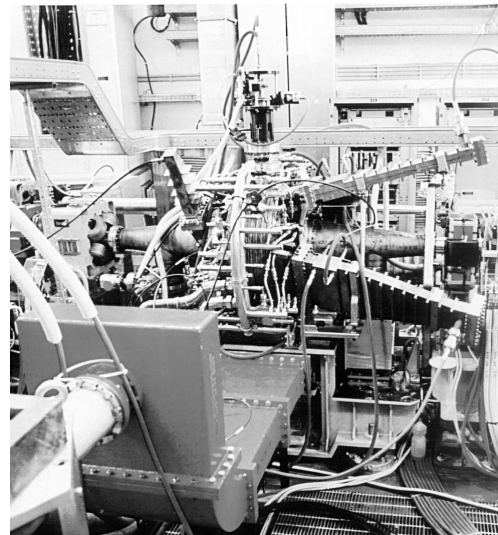

Figure 8: DAFNE RF installation.