

# PORTABLE LINAC USING CW MAGNETRON AS POWER SOURCE

L.Begin, E.Black, H.Deruyter, B.Green, A.V.Mishin, T.Roumbanis, R.G.Schonberg, D.Skowbo, K.Voak, R.Wurster, - Schonberg Research Corporation , R.Foose, W.Sapp – AS&E, R.Miller, D.Yeremian - Stanford Linear Accelerator Center, Y.Batygin - RIKEN.

## Abstract

This paper is devoted to the design and initial experimental testing of a high power linear accelerator (linac) for various commercial applications, such as sterilization of medical products, electron beam curing, non-destructive testing and other commercial and scientific applications which require high power electron beams. The main difficulty for use of a CW source for room-temperature linac operation is that the peak power is fairly low, which results in low accelerating field in the linac microwave structure. This makes it difficult and in some cases impossible to bunch and accelerate particles in the low velocity region. Extensive research in this field has shown that it is possible to substantially improve linac operation in the region of low particle velocities (0.1c to 0.5c, c- speed of light) and even reduce the injection voltage to 6-18 kV, in the case of electrons. The proposed design of a 1 MeV, 10 mA machine supersedes the prototype characteristics [1]. The proposed patented design [2] makes it possible to meet the desired specification and to be capable of operating in either a CW mode or a long-pulse mode using a 30 kW magnetron or another microwave power source.

## 1 SYSTEM DESIGN

The block diagram of the proposed system is shown in Fig.1. The configuration of the system is similar to that for a conventional pulsed linac with several exceptions.

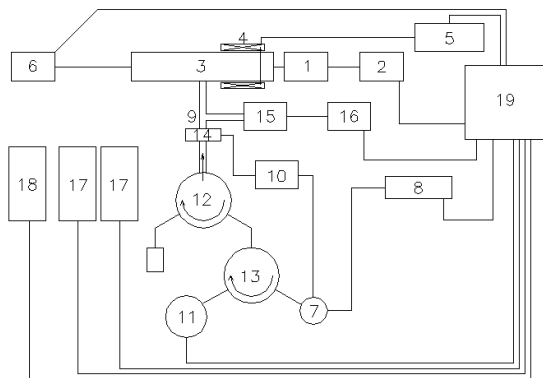

Figure 1: System block diagram.

Electron beam is formed in the electron gun manufactured by Litton Industries (1). High voltage power supply (2) provides 0 to 20 kV to the e-gun accelerating gap. From the electron gun, the electron beam is injected into a 1.3 m long linac section (3), where it is accelerated to the designed energy of 1 MeV. A magnetic system consists of sets of steering coils and three short solenoids (4). Each

solenoid is powered by a separate Sorenson power supply (5) providing adjustable magnetic field up to 450 G peak. The accelerated beam strikes the tungsten target (6) producing X-rays. For users interested in electron beam applications, an electron beam window with a scanning magnet can be installed at the accelerator output. A 30 kW magnetron operating at 2450 MHz is used as the RF source (7). Spellman power supply (8) is used to operate the magnetron. The same power supply drives the magnetron electromagnet. CW microwave power is transported through the waveguide WR430 (9). Magnetron “dome” window and the anode are air-cooled by the fans (10). Magnetron frequency is locked using a 0 to 1 kW RF signal generated by a Varian klystron with power supply (11). The phase-locking signal is injected into the magnetron through a RF circulator (13). Second RF circulator (12) isolates magnetron from the accelerator section. RF window (14) seals off linac vacuum envelope. The latter includes a compact vacuum ion (VI) pump (15) activated by a VI power supply (16). Targets, linac, magnetron and other components subject to intensive heat dissipation are water-cooled using two temperature regulated water circulators designed for 35 kW each (17). Water flow meters are installed on the water distribution panel (18). Using of two separate water circulators also helps to stabilize the system operation and adjust the accelerator guide and magnetron resonant frequency. The control console (19) is used to drive and control the parameters of the system.

The first prototype of the accelerator was developed as an X-ray source for truck inspection under a contract with American Science and Engineering<sup>1</sup>. The 1 MeV accelerator is designed to upgrade the existing “flying spot” system [3] currently using a DC tube at 450 kV. The assembly drawing which shows the linac position with respect to the “flying spot” wheel support is shown in Fig.2.

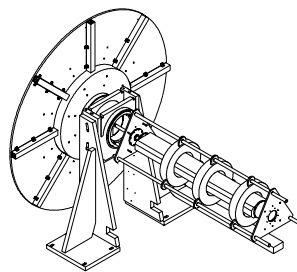

Fig.2 Linac incorporated into AS&E system

<sup>1</sup> Information is released with permission of AS&E

It represents the integration of the proposed linac with the AS&E system. Other components such as magnetron, circulator, etc. have not been shown in order not to overload the drawing.

## 2 COMPONENTS DESIGN

### 2.1 Accelerator Guide

The original design of the accelerator guide is based on the concept of combining two different structures: Alvarez and on-axis or side-coupled structure [4,5,6].

Based on the patented design [2], a fairly short 1.3 m long accelerator guide shown on Fig.3 was built for an extremely low injection voltage of  $12 \pm 6$  kV. The linac design permits acceleration in a broad range of particle velocities from  $0.2c$  to  $1.0c$  at an average gradient of 1 MeV/m using power source of only 30 kW.

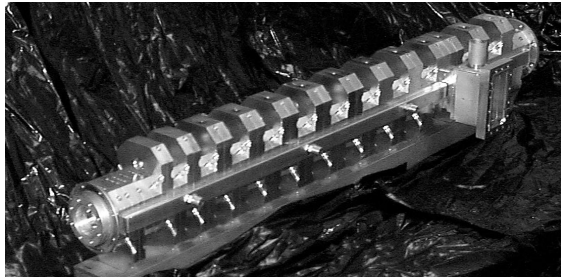

Figure 3: View of 1.3 m long accelerator guide.

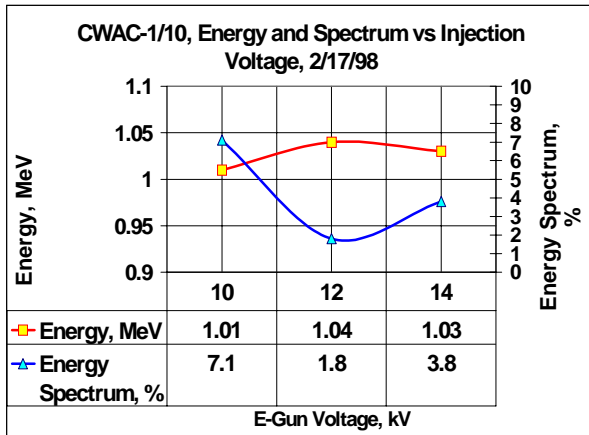
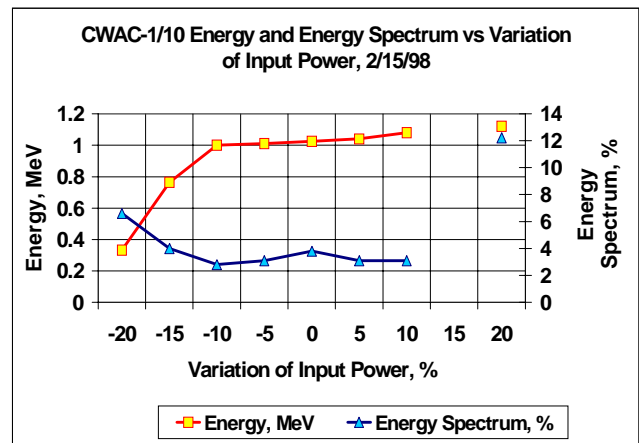

Figure 4: Calculated energy gain and energy spectrum versus input power.

Original calculations of beam dynamics and section geometry were made using a computer code AXIL. The preliminary results of these calculations were used for further more sophisticated beam dynamic simulation. The results of the computer simulation using codes Parmela and Beampath are shown in Fig.4 and 5. For the chosen



geometry, a moderate field of 300-400 G is required to transport the electron beam through the structure.

Figure 5: Calculated energy gain and energy spectrum versus input power.

The guide was tuned to the designed frequency of 2450 MHz. Separation of the neighboring resonances from the working resonance is approximately 2 MHz (Fig.6).

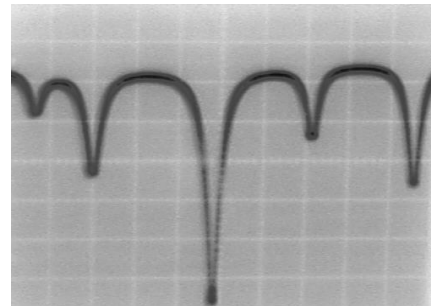

Figure 6: Main resonance at 2450 MHz (center) and neighboring resonances of the accelerator guide.

### 2.2 RF source and RF components

The 30 kW, S-band, CW magnetron CWM-30S manufactured by California Tube Laboratory [7] is used as a RF power source in the system .

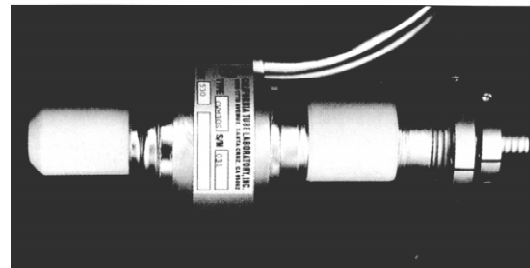

Figure 7: View of 30 kW CW magnetron

The magnetron has a broad output spectrum, which has been phase-locked using a klystron with 1 kW maximum output power [8] (Fig.8). Left peak in Fig.8 is a sample signal from a frequency synthesiser.

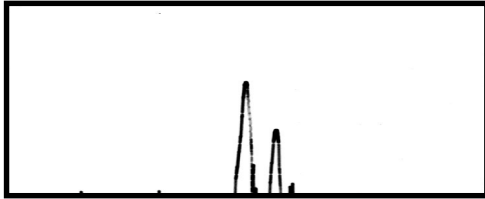

Fig.8 30 kW magnetron output (right) phase-locked by introducing a 500 W signal from klystron to magnetron input through a three-port circulator.

The klystron is built in a standard rack with the power supply. The phase-locking signal is forwarded to the magnetron input through a circulator. The same circulator is used to isolate the power sources from the accelerator guide. A detailed description of phase-locking and frequency tuning technique of the magnetron using an external power source will be published in the Proceedings of EPAC98 or elsewhere [9].

### 2.3 Power supplies and other elements

A Spellman MG48 power supply was recommended by California Tube Laboratory (CTL) to drive the magnetron. It also contains the power supplies for the magnetron filament and magnetron magnet. This power supply system is made up of four 12 kW inverter modules and a control module. This power supply system controls the RF output power by controlling the magnetron anode current. It provides an automatic filament current runback as magnetron anode current is increased. It also provides inputs for remote control of magnetron high voltage and current, magnet current, and filament current and outputs for monitoring these parameters.

To summarize the above, the system contains 6 main elements - three standard racks, two chillers, and accelerator beam centerline.

We expect that the selling price of the system will be substantially less than the price of similar pulsed systems.

## 3 HIGH POWER TESTING

The system has been tested at high power and currently is being processed to achieve maximum beam power. Energy measurements (Fig. 9) show that the system operates very close to a designed energy level. Beam power has been increased to at least one kW level.

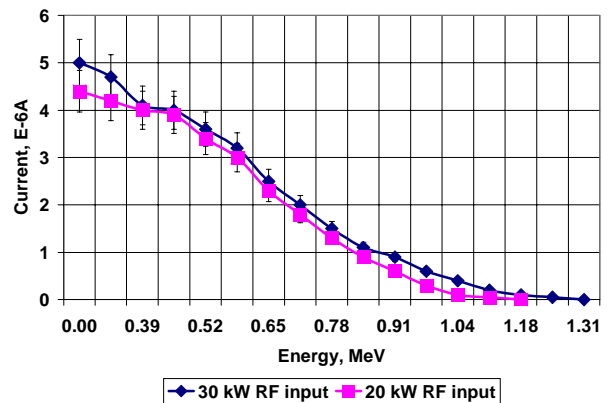

Fig.9 Experimental results of energy measurements obtained using a multi-plate Faraday Cup.

## 4 ACKNOWLEDGEMENTS

The authors would like to express gratitude to Dr. Bill Adams and Mr. Al Gladen, representatives of the customer, for their continuous attention and support. It is also hard to overestimate help of our consultants: Dr. Yuri Batygin, Dr. Diane Yeremian and Dr. Roger Miller.

The authors apologise that the information provided in this paper is very brief and will be happy to provide any details upon request. Please contact Dr. Andrey V. Mishin at [AMISHIN@COMPUSERVE.COM](mailto:AMISHIN@COMPUSERVE.COM).

## 5 REFERENCES

1. A.S.Alimov et al Compact Two Section CW Electron Linac With High Beam Power, Preprint INP MSU - 94 - 34/356, Moscow, 1994.
2. A.V.Mishin, R.G.Schonberg CW Particle Accelerator with Low Particle Injection Velocity, US Patent 5,744,919, 1998, priority 12/96.
3. American Science and Engineering Advertising Brochures.
4. A.V.Mishin, V.P.Komarov, Accelerating Structure for Charged Particle Linear Accelerator, Invention SU #1577678, 1990, priority 12/1988.
5. A.V.Mishin, Ph.D. Thesis, Moscow Engineering Physics Institute, Moscow, 1992.
6. A.V.Mishin Design and Application of Microwave Structure for Low Velocity Particles, Proc. of the LINAC96, Geneva, Switzerland, 1996.
7. California Tube Laboratory Advertising Brochures.
8. O.S. Milovanov Doctor of Sciences Thesis, MEPhI, Moscow, 1985.
9. A.V. Mishin Phase-locking and frequency tuning of CW magnetron using a CW klystron, 1998.