

# The RF Power Set Up for a Linac - Racetrack Microtron Combination.

R.W. de Leeuw, C.J. Timmermans  
Eindhoven University of Technology, Cyclotron Laboratory,  
P.O. Box 513, 5600MB Eindhoven, The Netherlands

## Abstract

The injection chain of the electron storage ring EUTERPE will consist of a 10 MeV travelling wave linac, followed by the 10 – 75 MeV Racetrack Microtron Eindhoven (RTME). As a cost effective solution both the linac and the microtron cavity are powered by a 2.2 MW peak power magnetron. In order to obtain synchronous operation of the two structures the linac magnetron will be injection locked to the RTME magnetron. This is achieved by coupling part of the power from this last magnetron via a 4-port circulator into the linac magnetron. This paper presents the RF power set up of the injection chain. Demands on the power sources are given. Stability measurements on the individual magnetrons and the combination of the two magnetrons are described.

## 1 INTRODUCTION

The 10 – 75 MeV Racetrack Microtron Eindhoven will serve as injector for the 400 MeV electron storage ring EUTERPE [1]. A standing wave accelerating structure [2] accelerates the 10 MeV injected beam in 13 steps to the final energy of 75 MeV. The injection energy of 10 MeV is achieved in a 2.2 m long travelling wave linac. Both the microtron's standing wave structure and the linac's travelling wave structure will be powered by an EEV M5125 magnetron. It was decided to opt for two magnetrons because this is seen as a cost effective solution, since magnetrons and modulator systems already were available at the laboratory. Moreover, it offers the advantage of reduced voltage levels over standard single beam klystrons. Disadvantage is of course the problem of synchronising two magnetrons, that has to be arranged at the high power level.

In sec. 2 the demands on the RF power sources of both linac and microtron will be discussed. In sec. 3 the measured frequency stability of a magnetron is presented. Sec. 4 gives a description of the experiment set up for the injection locking of the two magnetrons as well as the results of the experiment. Sec. 5 describes the proposed lay-out of the RF power set-up for the linac racetrack microtron combination and some concluding remarks are made.

## 2 DEMANDS ON THE MAGNETRONS

Tab. 1 lists details of the components of the RF power set-up. The linac has been used for radio-therapy purposes and therefore the RF power to beam conversion had to be optimised over a broad range of electron energies. At 10 MeV,

Table 1: Parameters of the RF high power set-up.

magnetron	EEV M5125
peak power magnetron (MW)	2.2
repetition rate (Hz)	50, 150, 300
<hr/>	
linac	
power dissipated in structure (MW)	1.00
power used for acceleration (MW)	0.55
macro pulse duration ( $\mu s$ )	1.7
filling time of structure ( $\mu s$ )	0.5
delay w.r.t. other magnetron ( $\mu s$ )	1.5
<hr/>	
racetrack microtron	
power dissipated in structure (MW)	0.91
power to second magnetron (MW)	0.20
power used for acceleration (MW)	0.50
macro pulse duration ( $\mu s$ )	3.6
filling time of structure ( $\mu s$ )	0.46

at a measured output current of 47 mA, only 1.55 MW of RF power is needed, the remaining power is dumped into a load. Of this 47 mA, only 7.5 mA will be accelerated further on in the microtron [3]. Details on the power consumption by the microtron cavity and its parameters are given in ref. [2]. The pulse lengths are dictated by the available hardware.

In longitudinal phase space the linac beam is accepted by the microtron within an interval of 18 degrees [1]. This implies that the maximum allowable phase deviation is  $\pm 9$  degrees. The allowable limitations on the amplitude variations of the magnetron ( $\pm 1\%$ ) and the phase deviation impose a demand on the frequency stability of  $\pm 50$  kHz (at a loaded  $Q$  value of 4100).

Since of the microtron's magnetron only 1.4 MW will be dissipated in the structure and by the beam, the remaining 0.6 MW can be used for phase locking purposes of the linac magnetron. In this locking procedure the microtron's magnetron with the longer pulse length will serve as master and the linac's magnetron as slave.

## 3 FREQUENCY STABILITY OF A MAGNETRON

For proper synchronous acceleration of the electron bunches by linac and microtron the phases of the two accelerating fields should be correlated as good as possible during the macro pulse. Off course also the inherent frequency stability

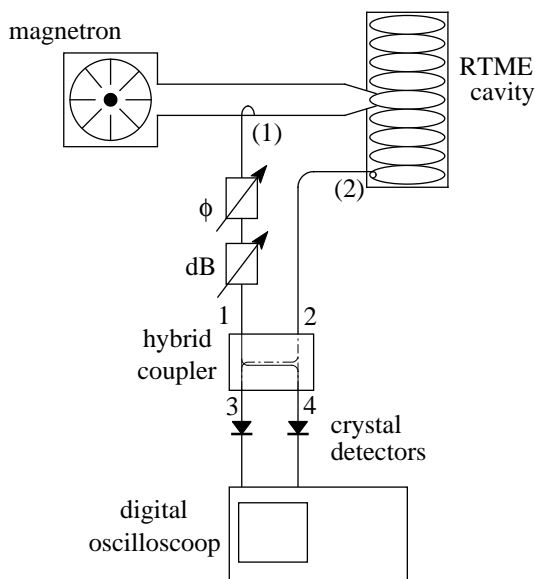

Figure 1: Schematic representation of the measurement set-up for the determination of the frequency stability of a magnetron.

of a magnetron during the macro pulse should be so that the phase variation of the accelerating field is sufficiently small.

It is not possible to measure directly the frequency of a pulsed signal generator with infinite accuracy. For a resonator operating at 3 GHz, with a pulse width of  $3.5 \mu\text{s}$ , the best one can achieve is an accuracy of approximately 100 kHz, in steady state operation corresponding with a phase difference of 19 deg. through a resonator with a quality factor of 5000. Therefore for our purposes this resolution is not enough.

However, if we are able to measure directly the phase shift through a resonator, due to the frequency changes of the generator, the required absolute resolution is far less. Fig. 1 depicts a measurement set-up, that uses this principle [4]. To generate the required phase shift, part of the signal is sent through a resonator with a relatively large  $Q_L$ -value and subsequently mixed with the unperturbed part of the signal.

Fig. 2 depicts the results of the measurement of the frequency stability of a magnetron. As resonator RTME's accelerating structure with a  $Q_L = 4125$  and  $\omega_0 = 2998.7$  MHz has been used [2].

Over a sufficiently large part of the total macro pulse of  $3.6 \mu\text{s}$  the magnetron displays no frequency variation. Therefore a magnetron can be used as a source of RF power for the Racetrack Microtron Eindhoven.

#### 4 INJECTION LOCKING OF TWO EEV M5125 MAGNETRONS

Fig. 3 depicts a schematic representation of the set-up for the two magnetron locking experiment, together with the detec-

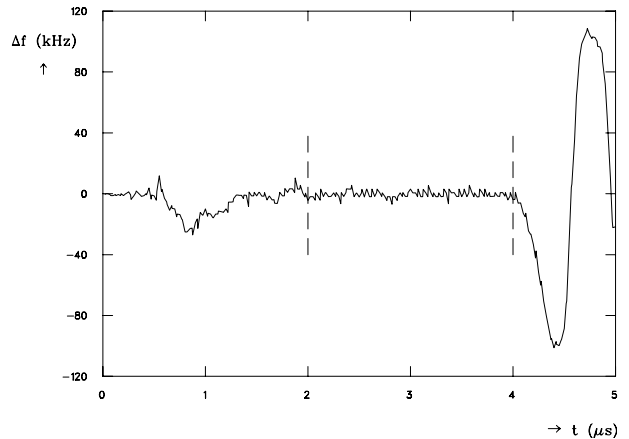

Figure 2: The measured frequency variation over the macro pulse of the magnetron that powers the cavity of the Race-track Microtron Eindhoven, the vertical scale only applies between the dashed lines.

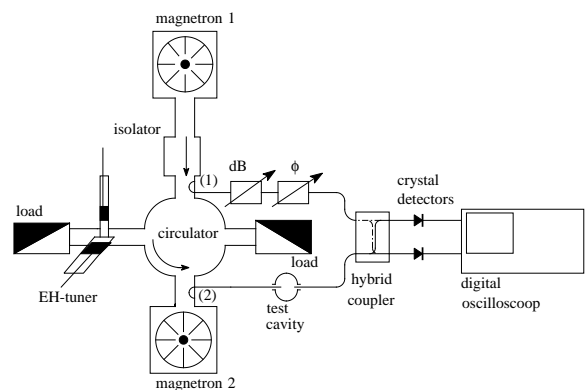

Figure 3: Schematic representation of the set-up for the injection locking experiment with two magnetrons.

tion circuit.

Magnetron 1, the master, delivers its power via an isolator to port 1 of a circulator. Via the first output port, port 2, of the circulator, the power reaches an EH-tuner: a magic T with movable plungers in the H- and E-waveguide arms. By adjusting the position of the plunger in the H-waveguide arm part of the power is reflected back towards the circulator. The rest of the power is absorbed in the matched load after the EH-tuner. The reflected power is delivered via port 3 to magnetron 2, the slave. The output power from this magnetron is delivered via port 3 (input) and 4 (output) of the circulator to a second matched load.

By means of two directional pick-ups in the waveguide, part of the power from magnetron 1, pick-up (1), and magnetron 2, pick-up (2) is coupled out of the waveguide and is used as input for the same frequency detection set-up as used in sec. 3.

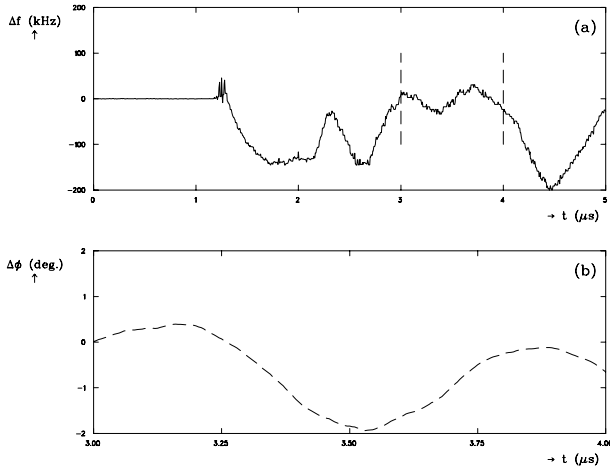

Figure 4: (a) The measured frequency difference between the two magnetrons, the vertical scale only applies between the dashed lines, (b) the integrated phase difference between the two magnetrons over part of the pulse.

Fig. 4.a depicts the measured frequency difference between the two magnetrons in the master-slave configuration in fig. 3 for a locking power of 100 kW. Clearly visible is the close frequency relation between the two magnetrons for the time interval (3 – 4)  $\mu$ s. In fig. 4.b the frequency difference between 3 and 4  $\mu$ s is integrated into a phase difference between the two signals. When no power was sent from master towards slave no frequency correlation between the two signals was found. However, the pattern does not change considerably for higher locking powers (200 – 400) kW. The angle between the two signals varies with the square root of the amount of locking power.

The initial frequency difference between the two free running magnetrons was as much as  $\sim 1$  MHz. The slave magnetron is triggered  $\sim 1.5 \mu$ s after the master magnetron. The output power of the slave magnetron is independent of the amount of injected locking power and equal to the free running output power.

If the signal from the master oscillator is considered to be constant and the oscillations are subscribed solely to the slave magnetron, the accelerating field in the linac will display phase variations of the order of degrees ( $\leq \pm 6$  degrees), within the acceptance limitations of RTME.

## 5 THE RF POWER SET-UP OF THE LINAC-RACETRACK MICROTRON COMBINATION

The combination of two injection locked EEV M5125 magnetrons generates enough power for the accelerating structures of the accelerator injection chain of the electron storage ring EUTERPE. Fig. 5 depicts the proposed lay-out of the high power RF set-up of the linac-racetrack microtron combination based on the two injection locked magnetrons.

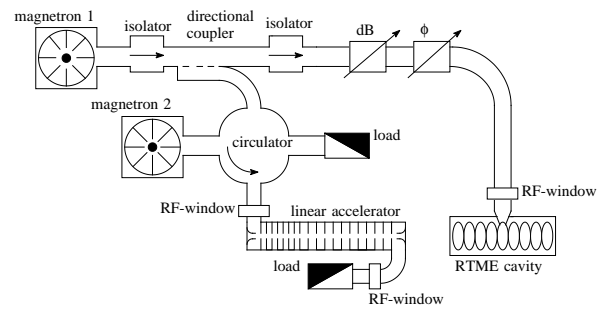

Figure 5: Schematic representation of the RF power set-up of the linac-racetrack microtron combination.

The magnetron that powers the accelerating structure of the Racetrack Microtron Eindhoven operates as master in the locking scheme (magnetron 1). Part of the power of this magnetron will be coupled out via a directional waveguide coupler and is sent via a circulator towards the second (slave) magnetron. The remaining power is delivered via an attenuator, a phase shifter and an isolator to the accelerating structure. The slave magnetron powers the linac.

## 6 REFERENCES

- [1] Webers G.A., *Design of an electron-optical system for a 75 MeV racetrack microtron*, Ph.D. Thesis, Eindhoven University of Technology (1994).
- [2] Leeuw R.W. de, Coppens J.E., Drouen T., Timmermans C.J., Botman J.I.M., Hagedoorn H.L., *The accelerating cavity of the Racetrack Microtron Eindhoven*, this Proceedings.
- [3] Leeuw de R.W., Wijs de M.C.J., Webers G.A., Hagedoorn H.L., Botman J.I.M., Timmermans C.J., *Matching the emittance of a linac to the acceptance of a racetrack microtron* Proc. Part. Acc. Conf., Dallas (1995).
- [4] Leeuw R.W. de, *A magnetron as a source of RF power for RTME ?*, Internal report VDF/NK 94-13, Eindhoven University of Technology (1994).