

PCI TO CAMAC EXECUTIVE CRATE CONNECTION

S.G. Kadantsev*, E. Klassen, M.M. Mouat, P.W. Wilmshurst
TRIUMF, 4004 Wesbrook Mall, Vancouver, B.C., Canada V6T 2A3

Abstract

TRIUMF's Central Control System has a large investment in CAMAC. To protect this investment but allow the current trend of PCI-bus based computers to be supported, TRIUMF has configured a PCI to CAMAC system. In this setup, TRIUMF has connected PCI based computers into the CAMAC equipment of their Central Control System. DEC Alpha computers running OpenVMS have been interfaced via the PCI bus to the existing CAMAC executive crates. The PCI bus is connected to a Q-bus expansion chassis using a commercial interface and then from the Q-bus chassis to CAMAC via a TRIUMF interface. This paper describes the hardware and software interfaces, and performance issues.

1 INTRODUCTION

The TRIUMF central control system consists of several CAMAC[1] highway systems (Figure 1). Each is based on a GEC executive crate system[2] which allows multiple hosts, until recently only VAXes and old Data General Novas, to address any of the serial or parallel branches in the system. A pair of TRIUMF designed executive crate interfaces (0782/0783 modules) form the connection between the Q-bus of a VAX and the GEC executive crate. The 0782 connects to the Q-bus via the VAX's chassis or expansion chassis and the 0783 is located in the executive crate. This architecture allows multiple VAXes to access multiple executive crates and is found to be quite flexible.

Currently, many manufacturers support the PCI local bus. DEC supports the PCI local bus on a variety of computers including its Alpha workstations and servers. A project was embarked on using the PCI bus on an Alpha Server 2000 4/200 and an Alpha Station 600 5/266 to access the CAMAC highway in the OpenVMS environment. Since the existing Q-bus to executive crate interface works well, the possibility of using a PCI to Q-bus adapter was considered. The software driver had to be modified to accommodate the new hardware interface and run on Alphas under OpenVMS.

2 HARDWARE INTERFACE

The BCI-2100 Q-bus adapter for the PCI local bus from the Logical Company[3] was chosen. It provides the means to connect Q-bus controllers to a computer with a PCI local bus. The PCI Q-bus adapter consists of a BCI-2100 PCI controller, a CAQ-2101 Q-bus module, and a CAB-1104-8 interconnect cable (See Figure 2). The PCI Q-bus adapter enables the computer to read and write to the Q-bus address space and to control Q-bus interrupt requests and DMA transfers.

The BCI-2100 controller is a standard short card that contains circuitry to interface to the PCI and to the Q-bus. This includes Q-bus termination as well as a high density connector to carry the Q-bus signals. The controller contains optionally 256 Kbytes or 1 Mbyte of memory for storage of Q-bus DMA data. Internal registers for control and status are also present.

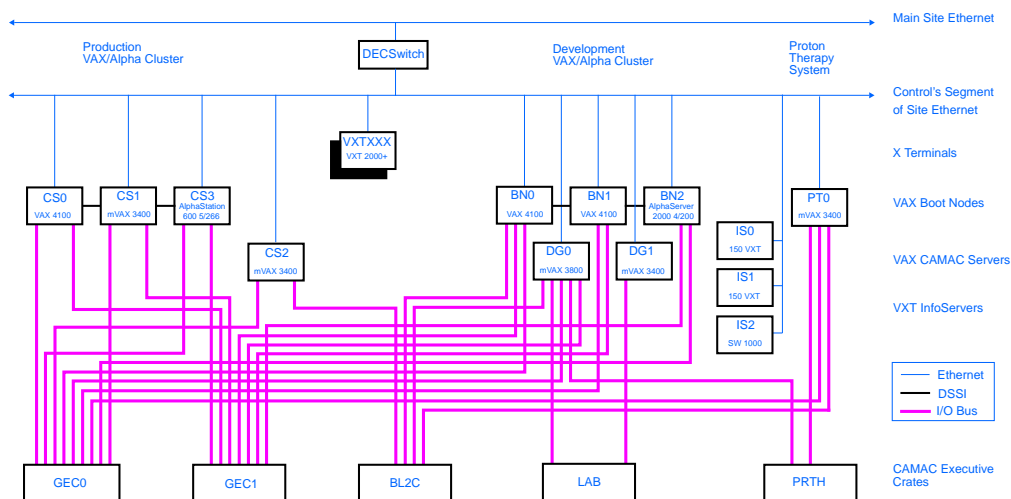

Figure 1: TRIUMF's Central Control System Configuration

* On leave of absence from the Joint Institute for Nuclear Research, Dubna.

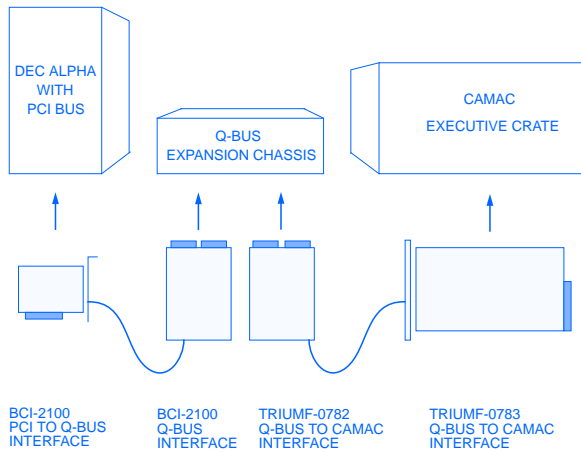

Figure 2: PCI Bus to CAMAC Executive Crate Setup

The CAB-1104-8 cable is eight feet long and consists of a twisted pair shielded cable terminated at each end with high density connectors. The cable is used to connect the PCI controller to the Q-bus module or I/O panel. The 0782 to 0783 cable has been tested to a length of 100 feet.

The CAQ-2101 Q-bus module provides the means to connect to the Q-bus signals contained in an expansion chassis or into user equipment containing a Q-bus cable connection. Two models of the CAQ-2101 are available to accommodate various chassis styles.

The Logical Company provided the diagnostic software for testing the functions of BCI-2100.

3 SOFTWARE INTERFACE

The existing software interface provided both standard and non-standard IEEE CAMAC calls in the VAX OpenVMS environment for the Q-bus configuration. This software driver was ported from VAX to Alpha OpenVMS environment to accommodate the PCI local bus interface.

The 0783 interface card has seven registers: CSR, POL, IHR, IMASK, AF, DBL, and DBH. All CAMAC operations either read or write these registers. CAMAC cycles are triggered by a write to the AF register and the completion of the operation is indicated by status bits in the POL register (Figure 3).

PCI device address assignments are defined by an Alpha host during configuration. If a device is present, the host obtains device information and the amount of PCI address space required to service the device.

The PCI control address space is defined at configuration time by the PCI configuration register BADM. The Q-bus control address space is defined at configuration time by the PCI configuration register BADLA. This register defines an address space of 2 Mbytes, 1 Mbytes for SIMM memory, 946 Kbytes for Q-bus address space, and 64 Kbytes for the Q-bus control registers.

The Q-bus PIO address space (Figure 4) is divided into

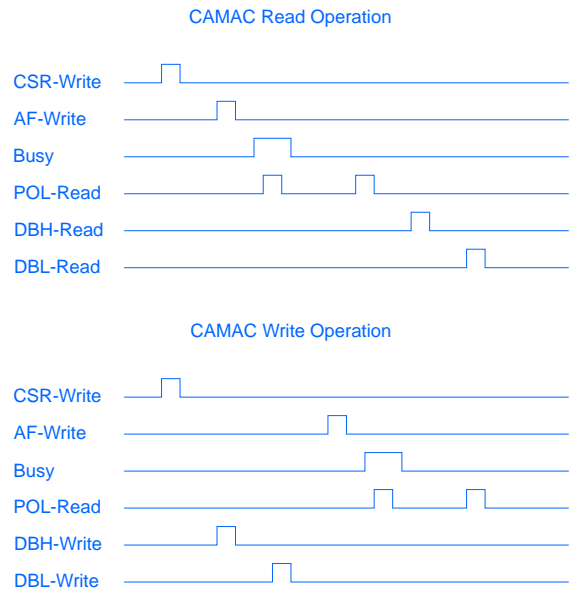

Figure 3: Signal Diagram of the Typical CAMAC Read and Write Operations

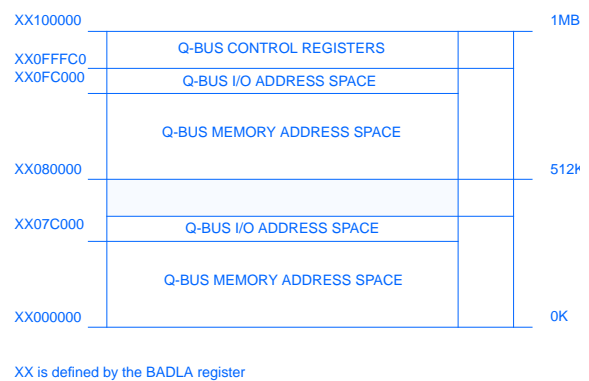

Figure 4: Q-bus PIO Address Space

two 512 Kbyte areas. The lower address area is used for Q-bus access to 18-bit memory and I/O. The upper address space is used for Data In/Out access to 18-bit memory and I/O. The upper 64 Kbytes of Data In/Out address space is used to address internal Q-bus control registers. The Alpha host can access 256 Kbytes of Q-bus space including memory and I/O by referencing a range of addresses on the BCI-2100. The five types of Q-bus data transfers supported are read word, data I/O, write word, write lower byte, and write upper byte.

The program was rewritten from VAX MACRO to C and the following calls are available:

- CDREG combines the components of branch, crate, slot and address code into a single CAMAC register reference;
- CFSA performs a single CAMAC function;
- ZAP provides read/write to addresses in the I/O space;

Table 1: A CAMAC cycle duration within the driver's locked block

System	Read, μ s	Write, μ s
AlphaServer 2000	15.0	8.0
AlphaStation 600	10.5	10.1
VAX 3800	15.6	11.7
VAX 4105	15.3	13.1

Table 2: Number of CAMAC cycles per second within an OpenVMS application program

System	Read	Write	Non-data
AlphaServer 2000	13,400	14,002	14,000
AlphaStation 600	32,775	33,395	39,240
VAX 3800	12,978	13,728	14,800
VAX 4105	37,000	40,660	47,000

- EXEC_CRATE allows inquiry and changes of the 0783 register offset which enables the caller to select more than one executive crate interface attached to that computer;
- READ_IHR, READ_IMASK, WRITE_IMASK, SET_IMASK_BIT, CLEAR_IMASK_BIT, SCI\$READ_POL, and SCI\$TEST_ONLINE allow inquiry and changes of other 0783 registers;
- MON\$ENABLE, MON\$DISABLE, MON\$GET_DATA, MON\$SKIP, and MON\$CLEAR provide the trace mode.

Although BCI-2100 supports DMA mode, only programmed I/O type CAMAC access is implemented due to arbitration in an executive crate. Since a formal device driver will incur more overhead for each CAMAC call, the software interface is implemented as an installed, privileged shareable image. To increase its availability, the driver has been installed in the granularity hints code region.

The actual CAMAC access code is executed in kernel mode. To synchronize process access to a shared resource, the critical blocks of code are locked by raising the interrupt priority level to 31.

4 PERFORMANCE

Table 1 shows the average CAMAC cycle duration within the driver's locked block, i.e. from the moment of writing to CSR to the last reading of POL or data register.

Table 2 shows the number of CAMAC cycles per second performed within an OpenVMS application program. PCI bus computers have a disadvantage in this configuration in that they must make multiple accesses to the PCI bus for Q-bus register access.

5 SUMMARY

TRIUMF has configured a PCI to CAMAC system to protect its investment in CAMAC and to allow the current trend of PCI bus computers to be supported. A PCI to Q-bus adapter, the BCI-2100 from the Logical Company was used. The software driver has been modified to accommodate the new hardware interface and now runs on a DEC AlphaServer 2000 4/200 and an AlphaStation 600 5/266 under OpenVMS.

6 REFERENCES

- [1] CAMAC Instrumentation and Interface Standards, New York, IEEE, 1982.
- [2] GEC-Elliott Process Automation (now HYTEC Electronics Ltd) System Crate Catalogue, 1982.
- [3] BCI-2100 Q-bus Adapter for the PCI Local Bus, The Logical Company, 1995.