

CONCENTRIC RING COLLIDING BEAM MACHINE WITH DUAL APERTURE QUADRUPOLES¹

A. Mikhailichenko, D. Rubin

Cornell University, Wilson Lab, Ithaca, NY, 14850

In the Cornell Electron Storage Ring, the orbits of electrons and positrons are separated horizontally. The trajectories of the beams intersect as the horizontal betatron phase advances through half wavelengths, limiting to 45 the number of bunches that can be stored in each beam. If the CESR quadrupoles are replaced by double bore, side by side magnets, then the counterrotating beams travel concentric orbits that intersect only at the interaction point. The bunches can be placed evenly about the circumference of the ring and as many as 180 bunches accommodated. Both beams must remain within the good field region of the CESR bending magnets. As a result, the distance between the centers of the side by side lenses can be no greater than 81mm. This separation defines the radial separation of the beams. A superconducting dual bore magnet with twin full apertures of 54 mm and axes separated by 81 mm has been designed and a prototype fabricated. We report details of the concentric ring scheme and properties of the magnet.

1. Introduction

In the concentric ring machine [1] the beams collide with a 2.3mrad half-angle. The small crossing angle provides for separation of the bunches near the IR, and is consistent with the finite aperture of the existing CESR IR quads. The approximately $10\sigma_x$ horizontal separation generated by the crossing angle is doubled with the help of an electrostatic deflection so that the beams will clear a septum. The separator is located just beyond the horizontally focusing quadrupole. The configuration and corresponding orbits are indicated in Figure 1.

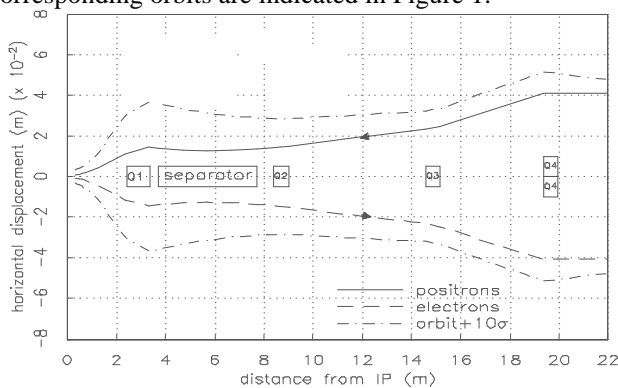

Figure 1. Trajectory and orbit $10\sigma_x$ for both beams east of IP. Beams clear center wall of a dual aperture quadrupole 19.5 m from IP, the nominal location of Q4.

The magnet labeled Q3 in the figure is a large aperture

quadrupole like Q1 and Q2. Throughout the remainder of the machine, the beams share the existing dipole bending field, but are directed through side-by-side quadrupoles. The incoming beam travels through the outer quadrupoles and the outgoing beam through the inner quadrupoles. Orbit lengths for the two beams are the same as the inner and outer beams change roles at both the interaction point and the diametrically opposed symmetry point. All long range beam-beam parasitic interactions are eliminated except for those nearest the IP.

2. Aperture

The possibility of installing separate rings within the CESR dipoles is based on the observation that there exists at present considerably more horizontal aperture in the vacuum chamber than a single beam requires. Our experience with multibunch pretzel operation demonstrates that considerably less than the $\pm 4.5\text{cm}$ horizontal aperture is needed. In practice we find that $\pm 7.5\sigma$ is adequate. In crossing angle optics with $Q_h=10.52$, $\epsilon_x = 0.22 \cdot 10^{-6} \text{m} \cdot \text{rad}$ (including two wigglers, 0.195 with one wiggler), $\beta_x^{\text{max}}=40 \text{m}$, and $\eta_x^{\text{max}}=3.9\text{m}$. Then $\sigma_x < 3.64 \text{mm}$ and required horizontal aperture is $A_x = \pm 2.7\text{cm}$. (We assume that we will be able to arrange the optics so that each beam traverses only one wiggler and include only the contribution of one wiggler to the emittance.) We can accommodate two beams in the dipole gap if the good field quality extends over $4 \times 2.7 \text{cm} + t$, where t is the thickness of the septum of bi-center quad boundary.

3. Dipole

As noted above, we are assuming a uniform dipole field over at least $4 \times 2.7\text{cm}$. The variation in the CESR dipole field is less than 1 part in 4000 over a 9cm stretch. We propose to extend the good field region by adding lips at the outskirts of the laminations, as shown in the Figure 2. In order to make space for the lips, one turn on the lower pancake is removed. The current through the remaining coil would necessarily increase 15%. The vertical magnetic field on the horizontal axis of the magnet, as computed by Poisson is shown in Figure 3. The field varies by less than 1 Gauss over a horizontal span of 13.5 cm. Note that in order to achieve the requisite field quality, the shims on the existing dipole have been modified and/or eliminated. We conclude that the separation of the chambers in the dual aperture quadrupoles can be no more than $13.5 - 4 \times 2.7 = 2.7 \text{cm}$.

¹ Work supported by National Science Foundation.

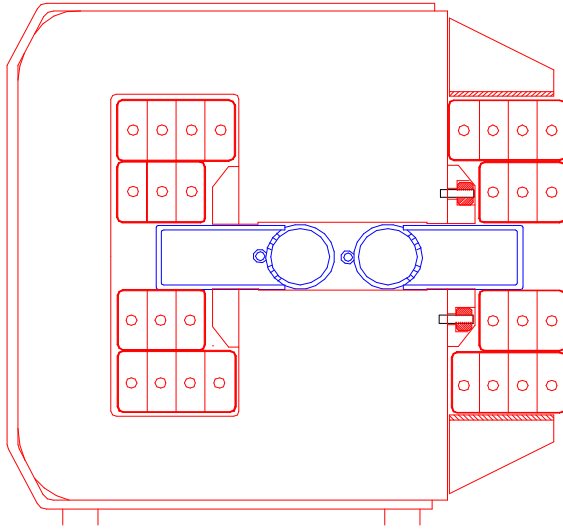

Figure 2: The CESR dipole magnet with lips and an example of a dual vacuum chamber.

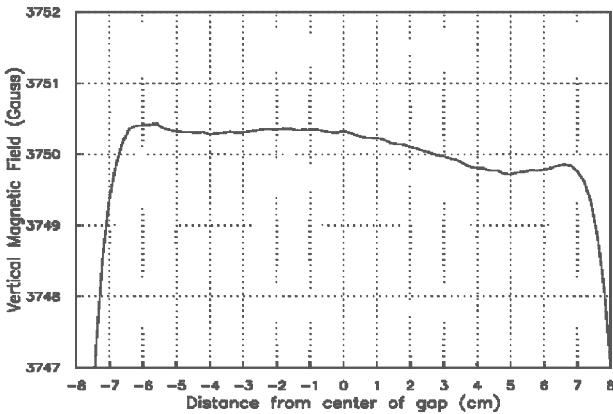

Figure 3: The vertical component of the magnetic field along the midplane of the gap for the dipole with lips.

4. Dual Aperture Quadrupoles

In view of the above, the basic design parameters of the side by side quadrupoles, are good field apertures of $\pm 2.7\text{cm}$ in each bore and separation of the lens' axes of 8.1cm . Tracking studies indicate that fractional error with respect to pure quadrupole field $\Delta B/B < 4 \cdot 10^{-4}$. Requisite focusing strength is 0.4m^{-2} at 5.3GeV . Because the side-by-side lenses have nominally equal gradients, the magnetic field changes sign across the boundary between them. Therefore, the current density within that region is necessarily high. Indeed such densities are impractical for a normal magnet, but modest if the magnet is superconducting. We have designed, built and tested a superconducting magnet that promises to satisfy the design criteria.

The cross section of the magnet is shown in Fig.4. The length of the yoke (along the beam trajectory) is about 380mm . The coil has one layer, arranged with 43 turns of NbTi wire of 0.43mm in diameter with 54 filaments. At the design current of 150A , the field gradient is about 1.16kG/cm . The yoke is placed in a helium dewar that is

not shown on this figure. The critical magnetic field for this current is about 5T at 4.2K well above the design peak field of 0.4T . Eight of these coils are used to assemble each pair of quadrupole lenses.

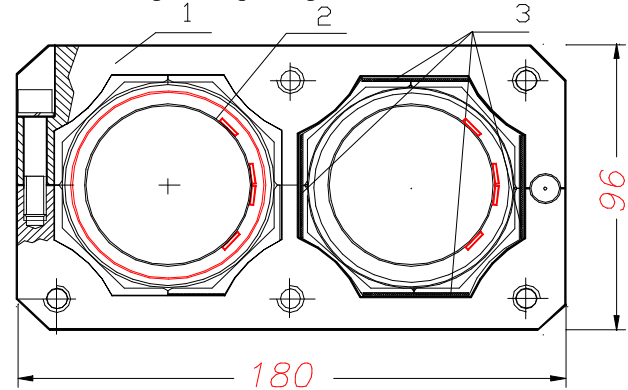

Figure 4: Cross section of the core of dual bore magnet. 1--the yoke, 2-- the inner vacuum chamber, 3 -- the coils.

4.1. Design of the coil and yoke parameters is based on an analytic calculation for the central region of the lens aperture [2]. A numerical code is used to evaluate the effect of errors in manufacture. Of particular concern is the dependence of the field quality in one lens on the current in the coils of its neighbor. The thickness of the septum yoke is chosen so that even if the currents in the adjacent lens differ by a factor of 10, the effect on field quality is less than a part in 10,000. Special iron shielding

is used to minimize this effect in the fringe field region.

4.2. Assembly The upper and lower halves of the magnet yoke are machined from solid iron. Tolerances of 0.04mm are required to achieve adequate field uniformity. The coils are wound flat in a single layer racetrack configuration and folded to fit about the poles of the yoke. The coils are fixed with epoxy. Removable end iron can be custom shaped to reduce multipoles. The view of the magnet assembled is represented in Fig. 5.

4.3. Field Measurements are made in a standard helium dewar, Figure 6. The magnet and measurement instrumentation are fixed to the upper flange. Concentric tubes are inserted through the center of each lens. The space between the tubes is evacuated and filled with super insulation. A short measurement coil (40mm) and a long coil (500mm) are mounted on a fiberglass rod that is inserted into the inner tube (warm bore) of the magnet. The measurements were done using the rotating coil method [2]. A stepping motor (8) (Fig.6) with transmission mechanism rotates the rod (19) with the short and long coils on it. The opposite end of the rod is fixed so that it is centered in the tube and magnet aperture. During a single revolution of the rod, which takes about 70 second, the 16 bit ADC makes about 400 readings. The electronics are controlled by a PC with ADC and stepping motor boards inside.

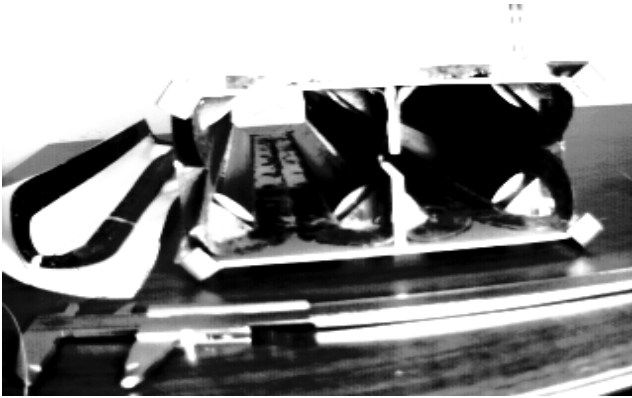

Figure 5: The dual bore quadrupole magnet. One of the SC coils is shown at the left .

The measurement of the field harmonics integrated over the length of the magnet with respect to pure quadrupole field are give by (x in cm) :

$$B(x)/G \cdot x = 1.2 \cdot 10^{-3} x - 2.2 \cdot 10^{-7} x^2 + 6.7 \cdot 10^{-6} x^3 - 3.0 \cdot 10^{-5} x^4$$

The relatively large sextupole component is thought to be due to mechanical imperfections. The maximum current was 200 A, generated the gradient up to $G=1.55$ kG/cm.

5. Dual aperture dipole correctors, skew quadrupoles, sextupoles and octupoles A practical implementation of the concentric rings requires dual aperture corrector magnets, including sextupoles and skew quadrupoles. We have designs for all magnets similar to the superferic quadrupole described above.

6. Vacuum

The demands on the vacuum system depend on the total current. Our experience in crossing angle operation suggests that the beam-beam limit is 10 or 11 mA per bunch for $\beta_v^* = 18mm$. A 28 ns bunch spacing corresponds to 90 bunches/beam in CESR and a total current of nearly 1A/beam. Evidently the luminosity of such a machine would be limited by the availability of RF power and the quality of the vacuum system. The existing CESR vacuum system is anticipated to be adequate to operate with 1A total current in both beams. Concentric chambers of comparable quality would permit operation with 1A in each of the two beams.

7. RF system

In the concentric ring scenario the counterrotating beams, 8 cm apart, share the same accelerating cavities. The single cell superconducting cavity soon to be installed in CESR has a 12 cm radius, so there is more than sufficient physical aperture. The beam displacement corresponds to 1/3 of the radius of the beam tube. A crude estimate of the impact of dynamical effects follows an extrapolation from existing conditions. In present operation with a crossing angle and bunch trains, the beams are displaced by about $\pm 1-1.2$ cm, or about 1/4 of the beam tube radius, in the 5-cell copper cavities. There will be 4 superconducting cells, as compared to the exist-

ing 20 normal conducting copper cells. The total impedance will be somewhat less for the superconducting system than for the existing system. In addition, the Q-factor of relevant parasitic modes will be lower in the superconducting cavities due to HOM damping system.

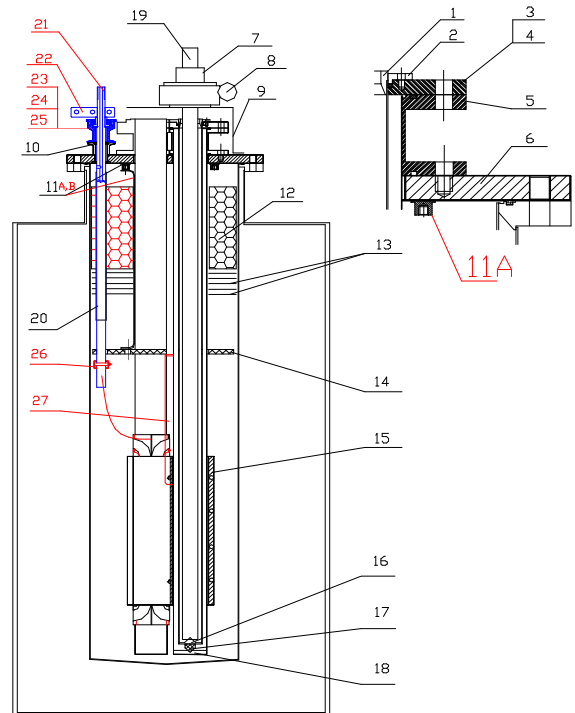

Figure 6: The testing device. 1-4 the sealing of the inner tube to the intermediate flange 5, 6- the main flange, 7-holder, 8-stepping motor, 9- support, 10-the input of the current leads, 11-holding nuts, 12,13- thermoinsulation, 14-intermediate plate, 15-the magnet yoke, 16-18 supports for intermediate tube and for fiberglass rod 19, caring the coils, 20-26 -current leads, 27- attachment of the yoke to the plate 14.

8. The Rest of the Ring

The rings cross over and under halfway around the ring, so that the guide fields explored by each beam are anti-symmetric. If electrons travel the inner ring in the East and positrons the inner ring in the West, modification to the injection transfer lines is minimal. Independent steering, focusing and sextupole fields at each of the quads provide flexibility to separate the beams at the IP during injection, and optimize beam-beam performance.

9. Conclusion

We have designed and built a dual aperture quadrupole that provides the basis for upgrading CESR to operate with concentric rings. The authors thank Tobey Moore for his help in assembling the magnet and Vivek Jain from Vanderbilt University for his participation in the measurements.

References

- [1] D. Rubin, M. Tigner, "Shared bends and independent Quadrupoles", CON 94-28, 1994.
- [2] A. Mikhailichenko, "3D Electromagnetic Field. Representation and measurements", CBN 96-16, 1995.