

Quench Propagation Tests on the LHC Superconducting Magnet String

L. Coull, D. Hagedorn, G. Krainz, F. Rodriguez-Mateos, R. Schmidt, CERN, Geneva, Switzerland

Abstract

The installation and testing of a series connection of superconducting magnets (three 10 m long dipoles and one 3 m long quadrupole) has been a necessary step in the verification of the viability of the Large Hadron Collider at CERN. In the LHC machine, if one of the lattice dipoles or quadrupoles quenches, the current will be by-passed through cold diodes and the whole magnet chain will be de-excited by opening dump switches. In such a scenario it is very important to know whether the quench propagates from the initially quenching magnet to adjacent ones. A series of experiments have been performed with the LHC Test String powered at different current levels and at different de-excitation rates in order to understand possible mechanisms for such a propagation, and the time delays involved. Results of the tests and implications regarding the LHC machine operation are described in this paper.

1 INTRODUCTION

Within the R&D program for the Large Hadron Collider (LHC) [1], a string of three 10 m long dipole magnets and one 3 m long quadrupole magnet has been assembled at CERN [2]. Experiments on cryogenics, vacuum and magnet protection have been performed since the beginning of 1995 [3].

From the electrical point of view, the LHC machine will be sub-divided into octants. In each octant, the main lattice quadrupole and dipole magnets will be independently powered in separated circuits. The protection of such magnets in case of a quench is based on quench heaters [4] and cold by-pass diodes [5]. Once a quench is detected, the quench heaters are fired and warm-up a large fraction of the outer coils, provoking a large electric resistance growth. The current will then commutate from the quenching magnet over to the cold by-pass diodes connected in parallel.

The magnets which do not quench are de-excited by switching off the power converter and opening switches, with resistances in parallel which give a time constant for the de-excitation of around 100 s for the dipoles circuit, and of around 45 s for each of the quadrupoles circuits.

The number of magnets quenching in the same circuit should be limited to a minimum : it may become a dangerous hazard for some elements of the magnet protection system (namely, high reverse voltages might appear across a number of cold diodes). The cryogenic recovery of a quench of many magnets takes a long time. Typically, multiple quenching can be provoked by thermo-hydraulic quench

propagation, by excessive negative dI/dt , by beam losses, or by a global quench detection or control system error [6].

It is essential to know if the quench in one of the LHC superconducting magnets will propagate to the neighbouring magnets, and to understand possible mechanisms of a propagation.

2 QUENCH PROPAGATION TESTS

In the original design of the LHC machine the quench protection acted at the half-cell level, firing the heaters of all the magnets in the case of a quench detected in one of the magnets. In order to have a test set-up to study inter-magnet quench propagation the "half-cell" was modified according to the electrical scheme shown in Figure 1. The by-pass of the quadrupole magnet is made with three cold diodes which allow for a discharge with a time constant constant of up to 120 s from full current. The by-pass of the dipole magnets is performed by means of a set of four diodes with fine leads connecting intermediate points between magnets and between diodes. The fourth diode is not in use. The fine leads are limited in terms of current load due to their small copper section (27 mm^2) which did not allow quench propagation studies between dipole magnets. More details on the magnet protection system and on the powering system of the LHC String are given in [7].

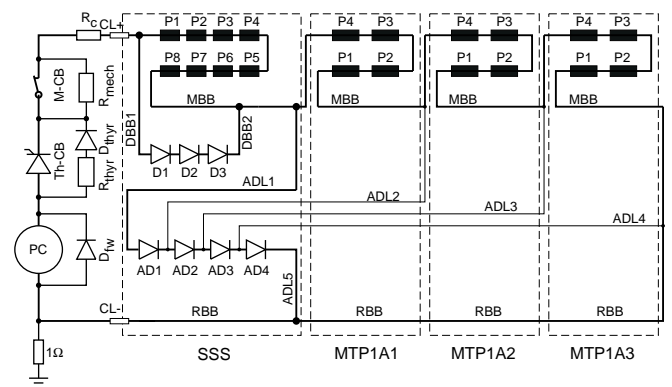

Figure 1: Electrical diagram of the string with one quadrupole magnet and three dipole magnets

For our experiments a quench is provoked by firing the heaters of the quadrupole at different current levels. The power converter is switched off, and the thyristor switch is opened to de-excite the dipole magnets with a time constant of about 100 s. As shown in Figure 2, the dipole magnets

quench during the de-excitation some tens of seconds later if the initial current exceeds 5 kA. Once a quench is detected in one of the dipole magnets, heaters are fired in all three dipole magnets and the current decays to zero within several hundred milliseconds.

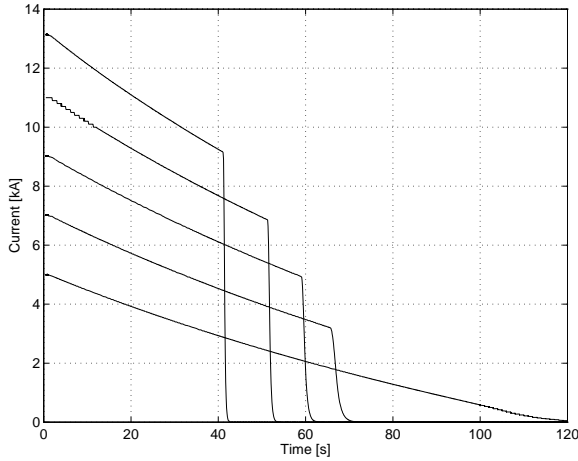

Figure 2: Current versus time after provoking a quadrupole quench with quench heaters. When the current exceeds 5 kA, the dipole magnets quench after some ten seconds

All tests were performed at a bath temperature of 1.9 K. The present configuration of the string includes two quench relief valves at each end of the magnet chain. Prior to the quench propagation experiments tests have been performed [8] to study the dependence of transient pressure peaks in case of a quench on the number of active valves and on the timing of their opening. For the experiments presented here both type and opening time of the relief valves were varied.

In the analysis of the data taken during the quench we try to find out whether the quench propagates through the bus-bar which connects the diode triplet and the main bus-bar between quadrupole and first dipole magnet (solid heat conduction mechanism), or if the warm Helium front expelled from the quadrupole cold mass causes the dipole to quench (thermo-hydraulic mechanism).

3 INSTRUMENTATION

The evolution in time of voltages, temperatures and pressures are measured by instrumentation probes. All quench protection diodes are directly immersed in the superfluid Helium bath. For the analysis of the quench propagation mechanism the probes situated between quadrupole and dipole are of particular importance. Figure 3 shows the position of some of the temperature sensors (Carbon type) and voltage taps in the diode region and adjacent bus-bars.

In addition, pressure sensors and temperature probes (C and Pt 100) are located in the end volumes of each superconducting magnet, typically glued on to the end plates at the extremities of the coil assemblies.

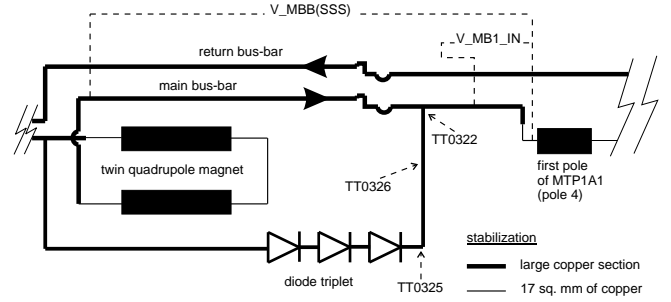

Figure 3: Layout of 5 m long string section from quadrupole to dipole magnet indicating voltage taps and temperature sensors

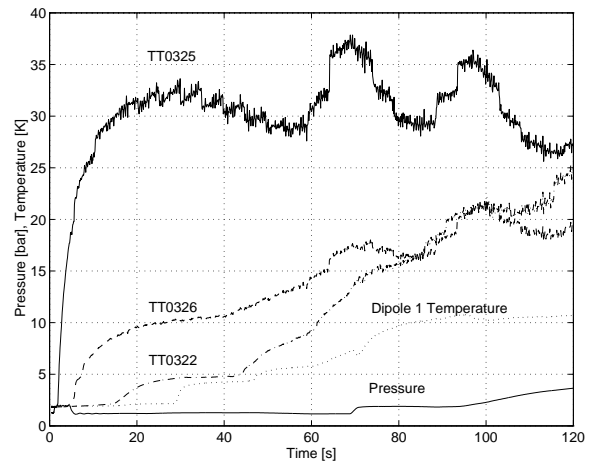

Figure 4: Temperature versus time for a quench with an initial current of 7 kA. The dipoles quench after 66 s

4 RESULTS AND INTERPRETATION

In Table 1 the parameters for the experiments are summarized : initial current, the current at which the dipole quenches, the delay for opening of the quench relief valve after the provoked quench in the quadrupole, the delay for the dipole quench, and the peak pressure observed.

The time between the quadrupole quench and the quench of the dipole for an initial current of 7 kA is about 60 s. With

initial current [A]	dipole quench at [A]	valve delay [s]	dipole quench after [s]	max. pressure [bar]
7000	3350	opens after dipole quench	63	11.5
7000	2600	35	79	7.9
7000	3250	5	66	3.5
9000	4920	5	59	1.3
11000	6900	5	51	1.5
11000	6600	25	54	8.1
13100	9030	5	42	1.2

Table 1: Parameters for the experiments

13.1 kA this time decreases only slightly to about 40 s, although the released energy is 3.5 times higher and the temperature margin of the cables in the dipole is much lower. For an initial current of 7 kA the time could be changed from 66 s to 79 s by changing the opening time of the quench relief valve from 5 s to 35 s. When the valve was not opened, the dipole quenched after 63 s, although the Helium pressure in the cold mass increased to about 11 bar.

After initiating a quench in the quadrupole, the current in the quadrupole commutates over to the diode triplet within less than one second. The string current then decays with a time constant of 100 s, heating up the diode triplet. The diode heat sink temperature rises up to about 100 K. Most of the heat will be exchanged with the surrounding Helium, while part of it will propagate along the highly stabilized diode bus-bar. Carbon sensors at the beginning and in the middle of the diode bus-bar, and at the connection to the main bus-bar show this heating effect for a quench at 7 kA (see Figure 4).

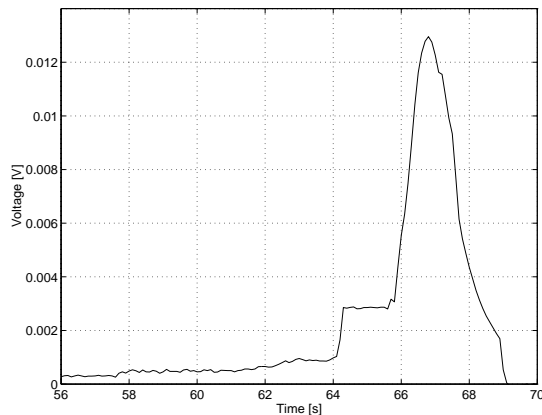

Figure 5: Voltage V_MBB(SSS) (see Figure 3) versus time for a quench at 7 kA

The diode bus-bar at position TT0325 heats up immediately due to the closeness to the heat sink. TT0326 shows already a delay of 5 s before heating becomes so strong that Helium II vaporizes. After 15 seconds TT0322 starts warming up from 1.9 K to Helium I temperature (4.2 K) and stays at this level for some seconds until the surrounding Helium is vaporized.

The absence of Helium II around the bus-bar diminishes the heat transfer from the latter to the bath. Propagation through the 2 m long main bus-bar at the interconnection between the quadrupole and the first dipole magnet needs about 40 s at this current level. The temperature in the main bus-bar (TT0322) exceeds the critical temperature of the Niobium-Titanium superconductor, and hence it is the copper stabilizer which takes over the current. The signals from the voltage taps across the main bus-bar confirm this interpretation. Close to the dipole coil the copper section of the main bus-bar is reduced from about 300 mm² to 17 mm². A voltage measurement across this transition area (see Figure 5) shows a fast increase in voltage of about 2 mV just

before the quench is detected in the dipole magnet. A similar scenario to this has been found in all the experiments at different current levels. The voltage jumps are proportional to current.

It has been observed that the pole of the first dipole connected to the main bus-bar always quenched first. This is another indication for a propagation through the main bus-bar as the origin for the quench in this magnet. Different opening delays of the quench relief valve showed that only a weak correlation exists between the pressure in the cold masses of the magnets and the delay for the dipole to quench.

5 CONCLUSIONS

Quench propagation studies on the LHC String indicate that the thermal propagation after quadrupole quenching from the diodes through the bus-bars leads to a quench of the dipole. The main delay is given by the length of fully stabilized bus-bar which is 2 m in the string but will be at least 15 m in the LHC machine. However both magnet and cryostat construction will be different, and the experiments will need to be repeated when for the next generation string a half or full cell is assembled. The results show that a high pressure in the cryostat after a quench of one magnet does not lead to an immediate quench of other magnets. In the design of magnet and diode connections for the LHC the thermal propagation through bus-bars needs to be fully studied.

6 ACKNOWLEDGEMENT

The authors are very grateful to B. Hilbert and L. Serio for preparing the cryogenic conditions for the tests and for many helpful discussions. Thanks also to A. Alvarez and to A. Rijllart for their collaboration on the data recording.

7 REFERENCES

- [1] The LHC Study Group, The Large Hadron Collider: Conceptual Design, CERN/AC/ 95-05 (LHC)
- [2] P. Faugeras for the LHC String Team, Assembly and Commissioning of the LHC Test String, PAC, Dallas, USA, May 1995
- [3] A. Bezaguet et al., The LHC Test String: First Operational Experience, this conference
- [4] B. Szeless, F. Calvone, F. Rodriguez-Mateos, Development of Industrially Produced Composite Quench Heaters..., 16th.ICMC., Kitakyushu, Japan, May 1996
- [5] L. Coull, D. Hagedorn, Radiation Resistant Quench Protection Diodes for the LHC, ICMC, Albuquerque, USA, July 1993
- [6] D. Hagedorn, L. Coull, CERN Internal Note AT-MA-94-93, February 1994
- [7] F.Rodriguez-Mateos et al., Electrical Performance of a String..., MT14, Tampere, Finland, June 1995
- [8] A. Bezaguet et al., Cryogenic Operation and Testing of the Extended Prototype Magnet String, 16th.ICMC, Kitakyushu, Japan, May 1996