

Magnetic Components for DAΦNE

H. Hsieh, M. Modena, C. Sanelli, S. Vescovi
 INFN Laboratori Nazionali di Frascati
 C.P. 13 - 00044 Frascati (Roma) - Italy

Abstract

An overview of the magnetic components needed for DAΦNE project is given. The design parameters, engineering realization philosophy, construction approaches and the magnetic measurement methods will be described.

1. INTRODUCTION

INFN-Frascati National Laboratory is currently designing and constructing A 510 MEV electron positron colliding facilities. Figure 1 shows the birds-eye view of the facilities. It is a fully funded project with anticipated construction period of five years. The new facilities will be installed in the existing buildings and tunnels, there are some modifications have to be carried out prior to installation. The removal and storage of old radioactive equipment are very difficult tasks in this space limited campus. The project consists of two storage rings, accumulator, electron positron linac and approximately 200 meters of transfer lines. There are vast numbers of magnets of various types are required for this facilities. Due to lack of in-house manpower, it is anticipated that industrial collaboration will be heavily sought during the course of construction. This paper merely deals with magnetic components in general terms, many special magnets are presented elsewhere in this conference.

2. GENERAL CONSIDERATION

The DAΦNE has an on energy injection system, therefore, ramping of the magnetic components is not the machine function requirement. However, the stringent requirement of field strength uniformity of the storage ring components in the same circuit and reasonably large quantity of identical components warrant the laminated type construction.

The storage ring lattice requires both sector like and parallel end dipole magnets distributed in the machine. The magnet cross sections are distinctively difference between these two type of construction, a pseudo sector like magnet is being contemplated by the project staff. it is essentially a parallel end magnet with pole region machined orthogonal to the beam trajectory. It is obvious that this type of construction enables us to have only one kind of dipole lamination, the fabrication will also be simplified.

The width of the storage ring chamber is in the order of half meter, DAΦNE is a low energy high beam current storage ring, the vacuum quality is one of the important considerations to the performance of the machine. Synchrotron radiation will be absorbed at few discreet locations downstream of either bend magnets or wigglers where appropriate copper absorbers and large pumps can be installed. The chamber will only functioned as a vacuum enclosure capable of resisting atmospheric pressure. The multipoles in the arc sections of

the storage ring will have sufficient horizontal aperture to accommodate this wide chamber. We have chosen conventional multipole configuration, with return yokes passing through the midplane of the magnet, for our multipoles in this region. It is our belief that a better quality with comparable component cost can be realized by adopting this option.

The requirements of orbit correctors are very weak, they are in the order of 1-2 mrad. There are horizontal correctors incorporated into storage ring benders, those at other locations are of lump type. There will be no correctors incorporated into either quadrupoles or sextupoles, the undesirable effects due to this type corrector scheme will become bothersome to the machine, one should result to this type approach when the longitudinal space is at premium. All the corrector yoke will be made of 0.3 mm transformer grade steel to achieve faster response.

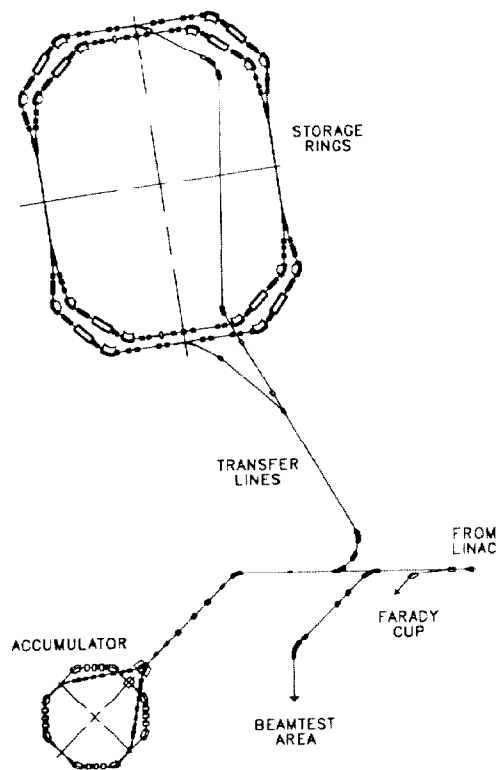

Figure 1. DAΦNE Birds-eye View

The dipoles will be supported on the reinforced concrete pillars to gain better stability and to isolate usual low frequency mechanical vibration transmitted through the ground floor. Multipoles and other components in the same straight

section will be supported on a common rigid girder, either made of meehanite casting or a properly stress relieved welded steel structure. The alignment of these components on the girder will be carried out in the assembly shop so that the placements in the machine will be greatly simplified. The multipoles will have the provision for adjustments individually in the ring should it be found desirable during the course of commissioning.

The alignment of the machine components is relatively simpler to compare with that of large machines. Both accumulator and storage rings are housed in separate open hall, lines of sight will not be obscured. The alignment accuracies are 0.2 mm transverse and vertical; 0.25 mrad. rotational. The alignment instruments for angles and levels will be conventional optical devices and the distance measurements will be done by utilizing Distinvar and invar wires. The survey network, which determines the correct positional relationship between injector system and the storage rings, will be more complicated to establish due to the existing building walls and tunnels.

There are approximately 400 total magnetic components of various type needed for the project. We have made large effort to minimize the number of different variety of the same type magnets so that the construction cost and schedule can be reduced. Most of the magnets are of conventional type. This paper will only describe few of those more interesting components.

3. PSEUDO SECTOR LIKE DIPOLE

3.1 Configuration

Figure 2. shows the preliminary design of pseudo sector like dipole for the storage rings, it is essentially a parallel end magnet with the end pole area machined orthogonal to the trajectory. The yoke is made of extra low carbon steel sheet of 1.5 mm thick, with the requirement of machining, the end portion has to be glued. The whole assembly will have appropriate solid steel straps and stainless steel end plates welded together to form a self supporting rigid body. The coils are made of copper hollow conductors with low current density of 2.2 A/mm².

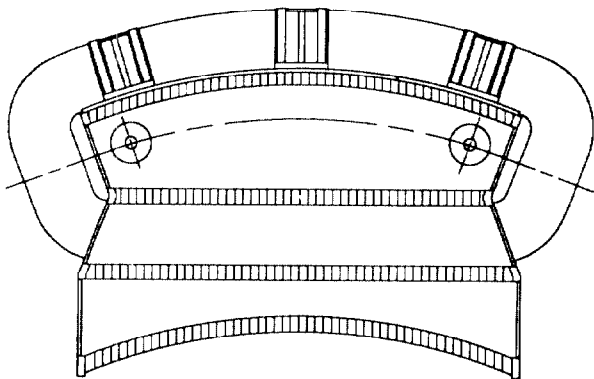

Figure 2. Pseudo Sector Like Dipole

Trim coil packages are part of the magnet to provide horizontal orbit correction and field integral adjustments. There will be three fiducial marks on top of the magnet for alignment purposes. The total assembly weighs six tons, it is supported on kinematic mounts which will be mounted on reinforced concrete pillar to achieve the proper beam height of 1,200 mm.

3.2 Magnetic calculation

A preliminary three dimensional magnetic calculation has been carried out to assess the validity of the engineering approach. Figure 3 shows the field plots at center and end of the magnet. The results of this preliminary investigation indicate that it is possible to have this type of design. We will proceed with more detailed studies in regarding to the higher harmonic contents and ampereturn differential between this magnet and true parallel end dipole which is part of the same circuit. Pole profile optimization will also be carried out to enhance the field quality or to reduce the physical size of the magnet.

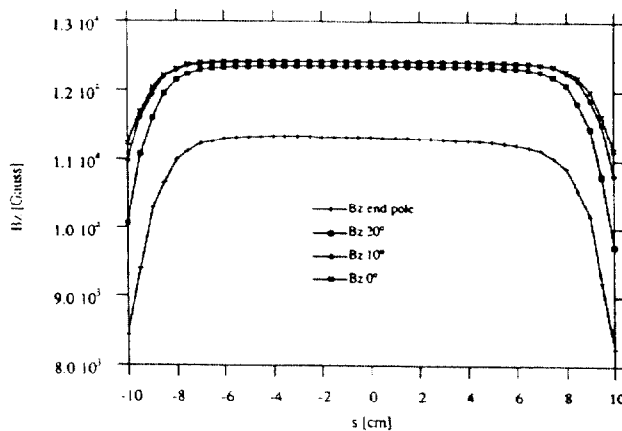

Figure 3. Pseudo Sector Like Dipole Field

4. ACCUMULATOR DIPOLE

4.1 Configuration

The dipole for the accumulator ring is of solid steel, combined function "H" type magnet. Nominal field is 1.55 Tesla with field index of 0.5. The magnet gap along the iso-magnetic line is 42 mm. There are total of eight such magnets required for the machine. The total length of dipole is therefore only in the order of seven meters, with such a small quantity, we have decided to make the yoke out of solid steel. A careful quality assurance program will be instituted to guarantee the uniform magnetic performance of all the magnets. There is no corrector windings incorporated into this dipole, the compensation of the field integral will be accomplished by shunting resistors. Figure 4.1 shows the cross section of this magnet. The yoke is made up with six pieces machined steel, the coils are conventional copper hollow conductors with current density of 4.5 A/mm².

The higher current density is the result of limited circumference of this machine. The alignment fiducials and supporting approach are similar to that of storage dipoles.

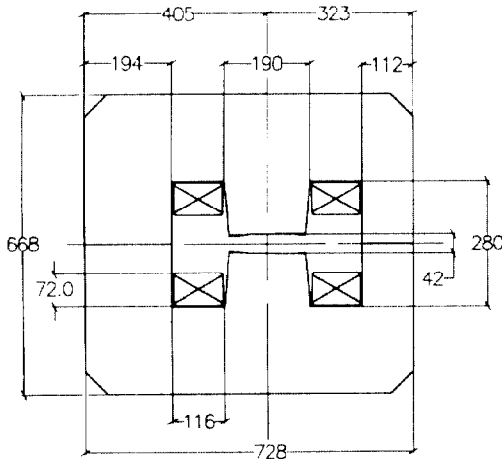

Figure 4. Accumulator Dipole

4.2 Magnetic Calculation

Magnetic calculation has been carried out with POISSON code using circular coordinates. Figure 2 shows the field plot radially. The three dimensional calculation will be done in the near future.

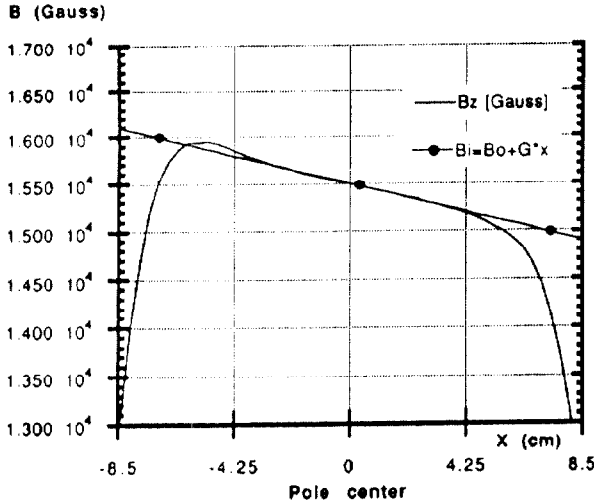

Figure 5. Accumulator Dipole Field

5. MAGNETIC MEASUREMENT

An old experimental hall, 24.5 * 12 m² in area has been completely refurbished to provide a clean and air-conditioned environment for magnetic measurement purposes. The magnetic measurements of prototype magnets for splitter and septum will take place before this summer. Due to very small scanning area inside the gaps of these magnets, a Hall probe (Group 3 Digital Hall Effect Teslameter by Danfysik) will be used. The Hall probe will be placed on the 'nose' of the x-y-z translator which has a 20 micron positional reproducibility. Different Hall probes with the same instrument will be used for different type of magnets. The reading precision is guaranteed to be $\pm 1 * 10^{-4}$.

Quadrupoles and sextupoles magnetic measurement and field characterization will be carried out by means of the Multipole Magnet Measurement System model. 692 of Danfysik. With this system we shall measure all the quadrupoles and sextupoles of DAΦNE facilities. The system is based on well experienced rotating coil technology which will give directly the higher harmonic contents of the multipole under examination. In addition, the alignment of the magnet prior to measurement is automatically performed by the system. The fiducialization of the magnet will be performed after the completion of the measurement by the same system. We expect to be able to characterized two-four magnets a day. Different rotating coils will be used due to both the different bore apertures and multipole strengths. The system meets the following specifications:

- Relative accuracy of integrated main harmonic $\pm 3 * 10^{-4}$
- Accuracy of ratio between integrated field of a multipole component and the main component $\pm 3 * 10^{-4}$
- Fiducialization with respect to magnetic central axis to within $\pm 30 \mu\text{m}$.

We are currently considering different options for our dipole measurements, no final decision has been made yet. The approaches under consideration are Hall probe scanning; movable integral coil; or fixed coil with field ramped. The measurements will be carried out with respect to a reference magnet. For the wigglers, we shall proceed with integral measurements on a full scale prototype, to determine the correct end poles and clamps shape to vanish the field integral. This will be accomplished by using an existing device based on 3 m long rotating coil that can be radially translated.