

# Use of Accelerators for Environmental Protection

Marian Pachan  
Soltan Institute for Nuclear Studies  
Świerk Poland

## Abstract

Accelerator supported technological processes can be useful in reduction or elimination of environment's pollution of diverse origin. Some representative examples of such technologies are reviewed and beam parameters matched to particular processes evaluated. Development of purpose addressed accelerators is also briefly presented.

## 1. INTRODUCTION

Harmful effects of environment's pollution became a worldwide problem. Pollutive agents are mostly of industrial origin, but some other factors, e.g. insect pests or foodborne diseases can be frequently considered as dangerous for environment. Distribution and intensity of contamination sources is of course not uniform, nevertheless numerous pollutants can propagate through long distances and contribute to global scale endangering. Due to these facts, environmental protection attracts common attention, and all possible ways to improve the situation are considered. First of all it is desirable to suppress or diminish generation of pollutive substances in industrial or other type activities, by introducing new technologies, new materials and better handling of products before and after use.

As in any other troublesome phenomena, there does not exist an universal remedy, but it is advisably to apply various feasible and efficient procedures related to the given task.

Accelerators as sources of penetrating particle beams, can be foundation for new technological procedures where the beam reacting with the matter, can create or decompose some compounds, giving in result reduction of pollutants' emission. Accelerator based technologies can be separated processes or connected with combined treatment systems. Various types of pollutants are penetrating with different concentrations into all parts of surroundings - air, waters, soil, plants and animals, food and feed, solid and liquid wastes and sludges.

Most important harmful agents are:

- in atmosphere: combustion flue gases, aerosol gases, evaporating solvents
- in waters, soil, and sludges: components of chemical fertilizers, pathogenic organisms and bacteria, polyphenols, pesticides, herbicides, organo-metallic constituents, chloro-

nated hydrocarbons

- agricultural products: pathogens and bacteria (e.g. salmonella, trichinosis) fungi, moulds, and mycotoxins, insect pests.

During recent ten years important efforts were done in numerous centres around the world, to develop technologies and equipment for radiation methods of reduction in pollutants' penetration into environment.

Most frequently used beam sources are electron accelerators in two energy ranges - 0.2 to 1 MeV, 2 to 10 MeV, and elevated beam power.

## 2. COMBUSTION FLUE GAS TREATMENT

Typical thermal power plants, which apart from nuclear power stations, are main sources of electric energy are fired with coal, heavy oil or gas. All these fuels, but mostly coal, are giving in burning process a lot of outlet substances like dusts and many gas compounds, which are ejected through the chimney and mixed with surrounding air. Dusts can be efficiently removed by electrostatic filters, but the aggressive gas components like  $\text{SO}_2$  and  $\text{NO}_x$  are emitted and penetrate into atmosphere. Due to quantity of power plants and the volume of flue gases, the amounts of sulphurdioxide and nitrogenoxides emitted are of order of millions tons, what leads to formation of acid rains and other disastrous for the nature effects. Conventional systems of Wet Scrubber for  $\text{SO}_2$  removal, and separated Selectic Catalytic Reaction for  $\text{NO}_x$  removal have been developed and are installed in many plants. But the handling of wastes is rather complicated and troublesome. In parallel to these methods, electron beam technologies have been studied in several countries (e.g. Germany, Japan, U.S. and recently in Poland) at the beginning on laboratory scale and in subsequence on pilot installations scale.

Electron beam process is a dry-scrubbing procedure, which simultaneously removes  $\text{SO}_2$  and  $\text{NO}_x$ . Interaction of high energy electrons leads to ionization and excitation of main gas components ( $\text{N}_2$ ,  $\text{H}_2\text{O}$ ,  $\text{CO}_2$ ,  $\text{O}_2$ ) what produces active radicals which react with  $\text{SO}_2$  and  $\text{NO}_x$  molecules to form their respective acids. The treatment process consists of adding ammonia to the flue gas before irradiation. In the presence of  $\text{NH}_3$ , the newly created acids are converted to ammonium sulphate  $(\text{NH}_4)_2\text{SO}_4$ , and ammonium sulphate-nitrate  $(\text{NH}_4)_2\text{SO}_4 \cdot 2\text{NHNO}_3$ . In that way pollutive agents can be transformed into components of agricultural

fertilizers or some other useful products. Efficacy of the process is estimated for 95% for  $\text{SO}_2$  and 80% for  $\text{NO}_x$ . The basic problems connected with broader implementation of electron beam technology are design and installation of appropriate accelerators, and economic relations. As indicate the examples of existing or planned pilot installations, the necessary beam power constitutes few percent of produced electric energy. At present in existing plants accelerators have the energy in the range 0.2 - 0.8 MeV, and power in one radiation head 50 - 100 kW.

To equip high-power plants with installation handling total flue gas amount, big number of powerful accelerators is required. General tendency is to design accelerators about 1 MeV and 1 MW in electron beam. Economical analyses of investment and operation costs indicate that at present state of technology E.B. method is cheaper up to about 120 000  $\text{Nm}^3/\text{h}$  flue-gas volume. Above 180 000  $\text{Nm}^3/\text{h}$  conventional methods become more economic. Further experimental works in new installations can bring new data and change the relations.

### 3. HARDENING OF VARNISHES AND DRYING OF PRINTING-INKS

Conventional types of varnishes and inks for coatings of wood-panels, furniture elements, metals, offset printing etc. are using various types of solvents, which in the drying process are evaporated, and in many cases are penetrating to the atmosphere. They bring their contribution to contamination of the environment.

The use of electron beam can induce rapid conversion of especially formulated reactive liquids into solids.

In this technology often called a cold oven, no solvent are used, and emission of pollutive agents eliminated. Due to thickness of typical coatings, the required energy of accelerated electrons is in the range 150 - 300 keV. For necessary throughput of processing in the industrial type plants, the beam power is of the order 100 - 200 kW. At

present about two hundred installations for electron beam curing of varnishes exist.

An obstacle for more broad implantation was the problem of installation and maintenance costs.

With improvements in accelerators' technology, the number of installations should grow in next years.

## 4. TREATMENT OF WATERS AND SLUDGES

### 4.1. Waters

In most countries, potable and effluent waters' pollution is at present major problem in environmental protection.

In spite of increase of purification plants' quantity, total amount of polluted water in global circulation is growing-up.

Conventional technologies of water treatment are not sufficient. In frequently applied chemical methods, for each ton of processed water, several kilograms of residual effluent increase pollution problem. Biological methods are slow, expensive and sensitive to chemical pollution. In addition there is difficult to eliminate seeds, pathogenic germs closed in matrices of mud, spores, and encysted forms. Thermal methods are energy consuming and cannot be used on industrial scale.

In many cases ionizing radiation treatment can be an effective solution, or supporting supplement. Numerous studies have shown that the exposure of water to electron beam does not modify its basic chemical constitution and biological properties[7]. In experimental works was indicated, that pollutants most frequently existing in drinking water like perchloroethylene and trichloroethylene were efficiently decomposed or reduced at the doses 100 - 500 Gy [9]. Very effective was also the combined treatment radiation/ozonation. In such processing, radiation doses required were much lower and the synergic effect is present. Also at combined treatment formation of nitrite, occurring at radiation alone is eliminated.

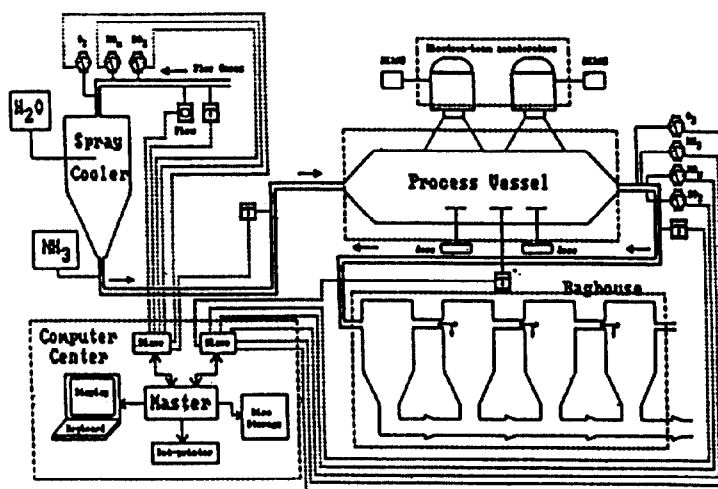

Typical arrangement of pilot installation for flue gas processing

For electron beam processing on municipal scale, the energy of accelerated electrons should be sufficient to penetrate into a layer thick enough to transmit necessary volume of drinking water. For a given energy this layer can be increased by turbulent mixing of flowing stream [7]. Typical energy can be estimated for 4 to 10 MeV, and beam power in dependence from flow rate e.g. 50 - 200 kW.

Electron beam treatment proved also to be effective in the events of contamination of artesian potable-water sources by penetration of pesticides and herbicides used in agriculture (e.g. atrazine, parathion). Complete degradation of these compounds were measured at low doses about 0.5 - 1 Mrad [6].

Experimental investigations on waste water irradiation for its disinfection and conditioning have been carried in numerous centres around the world on laboratory and pilot installation scale. The collected data indicate the usefulness of electron beam treatment for decomposition of pollutive agents in water. An illustrative example, is the research done in Italy (ENEA) [12], on electron beam induced decomposition of polyphenolic substances in waste water-effluent from olive-crushing mills. These compounds are inhibitors of microbial biodegradation in lagooning-type conditioning of water. Taking into account quantities of waste water in this industry-estimated for 3-5 millions tons per year, the scale of problem is quite serious. Using 5 MeV electrons, degradation of phenols was measured for various doses and phenol concentrations. The results are promising and confirm that electron accelerators can be in best way useful in technology of waste water processing.

#### 4.2. Sludges and solid wastes

Municipal sewage sludges can be, after composting process, a valuable component of fertilizers. Similarly can be used sludges e.g. from big cattle-farms, and some kind of sludges can serve as substratum for growing of selected varieties of yeasts, serving subsequently as additive to animal feed. Taking into account total quantities of produced sludges, their reuse constitutes an important factor of recycling in agriculture.

The limitations in these procedures are:

- content of organic and inorganic toxic substances, which contaminate the soil and plants, and may negatively influence the growth of animals and plants
- existence of pathogenic organisms which can be hazardous disease-transmitting factor, penetrating to plants, animals and men.

Therefore it is necessary to apply a process deteriorating toxic substances and destroying pathogens.

As conventional processing, thermal treatment is frequently used, but it is rather energy consuming and expensive system.

Radiation can be effectively used for that purpose, giving in a cold processing, high-quality and safe product.

Several big-scale experimental stations have been constructed in various countries, using either gamma radiation from nuclide sources, or electron beam from accelerators. The results of long-term operation confirm the usefulness of radiation treatment, and for high throughput rates are in favour of high-power accelerators. To handle enough thick layer of irradiated material with good dose uniformity, the energies of electrons lie in the range 2 - 10 MeV, and beam powers for economically competitive installations 50 - 200 kW.

Electron beam treatment has been also tested for upgrading of usability and sterilization of solid organic wastes. Generation and collection of such wastes, mostly in municipal centres is estimated in average countries for millions of tons, being one of major problems in environmental protection.

#### 5. FOODBORNE DISEASES

Some kind of dangerous diseases transmitted through bacteria, pathogenic organisms, insects etc., contained in agricultural products, can propagate easily in broad scale and become a serious risk for human environment.

Food preservation by irradiation is always a controversial method in spite of enormous experimental research completed in this field.

It is mostly connected with public acceptance restrains, influenced by general mistrust to nuclear techniques, which arose after Chernobyl accident. But some types of treatment improve hygienic quality of agricultural products and help to eliminate foodborne diseases.

As such are recommended by World Health Organisation. Fundamental of them are:

- irradiation of animal feed to control the pathogenic microorganisms
- disinsection of grain infested by various forms of insects
- quarantine treatment of contaminated products (fruits, spices, etc.)

Good example of feed treatment is irradiation of poultry feed. In big poultry farms large number of birds are maintained together. Under these conditions disease prevention is a critical concern. The feed route is a main avenue for penetration of disease organisms. Damage caused by insects and poisoning enteropathogenic and enterotoxigenic microorganisms can be disastrous.

For prevention purposes, as conventional procedure, large quantities of fumigants, antibiotics and other chemical additives are widely used in feedstuffs. It has been noted that chemical treatment of feeds has had some toxic effects on animal and human, and has caused environmental pollution.

In contrast, radiation treatment of feed gives safety in animal nutrition. Elimination of pathogenic and toxinogenic microorganisms from feed can aid in breaking the cycle of infection from feed to poultry and to man.

This example is representative also for other types of

processing of contaminated products.

According to rules of Codex Standard International, for treatment of agricultural products, following radiation sources are accepted:

- gamma radiation of cobalt-60 (1.17 MeV and 1.33 MeV)
- gamma radiation of cesium-137 (0.66 MeV)
- X-rays generated by 5 MeV<sub>max</sub> electrons
- electron beams of energy 10 MeV<sub>max</sub>

Absorbed doses required to stop development of insect eggs and larvae are of the order of 1 kGy.

Yeasts and moulds are reduced at an absorbed dose 5 kGy. Doses of 6 kGy are effective in eliminating salmonellae and fungi.

For radiation treatment of feeds, grain, spices etc., the use of electron beam is preferable. Accelerator with a beam-power about 20 kW can irradiate 200-300 ton/h of grain, at the dose 0.5-1 kGy.

For equipment of industrial scale plant, and operation with electron beam, or secondary X-ray beam, 10 MeV accelerator (5 MeV for X-ray) with beam power 20 - 100 kW is suitable.

## 6. OTHER APPLICATIONS

To the above mentioned examples of accelerators' applications in environmental preservation, many others can be added, like:

- use of electron and ion beams in creation of new, more nature-friendly materials
- use of electron and ion beams in analysis of material composition, as monitoring of character and intensity of pollution
- use of intense proton beam for transmutation of nuclear wastes (Los Alamos project)

Not unimportant is also the fact, that use of accelerators e.g. for radiotherapy, radiography etc., reduces the number of long-lived nuclide sources used for the same purpose, and in effect eliminates environmental menace by high activity sources.

Nevertheless, most important and most effective task for nearest years, is design and implementation of purpose addressed accelerators in major processes responsible for environmental pollution.

## 7. DIRECTIONS IN ACCELERATORS' DEVELOPMENT

Basic research and experimental investigations in application of electron beam processing for environmental protection, have been long time conducted in many centres, initially on laboratory scale and later in pilot installations. For both these levels, there existed or were adapted suitable accelerators, with parameters meeting the requirements of the given process.

The next step in particular technologies, and in accelerators' design leads toward closer approach to full-scale operation, when all technical and economical factors should be verified in real conditions.

In low energy accelerators (0.4 to 1.0 MeV), addressed mainly for flue gas treatment, d.c. type with high energy conversion efficiency should predominate. A preferable high-voltage source is multiphase, elevated frequency transformer-rectifier system with output power 1-10 MW supplying several separated radiation heads. Main problem in accelerating system is the transport of high space charge beam without losses, as well as beam transition from vacuum volume to high pressure gas chamber.

Several projects of similar type are in realization. E.g. at Swierk the design and construction of 0.8 MeV, 1 MW, four head system started last year.

In the energy range 2-10 MeV, there are several promising directions in designing of advanced, high-power accelerators.

Proposed solutions are:

- linear standing-wave accelerator in S or L frequency band
- separated resonator modular structure in the band of 200-300 MHz
- multipassage resonator structure (Rhodotron)
- linear induction accelerator

Well advanced is AECL project [11] of hybrid irradiator designed to reach beam power up to 500 kW, operating either with output electron beam, or with conversion for X-rays.

It uses on-axis coupled standing-wave structure, which is supplied from klystron working in long pulse mode.

Preliminary design study of high-power standing wave structure in L band has been also accomplished in Soltan Institute at Swierk. In Soltan Institute, modular system with separated resonators and external accelerating field phase control has been designed and model measurements conducted.

It is calculated for heavy duty operation, and with existing r.f. sources in 200-300 MHz frequency band can reach the output beam power in the range 50-100 kW. Modular system can be easily matched to various processing types.

Multipassage coaxial resonator system (Rhodotron) [13], reported on last EPAC, after operation experience can be an interesting, compact, industrial machine.

Well advanced, and promising for the future is linear induction accelerator [18], which at high repetition rate of short pulses can achieve high average beam power. Its modular inductor system makes it easy to arrange the accelerator's configuration for required parameters. Localization of field exciting inductors outside the evacuated beam transporting tube facilitates vacuum requirements. All these advantages indicate, that this type can be in several years very competitive solution, for accelerators up to 10 MeV, with beam power reaching the megawatt range.

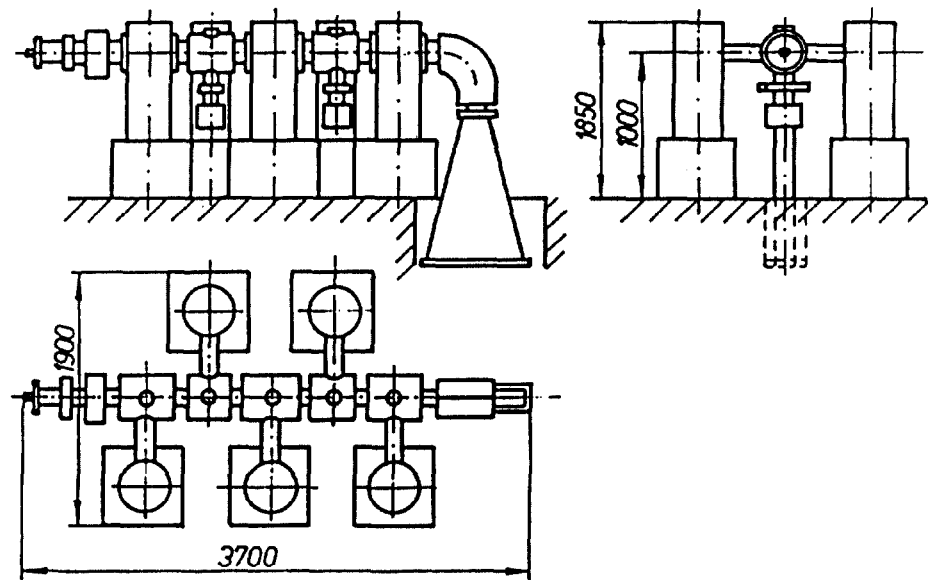

*Example of modular-accelerator arrangement*

#### 8. REFERENCES

- [ 1 ] S.Jordan, Flue gas cleaning by irradiation with fast electrons, *Radiation Phys.and Chem.* Vol.35, 1990
- [ 2 ] N.Frank et al. The electron-beam FGT process, *Radiation Phys.and Chem.* Vol.35, 1990
- [ 3 ] K.H.Platzer et al. Flue gas cleaning by the electron-beam process, *Radiation Phys.and Chem.* Vol.35, 1990
- [ 4 ] A.Chmielewski et.al. *Monitoring and control system for pilot SO<sub>2</sub> and NO<sub>x</sub> removing installation-Kawęczyn*, Soltan Institute for Nuclear Studies, Annual Report, 1990
- [ 5 ] Ebara Corporation, Fujisawa pilot for electron-beam flue gas treatment test, 1991
- [ 6 ] N.Getoff, Decomposition of biological resistant pollutants in water by irradiation
- [ 7 ] Cl.Gallien et.al. A CGR/MeV study on high energy electron beams for the treatment of waters and sludges, CGR/MeV Rep. ITC.77.0058/A-CL.CLG/AM, 1977
- [ 8 ] T.Miyata et al. High energy electron disinfection of sewage wastewater on flow system, *Radiation Phys.and Chem.* Vol.35, 1990
- [ 9 ] P.Gehringer et al. Removal of chlorinated ethylens from drinking water by radiation treatment, *Radiation Phys.and Chem.* Vol.35, 1990
- [ 10 ] M.R.Cleland et al. Electron beam process design for the treatment of wastes, *Radiation Phys.and Chem.* Vol.24, 1984
- [ 11 ] J.McKeown et al. An intense radiation source *Nucl. Instr. Meth. B* 10/11, 1985
- [ 12 ] U.Bizzarri et al. Electron accelerators at the EIGNE Centre at Frascati *Nucl.Instr.Meth. B*50, 1990
- [ 13 ] A.Nguyen et al. Rhodotron first operation *Proc.of EPAC 90*, Nice
- [ 14 ] IAEA Code of good irradiation practice for the control of pathogenic microorganisms in poultry feeds, *International Consultative Group on Food Irradiation*, 1991
- [ 15 ] WHO, Food irradiation-a technique for preserving and improving the safety of food, *World Health Organisation*, Geneva, 1989
- [ 16 ] S.Ignatowicz et al. Use of irradiation as quarantine treatment for agricultural products infested by mites and insects, *Radiation Phys.and Chem.* Vol.35, 1990
- [ 17 ] J.Sivinski et al. The role of linear accelerators in industry, *Nucl.Instr.Meth. B*10, 1985
- [ 18 ] M.C.Lagunas-Solar, Induction-linear accelerators for food processing with ionizing radiation, *Nucl.Inst. Meth. B*10, 1985.