

RESEARCH AND APPLIED NEUTRON GENERATORS

G.G. Voronin, A.S. Ivanov, M.P. Svinjin
Efremov Research Institute of Electrical and Physical Apparatus
189631, Leningrad, USSR

The neutron generators with a neutron yield $2-5 \times 10^{11}$ n/s for neutron-activation analysis and the ones with a neutron yield 10^{12} n/s and more, aimed mainly for researches are designed and manufactured in Efremov Institute (NIIEFA). The generators are equipped with the electromagnetic mass-separators to exclude the molecular components from the beam. The hydrogen ions beam with the current up to 100 mA at energies 250-300 keV is obtained on the experimental accelerator.

Large efforts made to design powerful neutron generators are explained mainly by the great demand for intensive neutron fluxes to investigate radiation resistance of fusion reactor materials and to carry out researches in the neutron physics. Of special interest are neutron generators operating both in continuous and pulse regimes. Quite a number of researches, such as measurements of microscopic cross-sections and integral experiments at small interaction cross-sections, may be carried out with their help. The development of activation analysis is under way, where the application of intensive neutron fluxes allows to increase the sensitivity and accuracy of methods.

Generators with a neutron yield $1-5 \times 10^{11}$ n/s, which may be applied for neutron-activation analysis, and the ones with a neutron yield 10^{12} n/s and more, intended mainly for scientific researches, are designed and manufactured in NIIEFA over a long period of time. After putting the generators with a rotating target, which provided a yield of 10^{12} n/s, in operation (Ref. 1), the works on generation and shaping of the beams of atomic deuterium ions with a few tens of milliamps were continued.

A number of ion sources of duoplasmatron type to generate a deuterium ion beam with a current of 5 mA, 30 mA and 100 mA has been designed for neutron generators. A duoplasmatron remains one of the most commonly used sources in neutron generators mainly due to its high gaseous efficiency and, besides, it provides high fraction of atomic ions. It is achieved by generating high discharge density in the field of the emission hole, this in its turn results in the development of an anode block composed of tungsten and copper with effective cooling. The content of atomic component in the designed sources amounts to 60% at a beam current of 5 mA and 70% at a beam current of more than 20 mA.

One of the main problem while designing a high current duoplasmatron is beam shaping with parameters suitable for further acceleration and transport to the target.

In the result of numerical and experimental studies the parameters of extraction region were optimized and the data for optimization calculations for ion-optical system of accelerators were obtained.

An ion-optical system for generation of a beam with a crossover at a distance up to 2 m from an acceleration tube while changing the beam current in a wide range, was designed while applying as the main focusing element the lens formed by an acceleration tube inlet and a focusing electrode with regulated potential.

The acceleration tube with the ion source of the high-current accelerator, where a beam of hydrogen ions with a current up to 100 mA has been generated at 250-300 keV energy, is shown in Fig. 1 (Ref. 2).

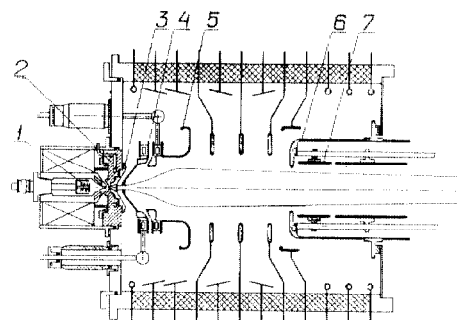

Fig. 1. The acceleration tube with the ion source
1-cathode; 2-anode; 3-expansion cup;
4-extracting electrode; 5-focusing
electrode; 6-accelerating electrode;
7-bias electron trap

Electrode configuration and potential distribution over electrodes were selected by an optimization computing program. Fig. 2 shows ion beam envelopes calculated at different values of beam current and potential on the focusing electrode.

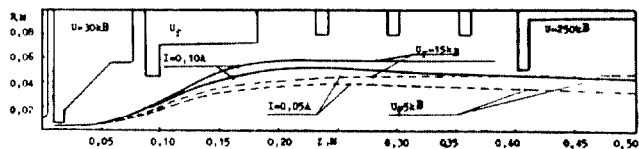

Fig. 2. Beam envelopes in the acceleration tube

A number of acceleration tubes for different beam parameters has been designed for neutron generators. These tubes structurally differ in dimensions and the way of potential distribution in the accelerating gap. They are glued from porcelain insulators and stainless steel disks, on which the electrodes of the ion-optic system are installed. Now we begin using in the generators the acceleration tubes made by the method of thermal-diffusion welding.

One of the most complicated and critical unit of an intensive generator of D-T neutrons is the target

operate with a more powerful ion beam. Differential pumping provides uniform pressing of the seal ring and reduces the leakage into the target assembly.

The experimental works carried out allowed to design a number of generators with yield of 10^{11} - 10^{12} n/s (Ref.3). All generators are provided with magnetic mass-separators of an accelerated ion beam to increase considerably the life time of titanium-tritium targets. The highvacuum pumping generator systems are designed on the basis of titanium sputter-ion pumps.

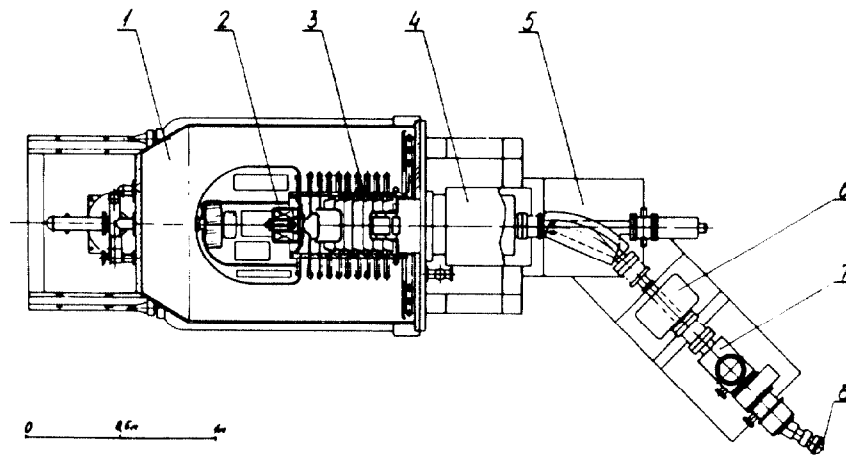

Fig. 3. The principal scheme of NGP-11 generator
1-tank; 2-ion source; 3-acceleration tube; 4-vacuum pump;
5-mass-separator; 6-quadrupole lens; 7-beamstopper; 8-target

assembly. To operate with a beam of various power four modifications of target assemblies were designed. Two of them are meant for operation in generators with yield up to 2×10^{11} n/s and 5×10^{11} n/s, respectively. The titanium-tritium targets 45 mm and 90 mm in diameter are displaced in a circular manner relative to an ion beam by a bellows drive. The bellows provides reliable tightness of the device, but limits the speed of circular displacement of the target (down to 100 rpm).

The target assembly with a rotating target 90 mm in diameter runs during several years in the generator with a yield of 10^{12} n/s, providing the operating thermal regime of the target at a rotation speed of 1000 rpm. But comparatively small area of the active layer of the target does not provide long-term operation of the generator at high neutron yield. The target assembly with targets 230 mm in diameter, rotating with a speed up to 1000 rpm permits to considerably increase the duration of continuous generator operation and to provide the possibility to

The NGP-11 neutron generators, its principal scheme is shown in Fig. 3, has a neutron yield of 2×10^{11} n/s with the half-life time of the target about 100 hours.

The generator accelerator permits to obtain atomic ions beam up to 2 mA on the target at an ion energy of 150 keV. The ion source and acceleration tube are in the tank, filled by an insulating gas. High voltage and supply to the ion source are delivered by a multicore high-voltage cable from the closed blocks filled with condenser oil. The isolation of high-voltage accelerator structure from the environment allows to provide more reliable accelerator operation. At present modified generator is being designed, which will provide a neutron yield of 5×10^{11} n/s and where a high-voltage supply and power supply systems of the ion source are placed together with the acceleration tube in one tank.

The NG-12 neutron generator, the accelerator of which has undergone complex tests, is designed for a neutron yield of $1-2 \times 10^{12}$ n/s.

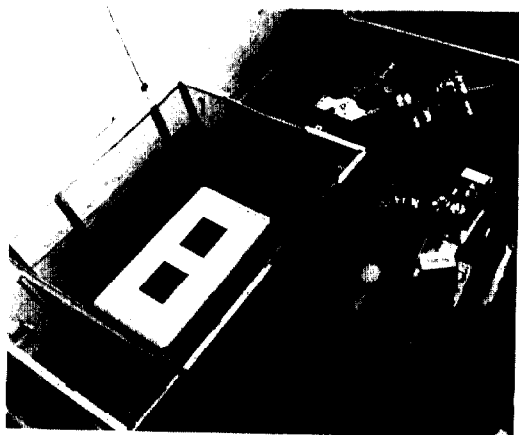

Fig. 4. The general view of the NG-12 accelerator

The high-voltage accelerator structure is of an open design. Supply voltage to the ion source is delivered by a high-voltage cable. The high-voltage rectifier and power supply unit of the ion source are installed in metal tanks with oil insulation.

The power supply systems of the ion source are located in the high-voltage terminal. The source parameters are controlled by optic fibre communication channels. High-voltage supply is located near the high-voltage terminal. Mass-separation of a beam is performed by the electromagnet with a bending angle of 45° . A beam is focused on the target by the doublet of electromagnetic quadrupole lenses. It is possible to bend a beam in three directions if we equip the generator with additional transport systems with target assemblies. The target 230 mm in diameter has a circular active layer 200 mm in the outer and 100 mm in the inner diameter. Besides rotary motion of the target the forward motion relative to a beam is provided for better usage of the active layer.

The equipment for pulse regime of the generator operation, which will be installed in one of the transport channels, is being designed. The system of beam interruption with the following bunching will permit to generate neutron pulses with a duration up to 1 ns, thus enlarging the field of generator applications.

Further works on neutron generators aim also at an increase in the neutron output in the continuous regime.

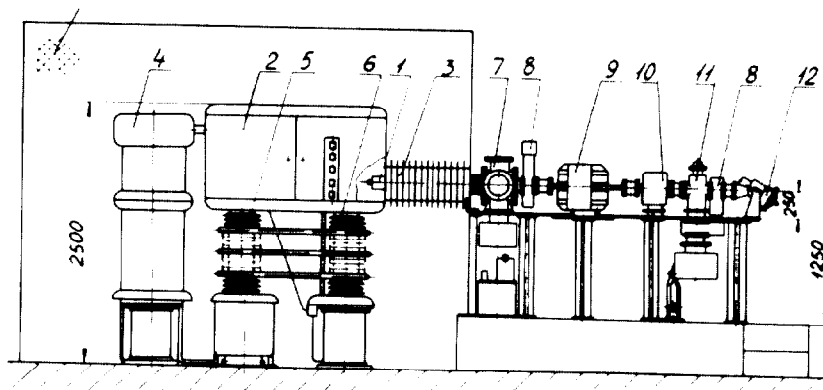

Fig. 5. The principal scheme of the NG-12-1 generator
1-ion source; 2-high-voltage terminal; 3-acceleration tube; 4-high-voltage source;
5-isolation transformer; 6-stabilizing divider; 7-vacuum chamber; 8-vacuum valve;
9-mass-separator; 10-quadrupole lens; 11-beamstopper; 12-target assembly

Fig. 5 shows the principal scheme of the NG-12-1 generator with a yield of $1-2 \times 10^{12} \text{ n/s}$. The accelerator permits to obtain the atomic ions beam with a current up to 10 mA and an energy of 250 keV.

References.

1. Voronin G.G. et al. *Atomnaya Energiya*, 1984, v. 57, p. 268
2. Voronin G.G. et al. Proc. of 10th All-Union Conference on charged particle accelerators, Dubna, 1986, v. 2, p. 109
3. Voronin G.G. et al. Proc. of 10th All-Union Conference on charged particle accelerators, Dubna, 1986, v. 2, p. 131