

**FIRST RESULTS OF THE 14.5 GHz GANIL ECR SOURCE
WITH THE C.W. AND THE PULSED OPERATION MODE**

M.P. Bourgarel, P. Sortais, P. Attal, M. Bisch, P.M. Cornen
P. Lehérissier, J.Y. Pacquet, J.P. Rataud, G. Schmiechen

GANIL - B.P. 5027 - F - 14021 CAEN CEDEX

Abstract : A 14.5 GHz ECR source has been designed and built at GANIL in order to improve the currents, mainly the heaviest ion beam intensities (Pb, U). We give the first results obtained with the C.W. operation used on the cyclotron machines, and those we can get with the pulsed operation mode which concerns Linacs and other machines.

Description

A new 14.5 GHz ECR source [1] has been designed and built at GANIL in order to improve the currents on the second injector cyclotron devoted to the GANIL modification (called O.A.I.), as already described [2] at this conference.

This source is founded on the following topics :

- to realize the best confinement, and to keep the mirror inside the hexapole,
- to reach twice the value of the resonant field (0.52/1.04T) in the injection zone as for the CAPRICE source, and to have the minimum value (about 0.8T) on the wall chamber located near the extraction zone.

Figure 1 shows the main parts of the source.

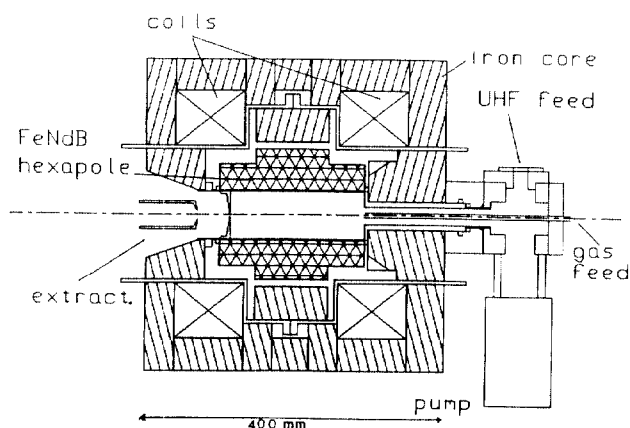

Figure 1 : Sketch of the 14.5 GHz GANIL ECR source

The relative positions of the coils and the hexapole are optimized in order to minimize the magnetized volume. The iron pieces near the axis allow to well-define the position of the maximum axial field (obtained with 45 kW).

The 1T hexapole is made of FeNdB permanent magnets (VACODYM 370). It is built with 3 slices embedded in an iron yoke.

The plasma chamber is a double wall chamber with the cooling between the two walls. So now it is not necessary to cool the hexapole magnets and then it avoids corrosion problems.

The source uses a co-axial line similar to the CAPRICE line, and the RF transmitter is operated with a 2 kW 14.5 GHz VARIAN klystron.

In order to separate functions, the high voltage insulator is around the hexapole and is not a part of cooling and vacuum system like in the CAPRICE source.

The cooling water comes into the source and goes out through the UHF cube as well as the gas, the pumping, the UHF power and metallic samples.

Results with the C.W. operation

Figure 2 shows the results of the 14.5 GHz source (curve b) obtained on the test bench (at 15 kV). We can compare these results to our CAPRICE $2w_{ce}$ 10 GHz source (curve a), which is in operation on the first injector cyclotron.

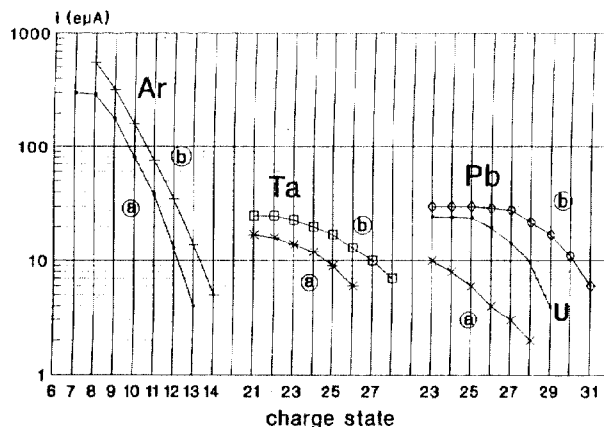

Figure 2 : Charge state distribution

In order to qualify the source and to make easier the comparison with the other sources, we show some results for Argon (up to the charge 14+) and for the heaviest ions (Pb and U).

Ar ⁸⁺	: 580 e μ A	with P _{HF}	550W
Ar ¹¹⁺	: 75 "	"	700 W
Ar ¹²⁺	: 37 "	"	"
Ar ¹⁴⁺	: 5.5 "	"	"
Pb ²⁵⁺	: 30 e μ A	"	1 kW
Pb ²⁸⁺	: 22 "	"	"
U ²⁵⁺	: 32 "	"	540 W
U ²⁷⁺	: 14 "	"	"

First results with the pulsed mode of operation

It was interesting to see if the good performances obtained with the C.W. operation, were also achieved with the pulsed operation mode.

Two possibilities are observed (figure 3) :

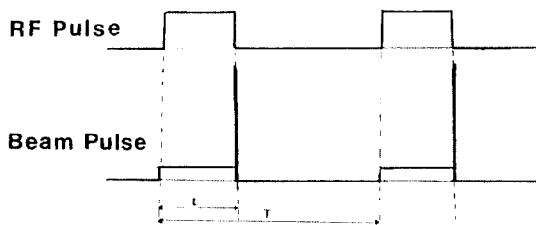

Figure 3 : Time structure of the beam

a) A beam pulse during the RF pulse :

The currents are multiplied by a factor of 1.5 to 2 as expected and the charge state distribution is slightly shifted toward the higher charges.

For example, with a duty-cycle value equal to 1/2 (to 1/3) and a repetition period equal to 100 ms (to 150 ms) a 30 e μ A Pb²⁸⁺ was optimized (instead of Pb²⁵⁺ with the C.W. mode).

b) A very short beam pulse (0.5 to 1 ms) at the end of the R.F. pulse, corresponding to the "afterglow" effect as described by Geller and Melin [3] :

the interruption of the heating of the electrons by the R.F. power causes a rapid diffusion of them, and consequently it causes a rapid deconfinement of the multicharged ions. So this implies an important flux through the wall of the chamber.

If the source parameters are then re-optimized on this current, the beam pulse during the R.F. pulse decreases and almost all the current is concentrated in the sharp peak at the end of the R.F. pulse, particularly for the multicharged ions.

Tests have been done with Argon and Lead (figure 4), and the following results are obtained :

	Intensities During the R.F. pulse	Intensities At the end of the R.F. pulse	V ext (kV)
Ar 11+	40 e μ A	200 e μ A	20
" 13+	8 "	50 "	"
" 14+	2 "	20 "	"
Pb 28+	8	75 "	15
	10	90 "	20
		100 "	23

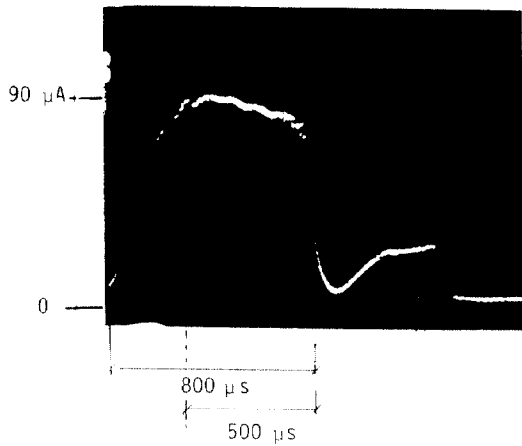
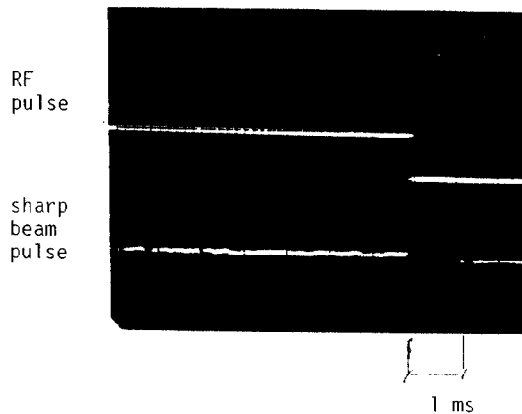
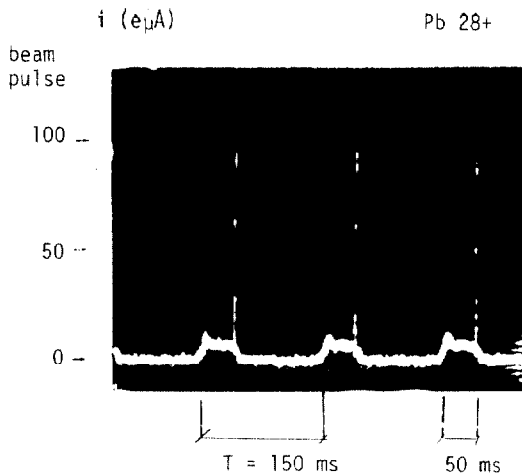

Figure 4

References :

[1] - P. SORTAIS, P. ATTAL, M. BISCH, M.P. BOURGAREL, P. LEHERISSIER, J.Y. PACQUET - ECRIS Development at GANIL -Proceedings of the Int. Conf. on IOn Sources - Berkeley - July 10-14 (1989) - pp. 288-290

[2] - CH. RICAUD, P. ATTAL, E. BARON, J. BONY, M.P. BOURGAREL, B. BRU, A. CHABERT, S. CHEL, F. DAUDIN, M. OZILLE, P. SORTAIS, R. VIENET - Status of the new high intensity injection system for GANIL This conference

[3] - G. MELIN and al - Grenoble ECRIS Status - Journal de Physique - Colloque C1, tome 50 - Janv. 1989