

# COMMISSIONING OF THE ACCEL 250 MEV PROTON CYCLOTRON

A.E. Geisler, J. Hottenbacher, H.-U. Klein, D. Krischel, H. Röcken,  
M. Schillo, T. Stephani, J.H. Timmer,  
Accel Instruments GmbH, Bergisch Gladbach, Germany

C. Baumgarten, now at PSI, Villigen, Switzerland

## Abstract

The ACCEL superconducting 250 MeV proton cyclotron at PSI/Switzerland is fully operational and in clinical use. The commissioning on site started in December 2004 whereas the commissioning of an identical system installed at RPTC/Germany begun only two month later. After conditioning of the RF system to a power of 120 kW first beam was extracted from both machines in April 2005. By the end of the same year the key specifications were met and the main design goals reached. During 2006 further refinements of the hardware setup and control system have been implemented. Automatic start-up routines and a phase feedback loop have been introduced to optimize the reliability and stability of beam operation. Since beginning of this year the PSI machine is in routine operation. The design of the compact machine, proposed by Henry Blosser and his team [1] and further developed and manufactured by ACCEL, proved to be very successful in operation with

low energy consumption, high energy and intensity output, high internal efficiency, low internal activation, reproducible beam properties and reliable operation. We report about details of the commissioning process, performance of the machines and the progress that has been made.

## INTRODUCTION

The ACCEL medical proton accelerator is a compact four sector AVF isochronous cyclotron featuring a superconducting main coil that excites a magnetic induction of 2.4 T in the center, an extraction radius of 815 mm and a weight of only 90 tons. The RF system operates at 72.8 MHz, which is the second harmonic of the beam orbital frequency. Our last status report [2] dealt with the design, manufacturing and first tests of ACCEL's superconducting 250 MeV proton cyclotrons and the subsequent hardware installations at the customers' premises at PSI/Switzerland and RPTC/Germany. Since then considerable progress has been made during commissioning of those machines which now fulfill all design goals. Selected key features are listed in Tab. 1.

Table 1: Key features of the ACCEL cyclotron.

<b>Iron Yoke</b>	
Outer Diameter	3.2 m
Height	1.6 m
Weight	90 tons
<b>Magnet</b>	
10:1 Monolithic Wire-In-Channel SC Type	
Operating Current	160 A
Induction at Coil	<4 T
Induction at Center	2.4 T
Stored Energy	2.5 MJ
<b>Cryogenic System</b>	
Heat Load std.	2 W
Heat Load max.	<5 W
Cooling Capacity	6 W (@4.2 K)
Rated Power	40 kW
<b>RF System</b>	
Frequency	72.8 MHz
RF Power	110 kW
Dee Voltage	80-130 kV
<b>Proton Source</b>	
Internal Cold Cathode PIG Type	
<b>Beam Properties</b>	
Energy	250 MeV
Max. Extracted Current	800 nA
Extraction Efficiency	80%
Mode	cw
Emittance hor.	$\leq 3\pi$ mm mrad
Emittance vert.	$\leq 5\pi$ mm mrad
Momentum Spread $\Delta p/p$	$\pm 0.2\%$
Number of Turns	650

## RF SYSTEM

### Overview

The cyclotron RF system consists of three major parts, the cyclotron resonator, the high power amplifier, and the low level RF (LLRF) system as shown in Fig. 1.

The cyclotron resonator is composed of four single spiral shaped half wave cavities. Two opposed cavities are inductively coupled at their dee nose, the other two are capacitively coupled. Eight shorting plates define the current maxima. They can be moved in order to tune the

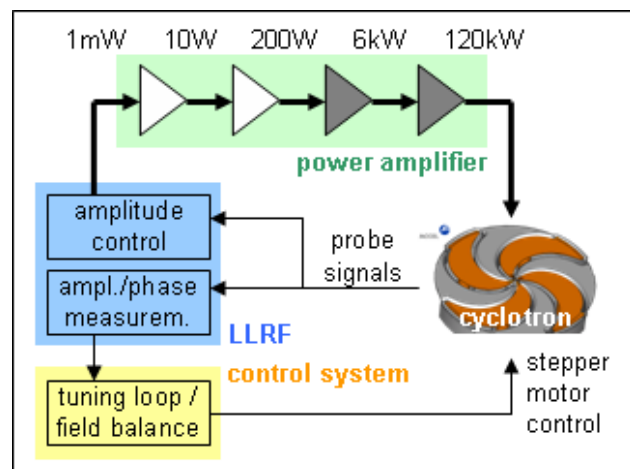

Figure 1: Main components overview of the RF system.

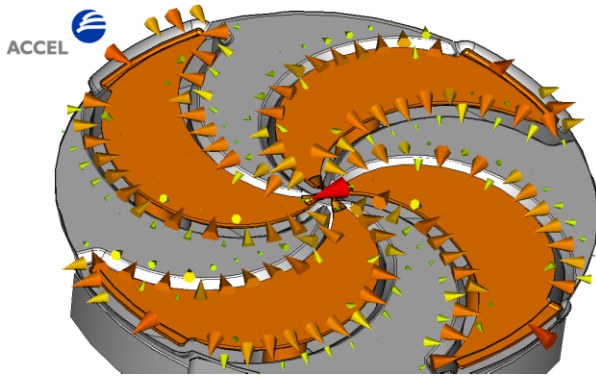

Figure 2: Push-Pull mode calculated with the CST Microwave Studio code; arrows indicate the electric field direction.

resonator.

The LLRF contains a fast feedback system for the stabilization of the amplitude of the gap voltages. It also provides the amplitude and the phase of probe signals to the control system. Based on these signals the resonator is tuned to resonance and to field balance by adapting the shorting plate positions. Field balance means that there is the same accelerating voltage amplitude applied to all four sectors.

The four-stage RF power amplifier delivers during normal operation about 110 kW to the cyclotron.

### Design

The resonator design was investigated in detail by ACCEL supported by the PSI [3] using appropriate models. The electrostatic design of the central region was refined using the TOSCA 3D code. The RF fields were calculated with the CST Microwave Studio code. Special care was attended to calculation of the mode separation. Fig. 2 shows the desired push-pull mode (1<sup>st</sup> mode) at 72.8MHz. In the 2<sup>nd</sup> mode the RF power oscillates between dee 1 and dee 3. In field balance this mode theoretically can not be excited because the coupling loop is located at dee 4, containing no field in the 2<sup>nd</sup> mode. The 3<sup>rd</sup> mode is called push-push mode. Here all four dees are oscillating in phase. The calculations showed that there is a sufficient distance between mode 1 and 3 to avoid accidental excitation of the 3<sup>rd</sup> mode.

Furthermore these calculations yielded appropriate

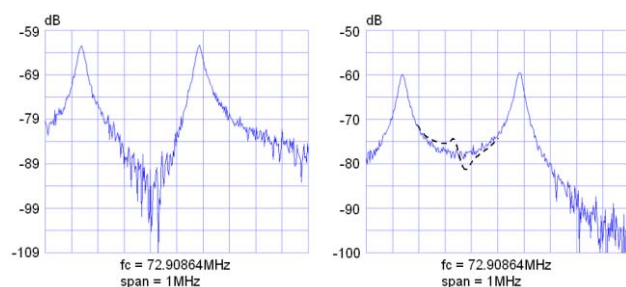

Figure 3: Pickup coupling measured with network analyzer at an inductively coupled dee (left) and at a capacitively coupled dee (right, dashed line showing qualitatively a curve for the 2<sup>nd</sup> mode).

shorting plate positions and allowed to evaluate the gap voltage distribution.

### Performance

Commissioning of the cyclotrons' RF systems started at the end of 2004 at PSI and in February 2005 at RPTC. As a starting point for tuning, the shorting plates of the resonators have been set to appropriate positions to meet the needed reference frequency and the field balance conditions. This was done by equalizing the coupling of the push-pull mode (1<sup>st</sup> mode) and the push-push mode (3<sup>rd</sup> mode) for each of the four resonators. As a consequence the 2<sup>nd</sup> mode at the capacitively coupled dees disappeared (see Fig. 3).

The RF systems were conditioned up to approximately 20 kW RF power within a few days. At approximately 10 kW the software controlled tuning loop that keeps the system in resonance and the field balance loop were put into operation without any problems.

When increasing the RF power to 60 kW problems were encountered at both machines with burned RF contact fingers at the backward rim of dee 3, the one that features the smallest gap to the midplane liner. This deficiency could be fixed by mounting of contact fingers that could withstand a higher current density and by directly measuring the dee voltage at high power levels via a self developed sophisticated X-ray detection and data fitting system (see section 'Diagnostics' below). The measurements showed that the voltage at dee 3 was about 20% higher than the mean value of all 4 dees. After a subsequent re-calibration of the field balance the nominal operation power of 120 kW and more could easily be reached. At subsequent inspections over the last two years all contact fingers have been in excellent shape.

In parallel the cause of the burned RF contact fingers was identified with the help of a detailed full size Microwave Studio model. It showed that the higher capacitance at dee 3, caused by the smaller gap to the liner, leads to a higher local current density (see Fig. 4) also at balanced fields. With the help of the model it was possible to specify the requirements for the RF contact fingers and the field balance more accurately.

The frequency distance between push-pull mode and push-push mode was determined to be 460 kHz

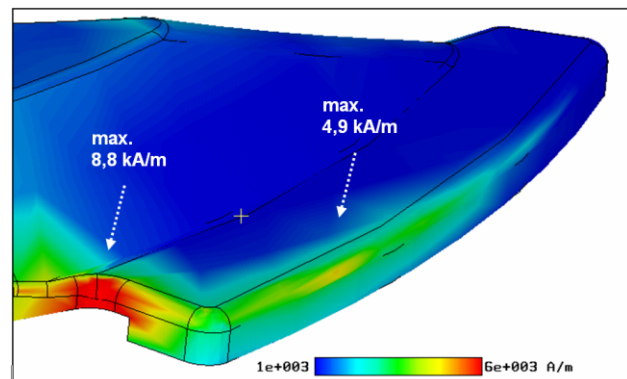

Figure 4: High current density at the backward rim of dee 3 calculated with CST Microwave Studio.

(simulation: 520 kHz). This is more than 20 times the bandwidth of the resonator structure and therefore sufficient for avoiding unwanted excitation of the push-push mode.

The RF systems of both cyclotrons are routinely operating with very high reliability. During normal operation the reflected power amounts only about -30 dB. After overnight shutdown it is possible to immediately switch on RF power. Furthermore, after closing the opened cyclotron only 1 hour is needed for pumping before the RF can be switched on again.

## CRYOGENIC SYSTEM

### Design

Industrial products must fulfill special requirements with respect to cost, reliability and maintainability, which is especially true for applications in a medical environment. These constraints are most apparently reflected in the design of the cryosystem where a closed-cycle zero boil-off LHe system using standard commercially available cryocoolers is applied for bath cooling the superconducting main coil. An important design goal was the reduction of the heat load to the coldmass using superinsulation and an actively cooled radiation shield. This shield encloses the complete coil cryostat and operates at a temperature of 70 K. Reliability was achieved by applying a comfortable safety margin to the cryogenic capability as well as to the coil design. The heat balance for standard operation was conservatively calculated to be 2.9 W at 4.2 K.

### Performance

For beam tuning purposes a 'radial beam probe' made from tungsten can be moved inside the acceleration chamber to monitor beam currents (see section 'Diagnostics'). During such measurements neutrons are generated by the stopped protons especially at larger radii in the vicinity of the coil cryostat where the beam has

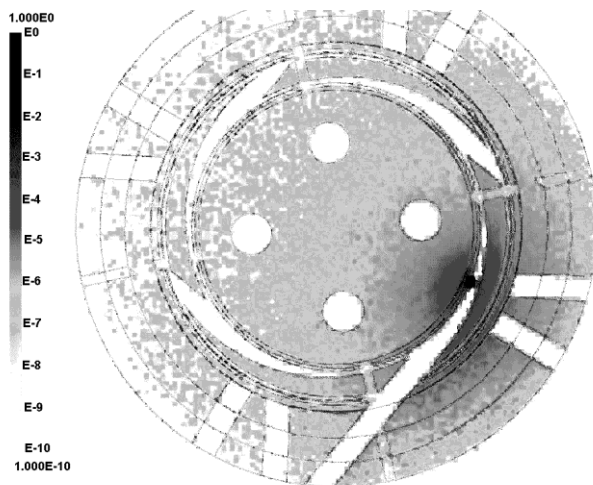

Figure 5: Power density of neutrons produced by a 250 MeV proton beam stopped inside the cyclotron; logarithmic gray scale ranges from  $10^{-10}$  to  $10^0$  W/cm<sup>3</sup>.

already gained its final energy. A sensitivity analysis showed that under extreme conditions neutrons add about 2.5 W to the heat load (see Fig. 5). As the four installed GM cryocoolers provide an internal refrigeration capacity of 6 W a safety margin is present even under non-standard operating conditions. Commissioning measurements showed that the real heat load of the cryostat is considerably lower, leaving a safety margin that easily allows switching off one of the four cryocoolers for maintenance purposes and providing an intrinsic redundancy. Moreover, the installed LHe supply cryostat allows at least 16 hours of cryogenic operation without any cryocoolers.

## SC MAGNET SYSTEM

### Design

While the current leads are made from a high-Tc superconductor the main coil wire consists of conventional low-Tc monolithic wire-in-channel material with an approximate Cu:sc ratio of 10:1. The current can be ramped with a maximum rate of 20 A/min as the power supply is capable to deliver 60 V.

The iron yoke consists of a pill-box configuration with an outer diameter of 3.2 m. Both the lower and the upper pole cap can be lifted quickly by means of a motorized jacking system, allowing fast and easy access to the inner cyclotron parts. This very compact design features a weight of only 90 tons as compared to >200 tons for an equivalent normal conducting machine.

### Performance

The magnet system was extensively tested and it was not possible to induce a quench during the factory tests without using the built-in quench heaters. At 160 A operating current and an equivalent of  $10^6$  ampere-turns it excites an induction of 2.4 T in the cyclotron center increasing to a mean value of  $\sim 3$  T at the beam extraction radius. The power consumption of the cryocoolers including the radiation shield coolers is only 40 kW whereas a comparable normal conducting coil needs a power supply of more than 200 kW and further provisions for cooling away ohmic losses. The superconducting coil can remain powered overnight at low cost, enabling faster start-up in the morning (10 min to first beam specified).

An iterative process of magnetic field measurements and shimming of iron plates on top of the magnet hills was used to isochronize the cyclotrons [2]. The success of this sophisticated process could be verified by modified Smith-Garren (beam phase) measurements [4].

## ION SOURCE

The internal, cold cathode ion source is similar to the source developed for the Harper Medical Cyclotron [5]. It consists of two halves featuring anode/cathode pairs whose arcs are used to ionize the supplied hydrogen gas. Both halves are connected via a 'chimney' in the cyclotron center where the protons are extracted from the plasma by the puller dee voltage. This source was

extensively tested at NSCL in a test facility with a DC acceleration electrode and subsequently integrated in the cyclotron. Predicting the output of the source in the RF cyclotron environment based on DC tests is not trivial but the initial configuration of the source came surprisingly close to the specified current. Only small changes to the slit size in the chimney were made to reach 800 nA of extracted current. After determining optimum operating parameters the short term stability of the source reached the specification necessary for the ‘pencil beam’ scanning as applied in the Varian/ACCEL proton therapy system. The more stringent requirements for the advanced scanning method of the PSI PROSCAN project needed additional optimization. This work, in which PSI played an instrumental role, is further described elsewhere in these proceedings [6].

Maintenance of the source is a straightforward procedure as the two halves of the source can be dismantled from the cyclotron without breaking the main vacuum. The time needed to exchange the source is 15 min and its maintenance interval is only once every 1 - 2 weeks.

Operational experience is very positive, after a short period of conditioning during the morning start-up procedure the source requires no additional attention.

## DIAGNOSTICS

The compact cyclotron design posed a challenge for the development of the beam diagnostics. As all four magnet valleys of the machine are occupied with dees the space available for diagnostics is very limited. Even the hill areas were hard to fully utilize as extraction elements partly block possible radial entry points and the strong spiral shape of the hills prohibit linear probes to reach the center of the machine. Furthermore, the RF field of the dees penetrates virtually every part of the acceleration chamber making appropriate RF shields and filters a necessity for every electrical measurement. The requirement of having a comprehensive set of beam diagnostics in combination with limited available space led to the development of several new diagnostic devices based on proven concepts.

The cyclotrons are equipped with one radial beam probe for which two measurement heads are available: one ‘integral current head’ for beam centering and extraction current measurements and one ‘viewer head’ containing a CCD camera and a scintillating screen to monitor axial beam motion. The performance of the viewer head was excellent from the start of commissioning and the high sensitivity of the scintillating screen made measurements with very low currents - letting hydrogen gas flow without even igniting the source was sometimes enough - and low activation possible. The use of low currents also increased the lifetime of the scintillating screen and CCD camera considerably.

The measurements with the integral head had a difficult start. The stray fields of the RF system allowed measurements only in specific ranges of the probe track,

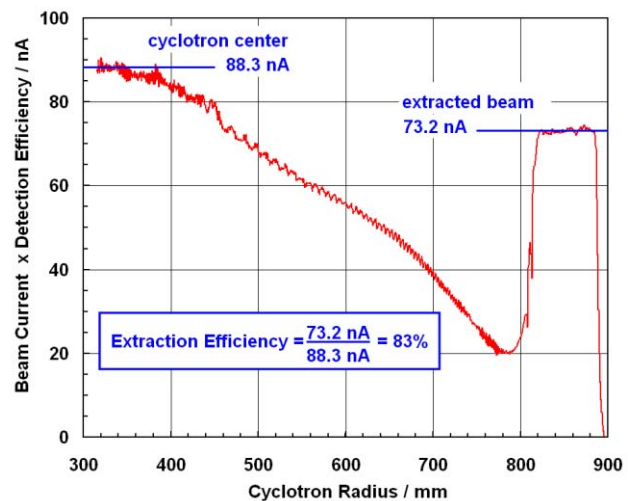

Figure 6: Beam extraction efficiency measurement.

at those places furthest removed from the RF cavities. Even at these positions the current readings were still unreliable and exhibited time-dependent noise signals. After exchanging already sophisticated electrical filters the performance was hardly improved. Only the installation of additional RF shields brought relief and subsequently detailed measurements could be performed. As seen in Fig 6 efficiency of the probe is reduced at intermediate energies due to a changing angle of incidence with radius, which was also confirmed by a theoretical model developed at the PSI [7]. The integral head proved to be a very useful tool for machine setup and measurements of extraction efficiency. The accuracy of the integral head measurements was confirmed with independent diagnostic tools.

At 215 mm radius from the cyclotron center two movable phase slits are installed in adjacent hills to cut part of the beam at low energy. Axial penetrations through the iron and the use of longer shafts allow the drive mechanisms of the slits to be mounted on the pole cap for easier maintenance. The slits are water-cooled and electrically isolated from the cooling circuit and the iron with a ceramic to enable a precise current measurement. As both the radial position of the slits and the widths can be changed, a variety of measurements can be done ranging from determination of radial beam distributions to transmission and extraction efficiency measurements. As the current measurements are available online the operator can in particular observe the ion source performance during operation. The combined transmission and extraction efficiency as measured with the slits consistently is a couple of percent higher than as measured with the radial beam probe.

Old-fashioned foil burns were used at extraction radius during commissioning to precisely position the extraction elements. The drawback of this technique is that the machine must be opened after each ‘burn’. In practice this was hardly a disadvantage as the time to vent, open, (dis)mount foils, close, pump, RF reconditioning, ion source switch-on and beam extraction was in the order of

2 - 3 hours. Several foil burns could be made per working shift and due to the reproducible behavior of the superconducting cyclotrons the results proved to be reliable and lasting.

Another technique used exclusively during commissioning was the measurement of bremsstrahlung spectra of stray electrons accelerated by the four RF cavities to calibrate and balance dee voltages. To determine the peak voltage a regression analysis of the spectrum - measured with a low cost X-ray detector - has been carried out using a non-linear multiple convolution model taking into account the energy gain of the stray electrons between the liner and the dee, the bremsstrahlung spectrum integrated over angle, the attenuation effects caused by liner and vacuum flange as well as the limited detector resolution [8]. After the dee balancing procedure the beam could be centered with a lower first harmonic 'centering bump'.

Several diagnostic elements such as profile and current monitors are mounted permanently in the beamline to measure beam properties after extraction. A non-destructive beam phase detector is mounted as first beam line element to measure and quantify the effect of phase shifts due to magnetic field drifts. This capacitive phase probe was specially designed to cover the intensity range from 800 nA down to a few nanoamperes of beam current [9]. The phase between beam and RF pickups is continuously measured and used as an input for a feedback loop controlling the coil current. The magnetic field of the cyclotron is tuned automatically and online to maintain a fixed pre-set phase value. The feedback loop optimizes the extraction efficiency continuously and thereby minimizes activation of the cyclotron. It also actively stabilizes the energy and the position stability of the extracted beam.

## AUTOMATION

In 2006 further refinements of the control system have been implemented. Several system status levels were defined and automatic transition routines have been introduced to guarantee reproducible system settings and a fast start-up after overnight shutdown. The time flow diagram in Fig. 7 illustrates this start-up procedure for the most important subsystems. Within the procedure the set

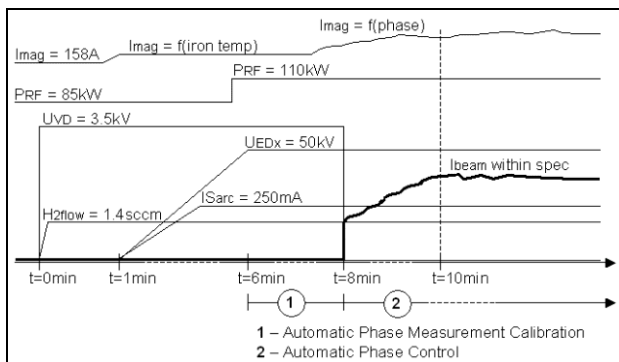

Figure 7: Time flow diagram showing relevant signals recorded during automatic transition from overnight shutdown to beam-on state.

value of the magnet current is calculated as function of the iron temperature. After setting the voltage of the vertical deflector – a pair of electrostatic deflector plates in the cyclotron center that can be utilized for fast intensity control at low beam energies – to  $U_{VD} = 0$  V (Fig. 7 at 8 min) external beam is directly available. Then the phase feedback loop (see section 'Diagnostics') tunes the magnet current to its optimal value to ensure reliable and stable beam operation. In total the cyclotron gets back to normal beam operation in the morning within 10 min by pressing only two knobs on the control system with a potential to reduce this time further down to approximately 5 min.

Furthermore, a comfortable beam current setting procedure was implemented. Based on an automatically generated look-up table slit widths are set to defined start values at the beginning of the current setting procedure. By controlled opening of these slits it is possible to set any current for the beam extracted from the cyclotron in the range of 1 nA to 800 nA as maximum current per treatment. Fast intensity modulation is subsequently performed with the vertical deflector.

Additionally service routines have been implemented in the control system that, e.g., optimize the phase slit positions. Several quality check procedures for analysis of the cyclotron performance are running automatically. An automatic routine for beam centering and settings of the extraction elements is currently under test.

## SYSTEM PERFORMANCE

### *Advantages of Using a Superconducting Coil*

The superconducting coil adds a significant portion to the total magnetic field. In particular at large radii the increase of the field needed to keep it isochronous is produced more or less by the coil on its own. Thus the magnetic gap can be kept constant reducing non-linear terms in the field. This reduces non-linearities in beam dynamics and therefore enables the optimization of beam extraction efficiency to more than 80%. The high extraction efficiency dramatically reduces activation of cyclotron internal parts.

### *Beam Properties*

Due to a performance better than expected the maximum intensity of extracted beam could be increased from the design value of 500 nA to 800 nA without noteworthy problems. The beam emittance was determined to meet the specifications of  $3\pi$  mm mrad horizontally and  $5\pi$  mm mrad vertically. Also the measured beam energies of 249.6 MeV at the PSI and 250.2 MeV at the RPTC together with a momentum spread of  $\Delta p/p = \pm 0.2\%$  are very well within specifications.

### *Standard Operation*

There are no planned interventions during daily standard operation of the cyclotrons and therefore nearly no operators are routinely required. Automation

procedures enable a comfortable operation, optimizing of machine parameters does not require special expertise. Advanced machine protection algorithms are implemented and with the aid of automation procedures operators have the ability to easily tune the system to the required performance. After a short start-up procedure in the morning the beam is available with reproducible constant properties.

### *Operation as Medical Cyclotron*

After system validation the PSI successfully started treatment of patients at the beginning of this year [10]. Within three months the system consisting of the ACCEL cyclotron and the PSI beamline reached an availability of >95% (according to PSI definition  $1 - DT/UT$ , where DT and UT denote the downtime and uptime, respectively).

### **MAINTENANCE**

Since 2005 the PSI cyclotron has delivered a total current integral of 72  $\mu\text{Ah}$ . Maintenance intervals for standard components as specified in the manual are still subject to change according to ongoing experience. The component that undergoes most frequently a maintenance service is the ion source. A simple cleaning process is conducted every two weeks, parts like chimney, cathodes or insulators are exchanged even less often. It is worth noting here that this work can be done without breaking the cyclotron main vacuum so that beam operation can normally be continued after approximately 1 hour.

Besides the ion source only a few components of both cyclotrons have undergone a single maintenance service so far. The RF windows and inner conductor cooling tubes of the couplers have been cleaned, the motorized pole cap jacking systems have been greased and - only at the RPTC - plates of the vertical deflector have been exchanged. The regular maintenance procedures for the cold heads and shield coolers were carried out. The electrostatic extraction deflectors, being the most irradiated internal components, are now installed for more than one year with beam operation.

Very recently a major inspection of the PSI cyclotron was conducted during a routine shutdown following the patient treatment period. 24 hours after beam-off the measured effective dose rate at the opened cyclotron was only 250  $\mu\text{Sv/h}$  which is considered to be very low.

### **CONCLUSIONS**

ACCEL's compact superconducting 250 MeV proton cyclotron at PSI has been commissioned and is fully operational. The RPTC cyclotron meets all technical requirements. All components work without noteworthy problems or restrictions. Patient treatment has successfully begun at the PSI. The design concept proved to be efficient and the extensive physical calculations are verified by excellent performance. Achievement of design goals validated the applicability of the cyclotrons in a clinical environment. High availability as well as

reproducibility and stability of performance fulfill the demanding requirements for medical devices. Moreover, operation is facilitated by automatic start-up and tuning procedures that strongly reduce the need for supervision by operators. The high extraction efficiency of about 80% minimizes activation of internal parts and hence supports a fast and easy maintenance.

### **REFERENCES**

- [1] H. Blosser et al., "Proposal for a Manufacturing Prototype Superconducting Cyclotron for Advanced Cancer Therapy", MSUCL-874, East Lansing, MI USA (1993).
- [2] A. Geisler et al., "Status Report of the ACCEL 250 MeV Medical Cyclotron", Proc. of 17<sup>th</sup> Int. Conf. on Cycl. and their Appl., Tokyo, Japan; 18 - 22 Oct. 2004, ed. A. Goto (2005) 178 - 182.
- [3] L. Stingelin, "Beam-Cavity Interactions in High Power Cyclotrons", Thesis no 3169, EPFL Lausanne (2005).
- [4] C. Baumgarten et al., "Isochronism of the ACCEL 250 MeV medical proton cyclotron", Nucl. Instr. and Meth. A **570** (2007) 10 - 14.
- [5] H.G. Blosser, "Superconducting Cyclotron Facility for Neutron Therapy", 10<sup>th</sup> Int. Conf. on Cycl. and their Appl., 1984.
- [6] M. Schippers et al., "Beam intensity stability of a 250 MeV SC cyclotron equipped with an internal cold-cathode ion source", these proceedings.
- [7] J.M. Schippers, "The SC cyclotron and beam lines of PSI's new proton therapy facility", oral presentation, ECPM 2006, Nice, France.
- [8] J.H. Timmer et al., "DEE Voltage Calibration for the ACCEL Proton Therapy Cyclotron", Proc. of ICAP 06, Chamonix, France (2006) 102 - 105.
- [9] J.H. Timmer et al., "Automated cyclotron tuning using beam phase measurements", Nucl. Instr. and Meth. A **568** (2006) 532 - 536.
- [10] J.P. Duppich et al., "The First Year of Patient Treatment at PSI Using the New Superconducting Cyclotron COMET", these proceedings.