

RADIO FREQUENCY SYSTEM OF THE CYCLOTRON C400 FOR HADRON THERAPY

Y. Jongen, M. Abs, W. Beeckman, W. Kleeven, D. Vandeplassche, S. Zaremba,
IBA, Belgium,
A. Glazov, S. Gurskiy, G. Karamysheva, N. Morozov, JINR, Dubna, Russia

Abstract

A dedicated Carbon/Proton therapy superconducting C400 cyclotron has been designed at IBA (Belgium) in collaboration with the JINR (Dubna) [1]. The cyclotron will be able to deliver ion beams with a charge to mass ratio of 1/2.

It is planned to use two normal conducting RF cavities for ion beam acceleration. Magnetic field modeling and beam dynamics have determined the orbital frequency of the ions equal to 18.75 MHz. As RF cavities will be operated in the 4th harmonic mode, the resonance frequency must be 75 MHz.

RF CAVITY GEOMETRY

The geometrical model of the double-gap delta cavity housed inside the valley of the magnetic system of the C400 cyclotron was developed in the Microwave Studio. A view of the model is presented in Fig. 1, Fig. 2. The depth of the valley permits accommodation of the cavity with the total height 116 cm. The vertical dee aperture was equal 2 cm. The accelerating gap was 6mm at the center and 40 mm in the extraction region. The distance between the dee and the back side of the cavity was 45 mm. The azimuth extension of the cavity (between the middles of the accelerating gaps) was 45 deg to the radius 100 cm (see Fig. 3). The cavities have a spiral shape similar to the shape of the sectors. We inserted four stems with different transversal dimensions in the model. We investigated positions of the stems to insure increasing voltage along radius. As a result, the stems were centered at the radii 38, 88, 150 and 175.5 cm. The thickness of the dee was 20 mm. The edges of the dees are 10 mm wide. From the 2D electric field simulations we chose optimal form of the dee edges. (see Fig. 4).

Each cavity will be excited with the RF Generator through a coupling loop (which should be rotated azimuthally within small limits. For precise cavity adjustment, a tuner (piston) will be provided at radii compatible with the holes in the yoke.

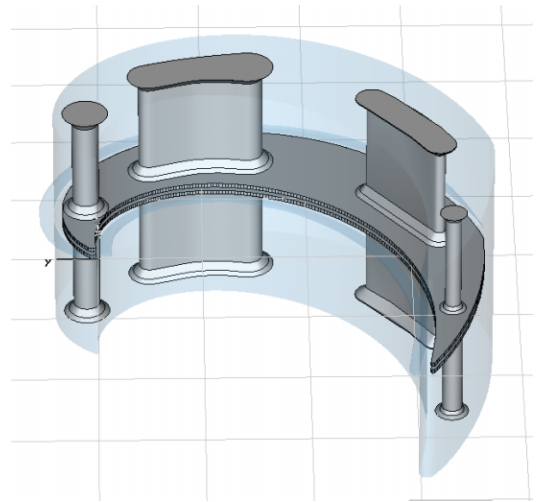

Figure 1: View of the cavity model.

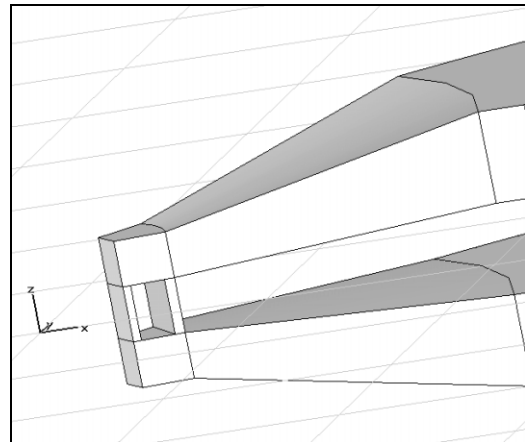

Figure 2: View of the dee tip.

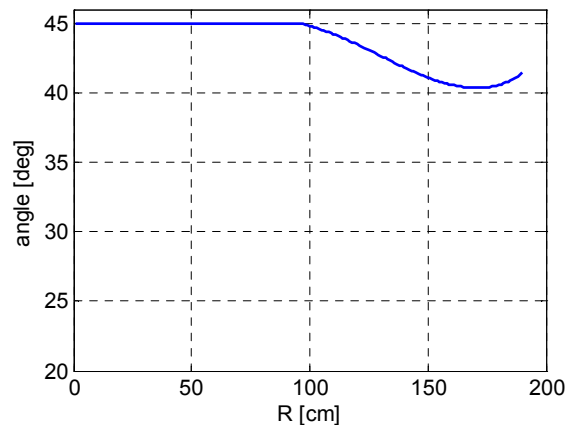

Figure 3: Azimuth extension of the cavity (between the middles of the accelerating gaps).

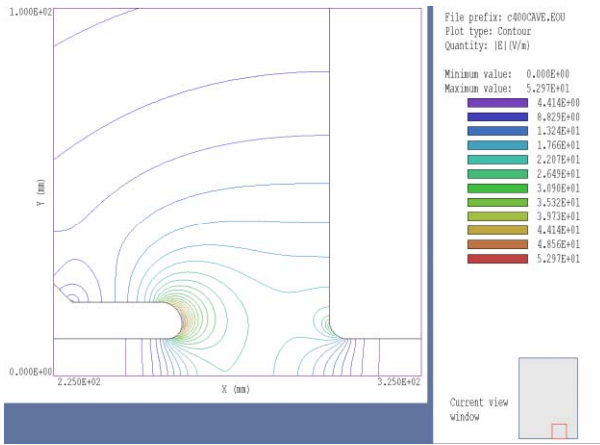

Figure 4: View of the edge of the dee.

SIMULATIONS IN CST MICROWAVE STUDIO

Calculations were performed by means of eigenmode JD lossfree solver for the number of meshcells up to 3000000.

In order to shape the radial voltage distribution, we moved stems and investigated voltage value against radius.

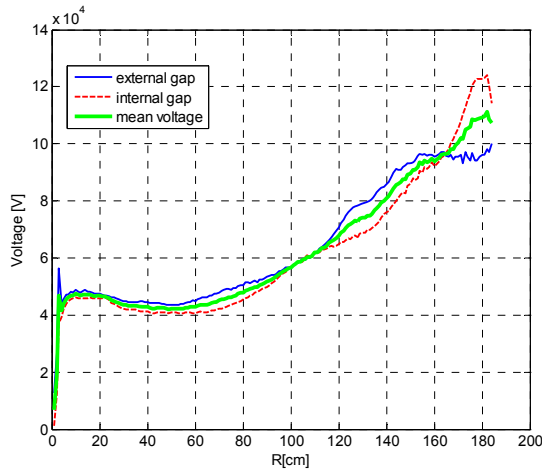

Figure 5: Voltage distribution along the gap: the internal gap-red line, the external gap-blue line, average voltage-green line.

As a result, the voltage distribution satisfying our demand (Fig. 5) was obtained. Voltage value was obtained by integrating the electric field in the median plane of the resonant cavity.

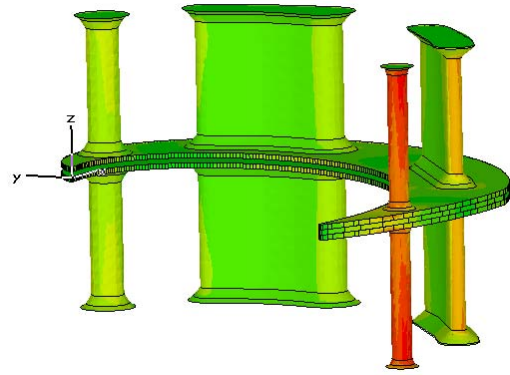

Figure 6: Surface current distribution on the dees and stems.

The surface current distribution on the dees and stems is presented in Fig. 6. The maximum current density is in the external gap and is equal to about 6500 A/m. The energy density in this region is about 24 J/m³.

To get the projected frequency after rearranging stems, we changed horizontal dimensions of all stems. It was necessary to change the horizontal dimensions of stems by percents to decrease the frequency by kHz's. The voltage along the radius did not change noticeably.

The quality factor of the model was 12500. Losses were 72000 losses /W_{peak} (for stored energy 1 Joule)

Each cavity will be powered by a 75 MHz, 100 kW tetrode-based amplifier (as used in the current C235)

We performed calculations of the model for different number of meshcells. Fig. 7 shows dependence of the frequency on the number of meshcells.

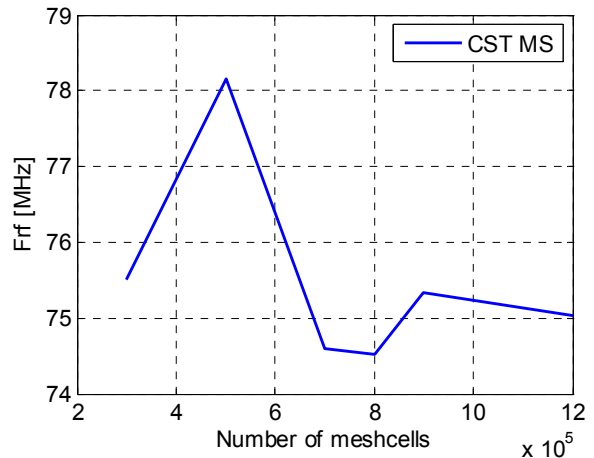

Figure 7: Resonance frequency against number of meshcells.

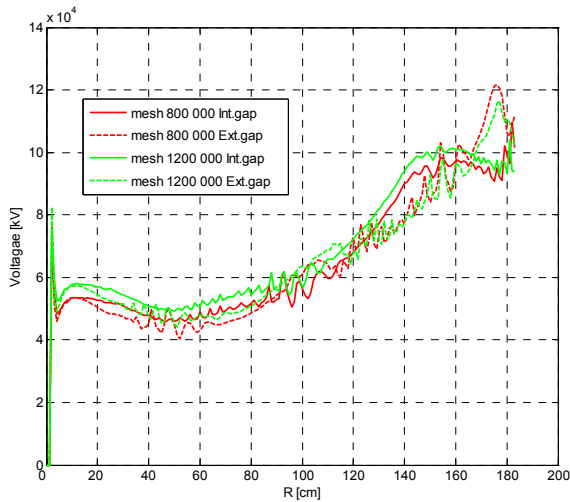

Figure 8: Voltage distribution along the gap of the model for different numbers of meshcells.

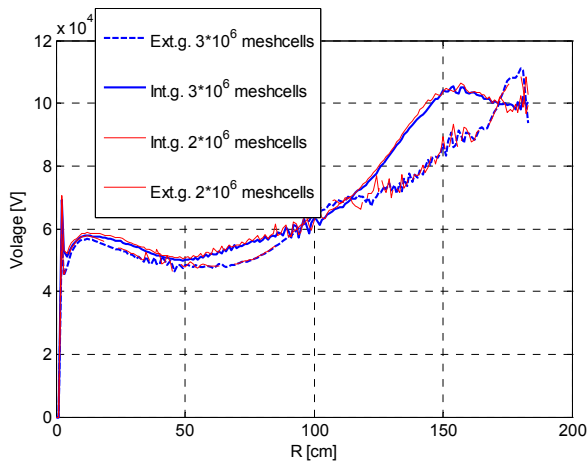

Figure 9: Voltage distribution along the gap of the model for different numbers of meshcells.

From Fig. 8 we see that the difference in voltage obtained from the simulations with 800000 and 1200000 meshcells is about 5 kV. It is clear that the number of meshcells for the current model is not enough. Fig. 9 presents the result of simulation for 2 million and 3 million meshcells. The difference between the voltage values is negligible but beating of voltage along radius noticeable, for example, in radii 150 is smaller for a larger number of meshcells. It is necessary to work with at least 2 million meshcells.

For the beam dynamics simulation, the radial and azimuth electric field components (Fig. 10) and the magnetic field (Fig. 11) maps were created.

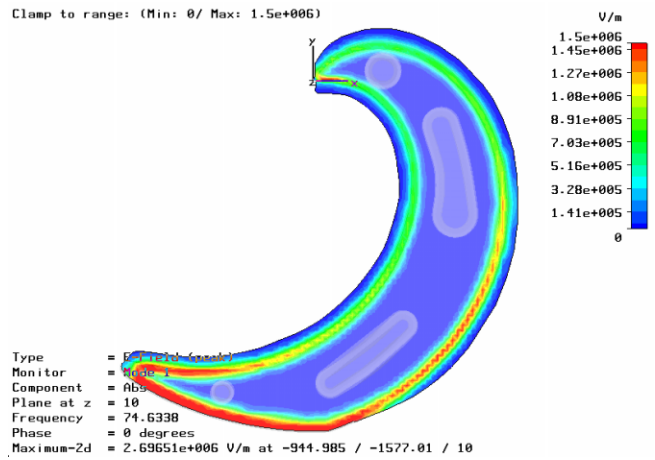

Figure 10: Electric field distribution.

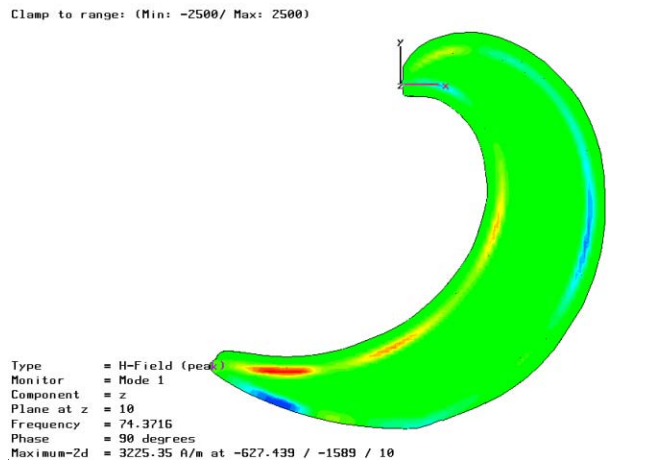

Figure 11: Magnetic field in the median plane.

CONCLUSION

A computer model of the double-gap delta RF cavity with 4 stems was developed in the Microwave Studio. The resonant frequency of different versions of the model was in the range 74.2-77 MHz. A necessary increase in the voltage along the gaps was attained. The voltage behavior along the radius depends substantially on the position of the stems. It was demonstrated that the frequency value can be changed by scaling transversal dimensions of all stems without essential modification of the voltage dependence on the radius.

REFERENCES

- [1] G.Karamysheva et al., "IBA C400 Cyclotron Project for Hadron Therapy", this conference.