

TEST BEAM LINE FOR PULSED BEAM GENERATION AT CIAE'S CRM CYCLOTRON

SZ.An*, LC.Wu, Tianjue Zhang, GF.Song, YL.Lu, XL.Jia, FP.Guan, YJ.Bi, B.Ji, JJ.Yang, SM.Weil, CJ.Chu, JS.Xing, ZG.Li, ZH.Zhou, GF.Pan, ZG.Yin, SG.Hou, T.Ge, LP.Weng, F.Yang
China Institute of Atomic Energy, Beijing, 102413, P.R. China

Abstract

A test beam line for pulsed beam generation for 10 MeV Central Region Model (CRM) compact cyclotron is being constructed at China Institute of Atomic Energy (CIAE). About 10 mA H- beam from a multicusp source is injected into the central region of CRM cyclotron. To provide the pulse beam from the CRM cyclotron, a new beam line with pulsed system for the injection is needed. A 70MHz buncher and a 2.2MHz chopper are designed for the beam pulsed system. A pulsed proton beam with 4.4MHz repetition rate and pulse length of less than 10ns is expected to be provided by CRM cyclotron. The energy spread produced by buncher and chopper are calculated and the emittance growth due to the chopper is considered.

INTRODUCTION

In order to study the critical technologies about the cyclotron with high beam intensity, A 10 MeV central region of model (CRM) compact cyclotron has constructed at China Institute of Atomic Energy (CIAE). Now the H- beam has been injected into the central region successfully. A test beam line for pulsed beam generation system for 10 MeV CRM compact cyclotron is being constructed at CIAE. A 70MHz continuous H-beam with the energy of several decades KeV or a hundred KeV will be pulsed to the pulse length of less than 10ns with the repetition rate of 1-8MHz. The first step is to get the pulsed H- beam in the injection line, then the pulsed beam will be injected into the CRM cyclotron.

The buncher and chopper systems will be the main parts in the beam pulsing system. In order to get good matching with the CRM cyclotron, the frequency of 70.487MHz used in the cyclotron will be adopted as the working frequency of buncher. The design of the chopper is the critical part in the pulsing system. The sine waveform with the frequency of 2.2MHz will be used as the working frequency of the chopper after many discussions and the chopped pulse length will be less than 8ns. Now, the design of injection line including the pulsing system has been finished.

THE DESIGN OF BUNCHER

The basic theory of the buncher

The buncher system is the one of the main parts in the pulsing beam generation system for CRM compact cyclotron and it will modulate the beam in the longitudinal direction. The beam with special phase width will be compressed into very short pulse in the time with buncher. With the modulation of a buncher, the charged particles in the continuous beam segments will come into being very short pulse after a long drift, and this pulse length should be less than the RF phase acceptance of the CRM cyclotron, that is, the pulsed beam can be captured by the RF system of the cyclotron completely. Because the velocities of the charged particles will be modulated with the buncher, an energy spread in the pulsed beam will be introduced. This energy spread affects not only the pulse length, but also the injection matching to the cyclotron. The drift in the buncher will affect the bunching voltage, which will decide the energy spread, and the space charge effects for different drifts will affect the bunching efficiency. So, for the design of buncher, the energy spread produced by buncher system and bunching efficiency affected by space charge effects will be studied in detail.

For the CRM cyclotron, the 70.487MHz RF phase acceptance is $\pm 30^\circ$ and the corresponding pulse length is 2.36ns. This pulse length will meet the requirement of pulsed system. The buncher will adopt the same frequency of 70.487MHz. The mesh structure with single drift and dual gaps will be used in the buncher, see Fig.1. The signs from RF amplifier will be added into inner meshes and outer meshes will be grounded. The silk in the mesh is made of gold-filled tungsten and the thickness of the silk is about $50\mu\text{m}\sim 100\mu\text{m}$. The distance between the mesh is 5mm, the distance between the silk is 3mm, and the length of middle electrode is 20mm($0.5\beta\lambda$, adjustable). The drift for the buncher is 1.4m in the pulsing beam line with the length of 2.362m in total. The bunching waveform is used sine form under non-relativity and the amplitude of the bunching voltage can be expressed ^[1]:

* szan@ciae.ac.cn

$$V_m (kV) = 35.4 \cdot \frac{1}{f (MHz) \cdot L(m)} \quad (1)$$

The amplitude of the bunching voltage is $V_m=0.363kV$. So $V_m<1.5kV$ is enough for the amplitude of the bunching voltage.

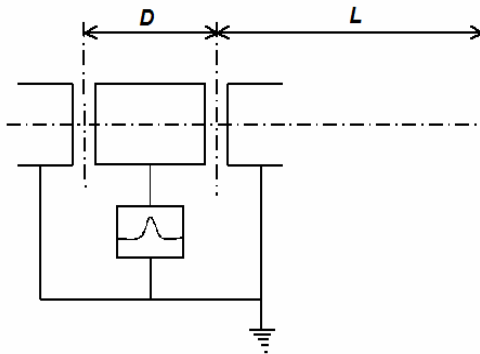

Fig.1: The structure of buncher

Simulation of the buncher

Figure 2 and Table 1 show the simulation results for the buncher with different beam current. From the results, the bunching efficiency η is about 63.5% and the produced energy spread is 1.5% for the zero beam current case. The bunching efficiency is reducing as the increasing beam current at the drift of 1.4m. It reduces to 52% under the 3.5mA beam current, and the energy spread is reduced to 1.1% at the same time. So, the acceptable beam current should be controlled under 3mA.

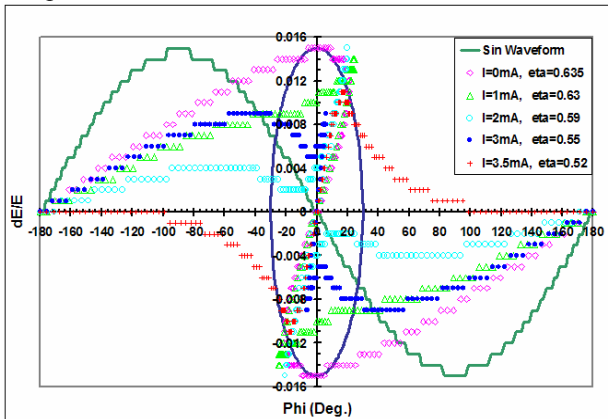

Figure 2: The simulation results with different beam current.

Table 1: The amplitude V_m , maximal energy spread $\Delta E/E$ and bunching efficiency η .

I (mA)	V_m (V)	η (%)	$\Delta E/E$ (%)
0	585	63.5	1.5
1	670	63	1.4
2	698	59	1.5
3	750	55	1.4
3.5	780	52	1.1

THE DESIGN OF CHOPPER

The parameters of chopper

For the buncher system with the sine waveform, the beam with phase width of 100° will be bunched in effect. So the pulse length got from beam chopper should be less than this phase width. In order to increase the effective beam current, the good bunching efficiency should be kept. The period for the buncher with frequency of 70.487MHz is 14.18ns and the pulse length should be less than 8ns after chopper.

In the beam pulsing system for the CRM cyclotron, the design of the chopper will be the key part due to the very short pulse length ($<10ns$), especially the choice of the chopping waveform. In order to get the pulsed beam with repetition of 1~8MHz and pulse length of 8ns, the sine waveform is used in the chopper. The frequency of the chopper is chosen 2.2MHz, which is the 32-divided RF frequency of the buncher. So we can get the pulsed beam with repetition of 4.405MHz after the chopper.

The structure of beam chopper is shown in Fig.3. The symbols in the figure: l- the length of the plate, g- the gap of the plates, S- the drift distance between the chopper and working slit, r- the radius of the slit.

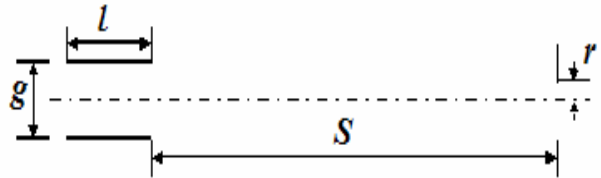

Fig.3: The structure of beam chopper

The waveform used in the chopper is sinusoidal and it will be excited symmetrically with the amplitude of $V_m/2$ on each plate in anti-phase:

$$V(t) = V_m / 2 \cdot \sin(\omega t + \varphi_0) \quad (2)$$

For the chopped pulse length of 7ns or ± 30 for 2.2MHz, the parameters of chopper is chosen: length of plate l is 100mm; the width of the plate is 50mm; the thickness of the plate is 5mm; the gap of g is 40mm, the amplitude of voltage $V_m=12kV$.

The simulation results for the chopper

The beam energy from ion source is 40KeV and the transfer time of the particles in the chopper for the length of plate l of 100mm is $t_c=36ns$ or $\varphi_c=28.6^\circ$. So the buncher center for the chopped pulse length of 7ns should be with the initial phase of $-\varphi_c/2=-14.3^\circ$. The edge of the particles in the pulse with length of 7ns should be with the initial phase of $-\varphi_c/2\pm 3^\circ$. After chopper, the obtained net kick for the bunch center is zero and the kick for the particles at the edge of pulse will be $\pm 19.5mrad$. Figure 4 shows the kick after chopper for the particles in the pulse with length of 7ns.

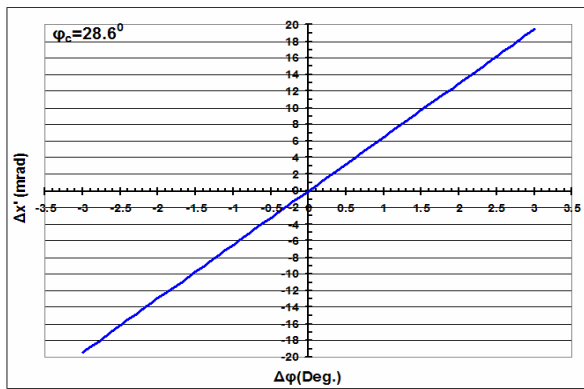

Figure 4 Obtained kick after chopper for the particles inside the pulse with $\Delta\phi = \pm 3^\circ$.

If the drift between chopper and slit is 50Cm, the single particles' movement for the bunch center and the edge particles in the pulse are shown in Fig.5. Here we just consider the paraxial transfer for the particles with the initial transverse coordinate of $x=x'=0$. All the particles in the pulse with length of 7ns have the negative displacements in the chopper. The size of working slit for the chopper should be the displacements of edge particles in the pulse at the position of slit. In order to get the short pulse length, the obtained kick after chopper for the edge particles in the pulse can ensure the displacements of the edge particles at the position of slit larger than the beam envelope by factor 2.

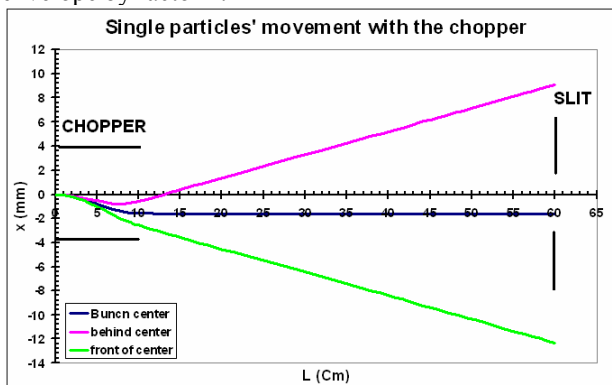

Fig.5 The single particles' movements with chopper.

THE DESIGN OF INJECTION LINE

Figure 6 shows the injection line, which is calculated by code TRACE-3D [2]. Considering the limits of the space, the buncher and chopper systems will be put together in the pulsing system. This choice will be compact and the beam line is not long. This design adopts ESQQ focusing structure. The continuous H- beam with the energy of 40KeV from the multi-cusp ion source is focused into two long waists by the Einzel lens at first and the beam chopper and buncher are put at this waists. The chopper is put behind the buncher and both of them will be put the same vacuum chamber. The beam after the buncher and chopper will be transported into the inflector of CRM cyclotron by the solenoid and quadrupoles. The phase advance from chopper to the working slit is 45° [3].

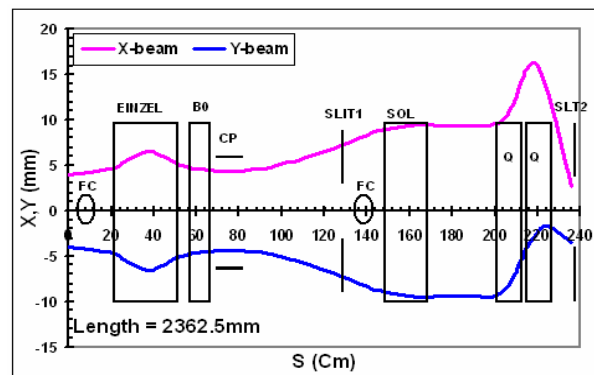

Figure 6 Layout of injection line and the beam envelope. (FC-Faraday cup, EINZEL-Three-aperture einzel lens, SOL-Solenoid, Q-Quadrupoles, STR-Steering magnets).

SUMMARY

A test beam line for pulsed beam generation based on the cyclotron is being constructed at CIAE. A 70MHz buncher and a 2.2MHz chopper are designed for the beam pulsed system. A pulsed proton beam with 4.4MHz repetition rate and pulse length of less than 10ns is expected to be provided by CRM cyclotron. The energy spread produced by buncher can be controlled less than 1.2%. Both the energy spread produced by the chopper [4] for the shorter pulse and the emittance growth after the chopper need the small emittance after ion source. So, the special emittance limiting devices is needed after ion source. The emittance after ion source can be controlled less than $50\text{-}\pi\text{-mm-mrad}$ under 3mA.

ACKNOWLEDGEMENTS

The authors would like to give the grateful acknowledge to Prof. Jingyu Tang from Institute of High Energy Physics, Prof. Jianqin Lu from Peking University, Dr. Klaus Bongardt from FZJ-Juelich, Dr. Calabretta from LNS of Italy about lots of discussions and useful suggestions from them and Prof. Tang give us the code to calculate the.

REFERENCES

- [1] Lu Jianqin, Quan Shengwen, Beam Pulsing System for the 4.5MV Electrostatic Accelerator at Peking University, Atomic Energy Science and Technology Vol.29, Mar. 1995.
- [2] K. R. Crandall and D. P. Rusthoi, TRACE 3-D Documentation, LA-UR-97-886, May 19
- [3] K.L.BROWN, Beam envelope matching for beam guidance systems, NIM 187 (1981) 51-65
- [4] J.Belmont, W.Joho, chopping and bunching on the TRIUMF 300 KeV Injection Line, TRI-DN-73-16, May 1973