

Large Momentum Acceptance Carbon Ion Gantry

Dr. Dejan Trbojevic
Brookhaven National Laboratory

The state of the art proton gantry at PSI

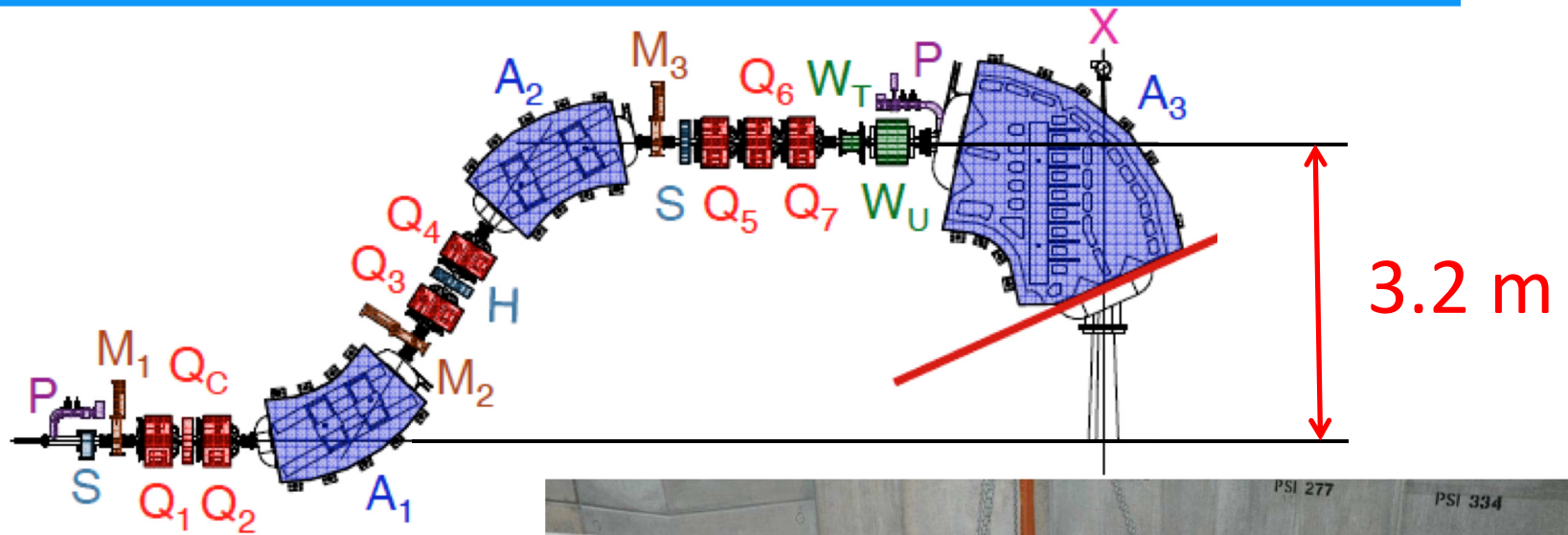

SAD – SOURCE-TO-AXIS-DISTANCE

Scanning system: applied for patent by BNL

The maximum dose to the patient surface relative to the dose in the SOBP increases as the effective source-to-axis distance (SAD) decreases. For a fixed, horizontal beam, large SAD's are easy to achieve; but not for gantry beam lines. A smaller gantry with a physical outer diameter of less than 2 meters may have important cost implications. Such a gantry would require magnetic optics to ensure that the effective source-to-axis distance is large enough to provide adequate skin sparing.

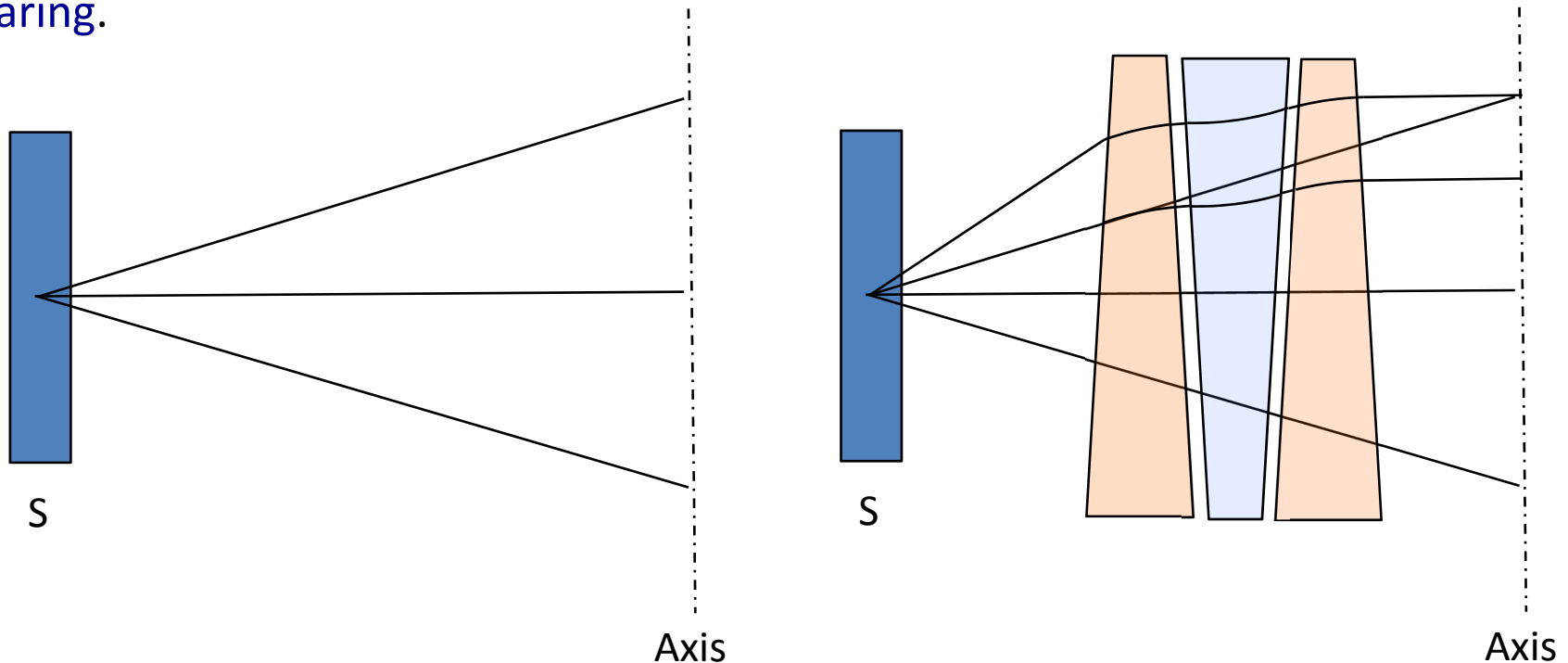

The state of the art proton gantry at PSI



Proton only gantry – warm small iron magnets

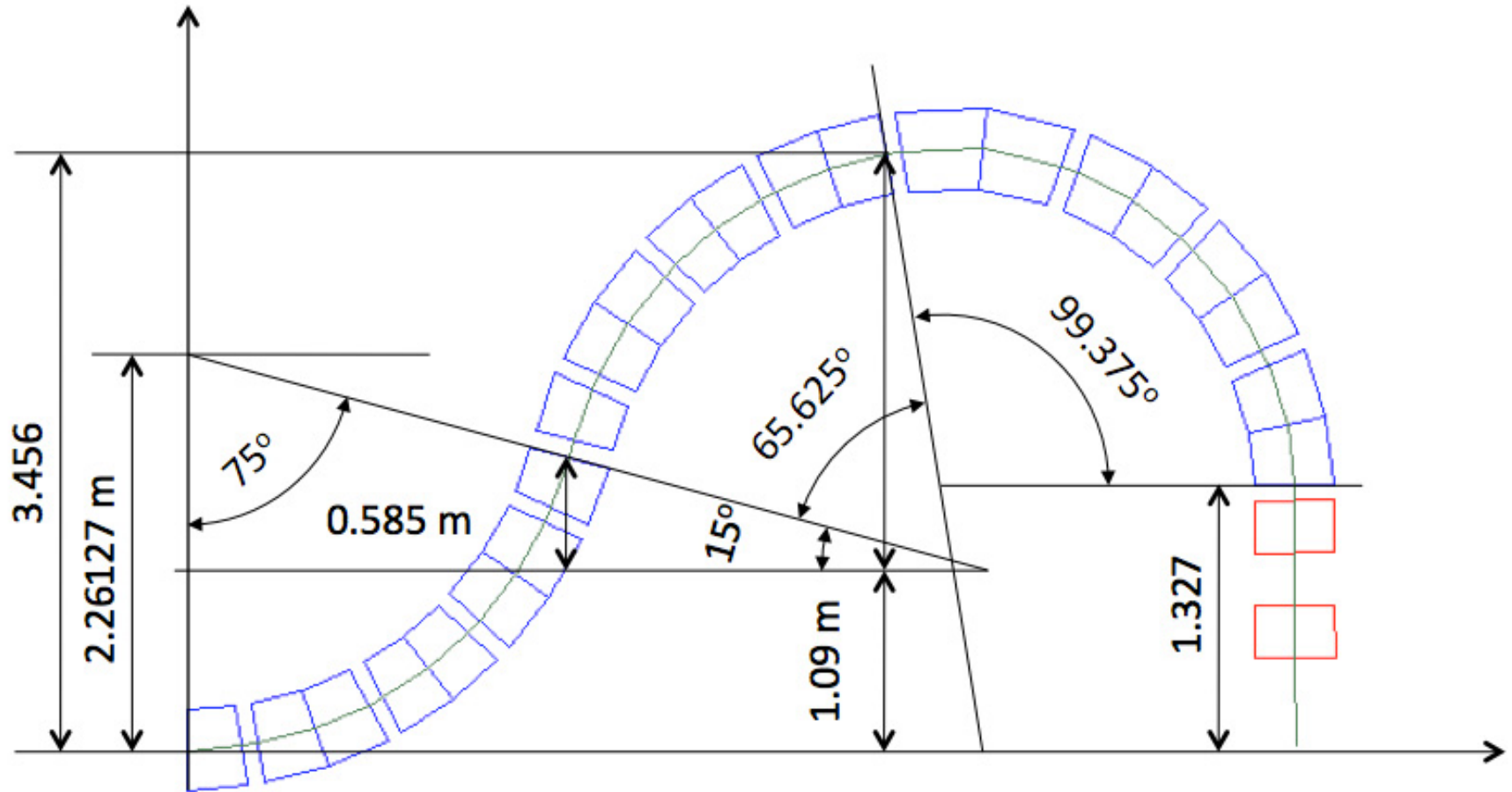

Scanning – proton isocentric gantry



±10 cm
Magnification 5X

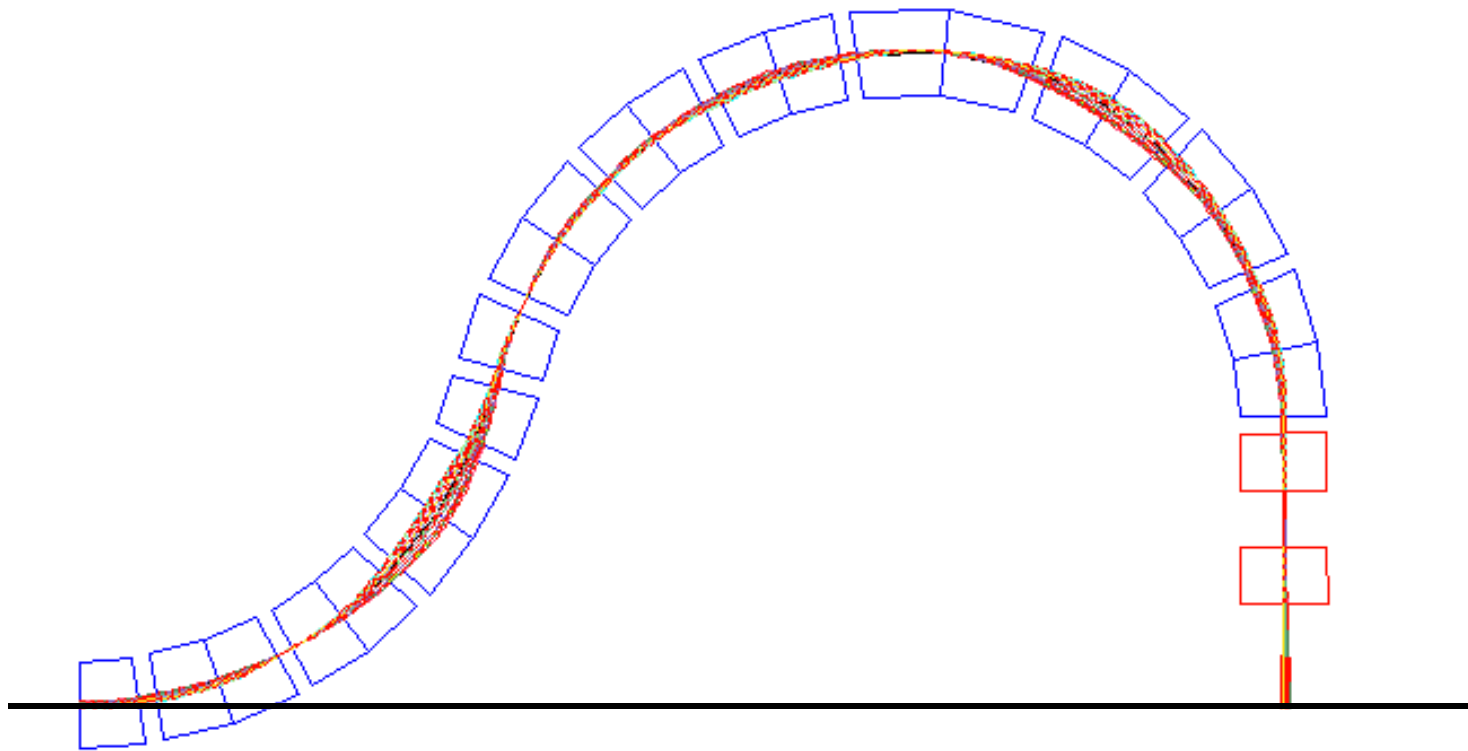

±10 cm
Magnification 5X

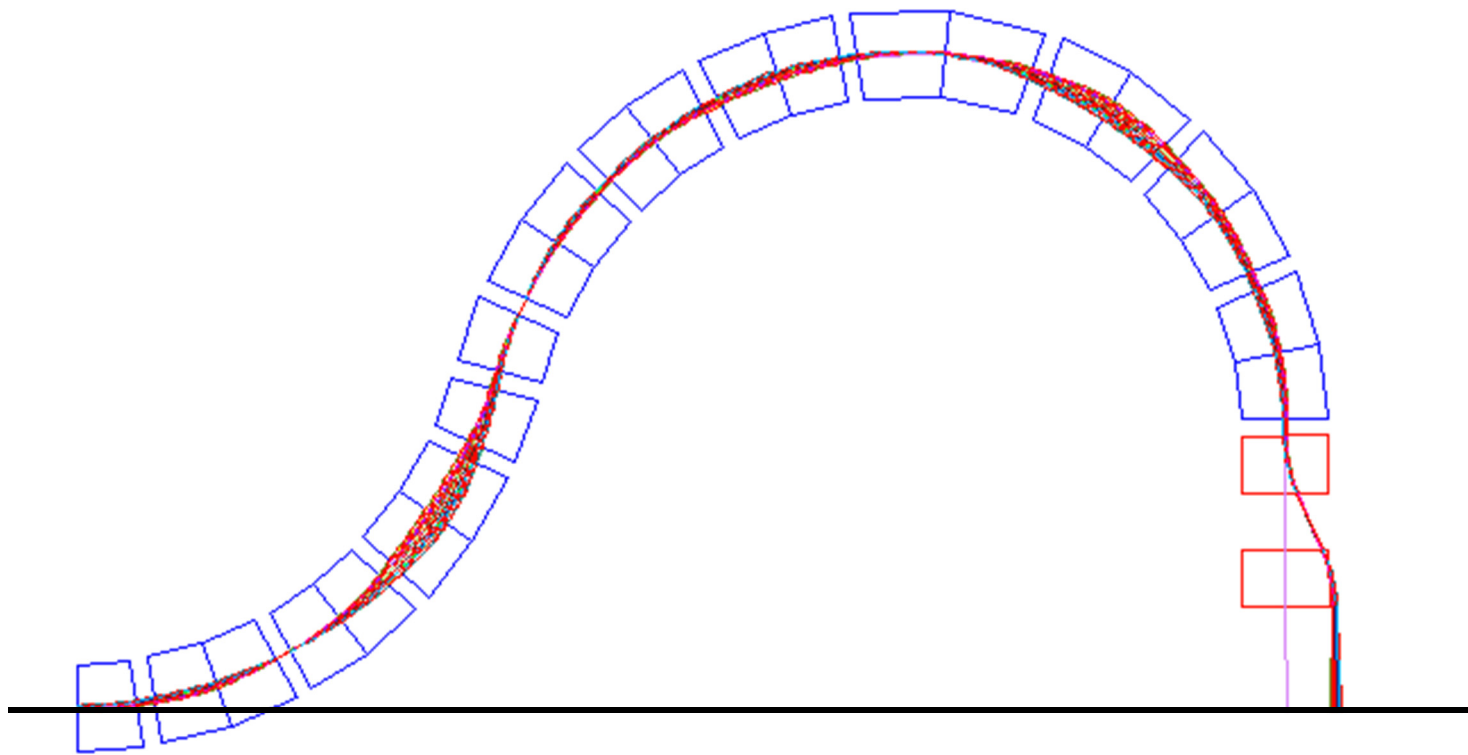

± 10 cm
Magnification 5X

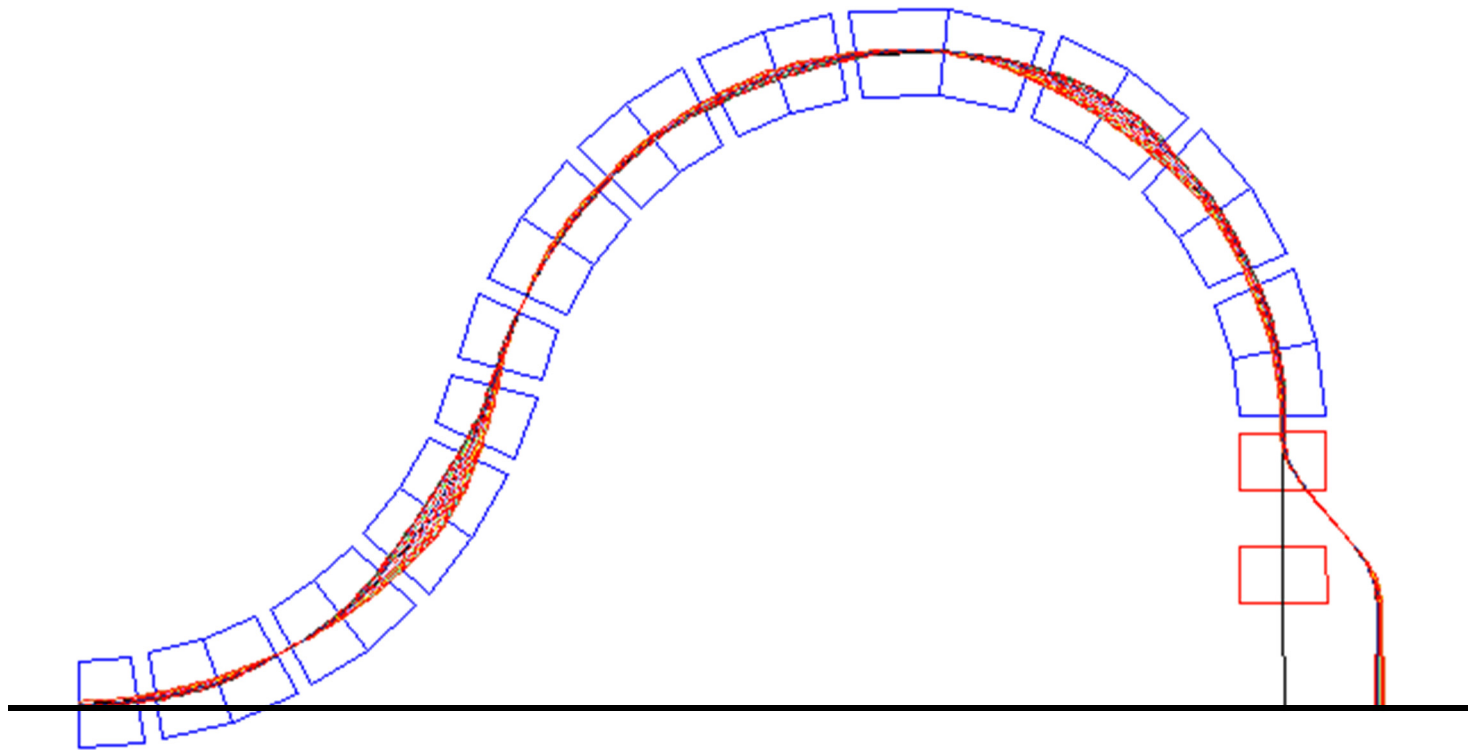

±10 cm

Magnification 5X

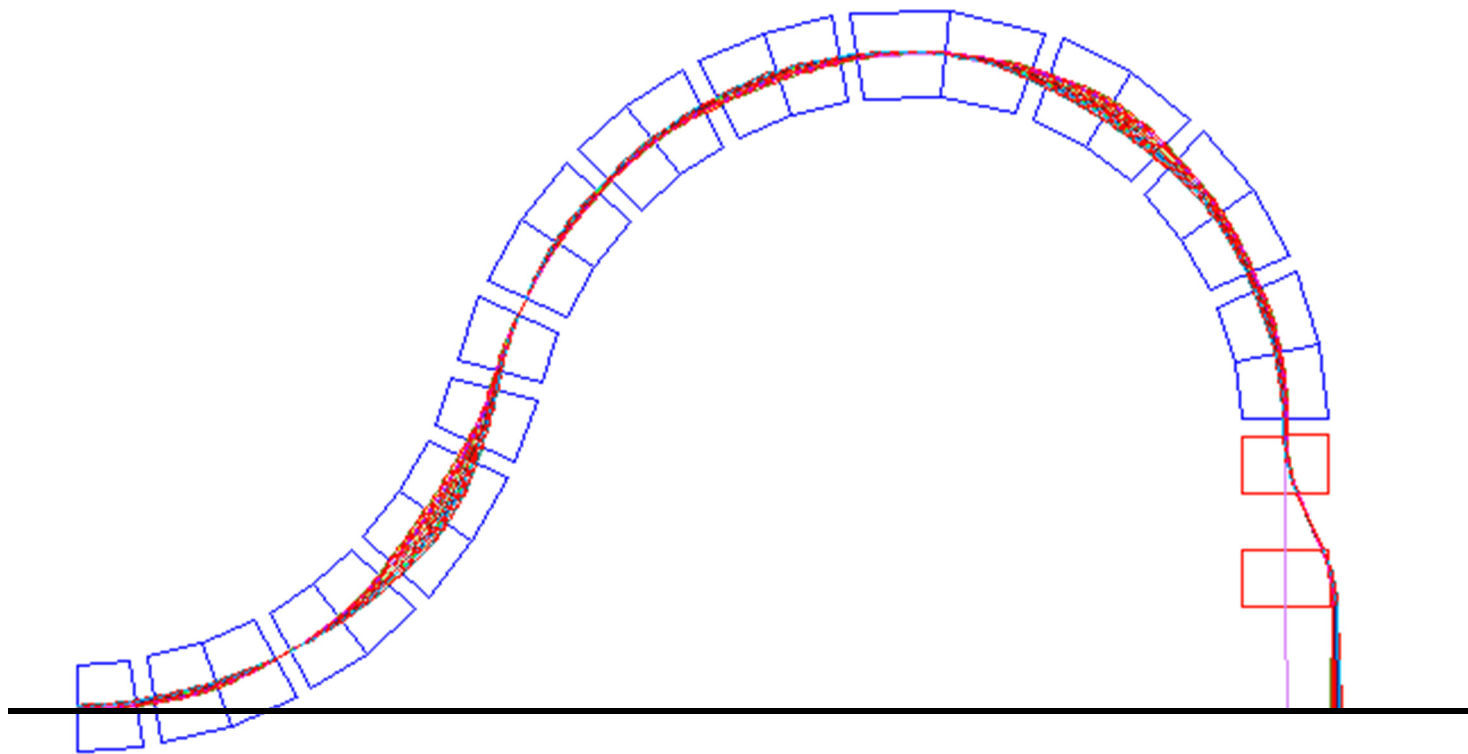

±10 cm

Magnification 5X

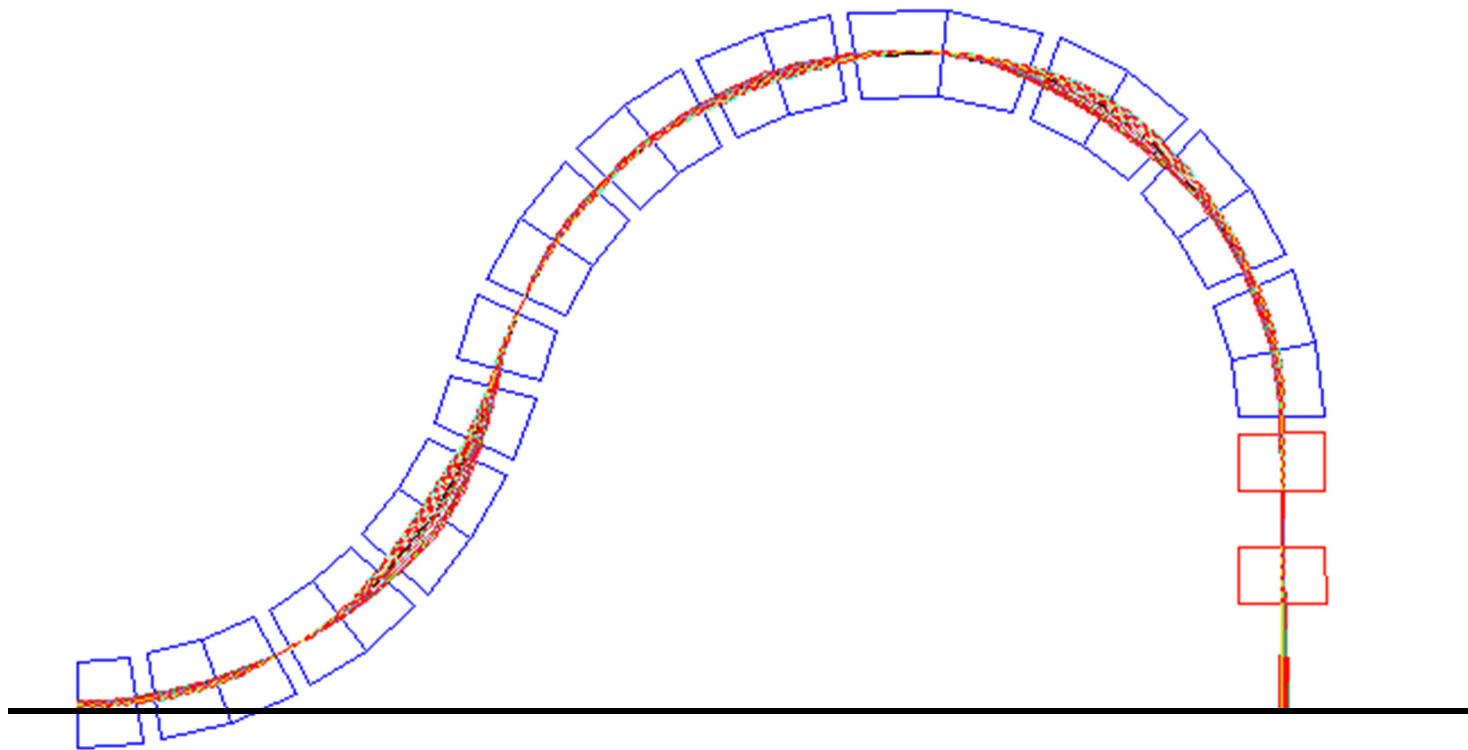

±10 cm
Magnification 5X

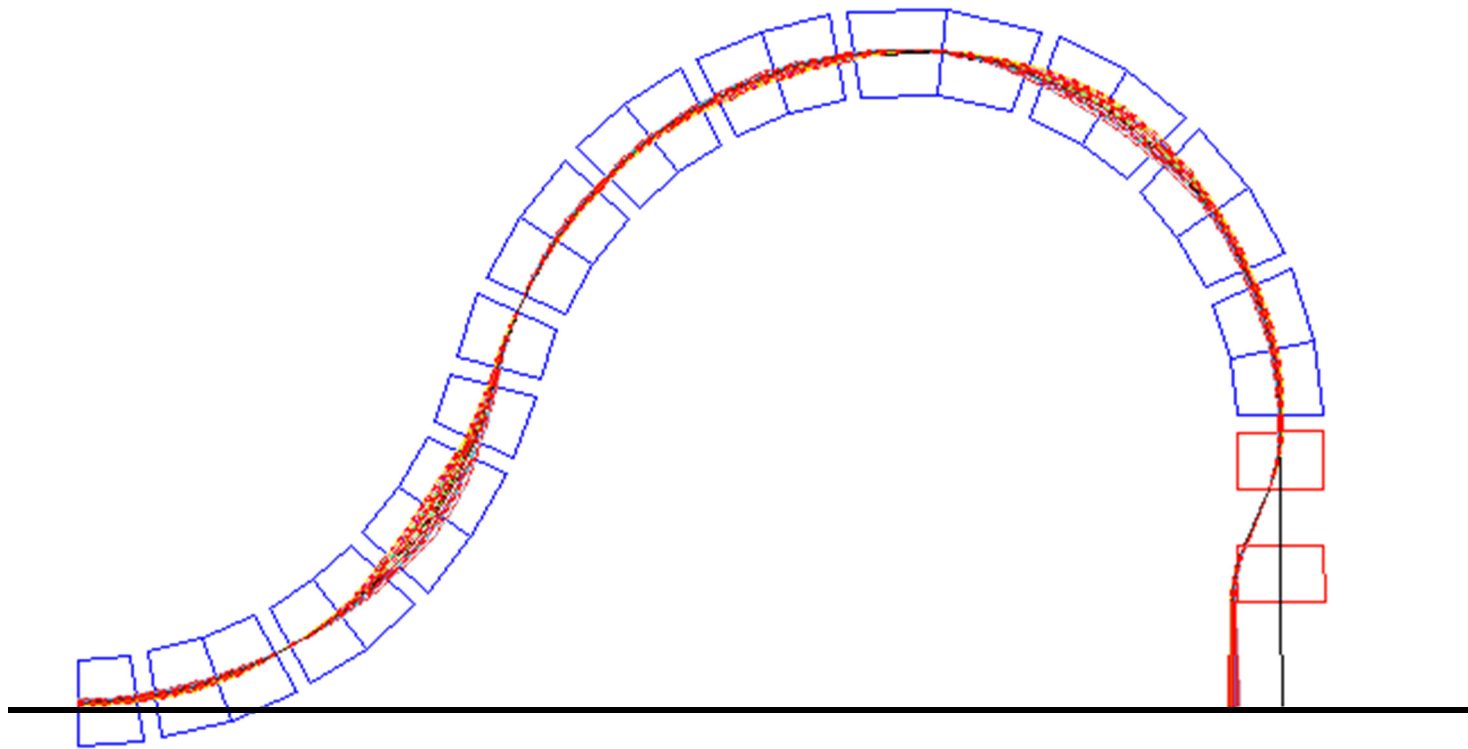

±10 cm
Magnification 5X

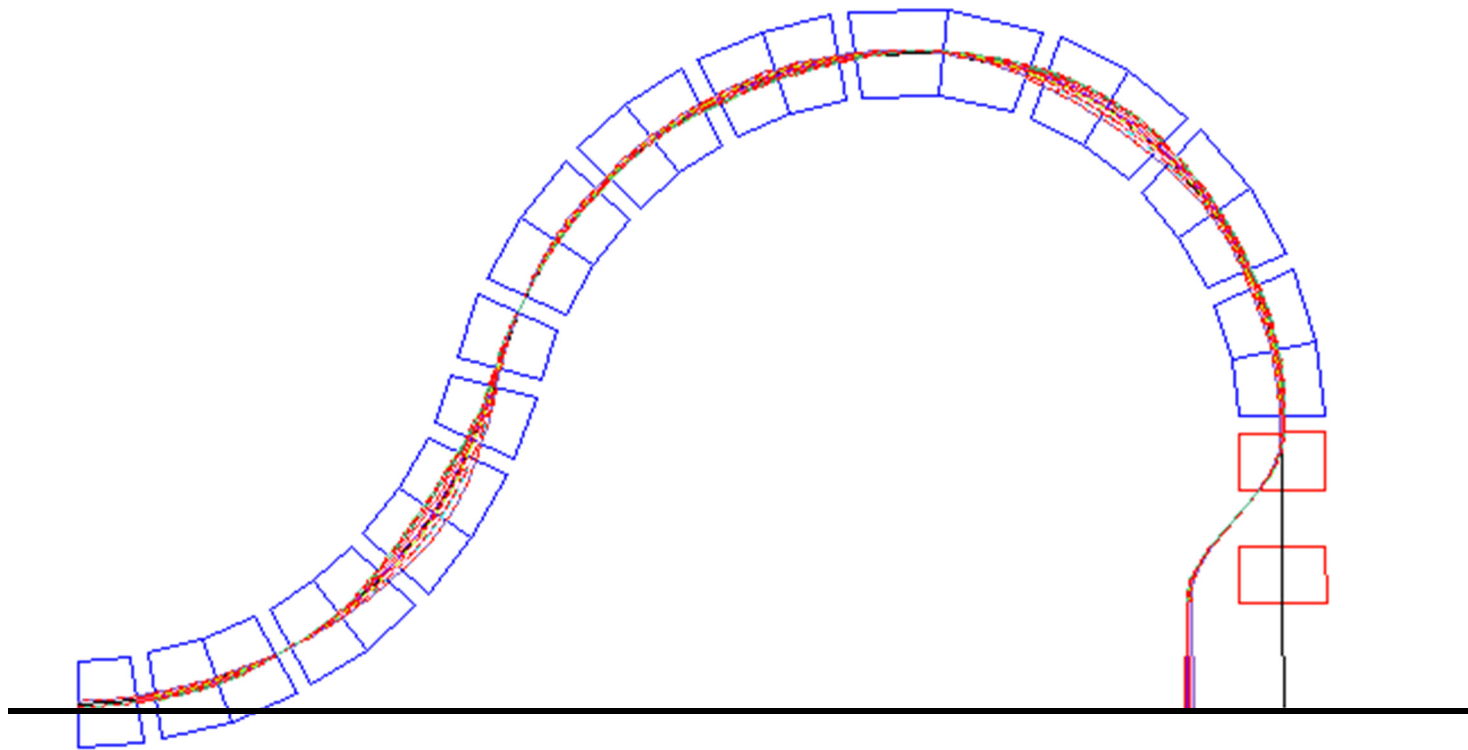

±10 cm
Magnification 5X

State of the Art Gantry at Heidelberg

Weight of the transport components – 135 tons

Total weight = 630 tons - 19 m long. WEIGHT and SIZE

State of the Art Gas

Weight of the transport component

Total weight = 630 tons - 19 m



State of the Art Gantry at Heidelberg

Weight of the transport components – 135 tons

Total weight = 630 tons - 19 m long. WEIGHT and SIZE

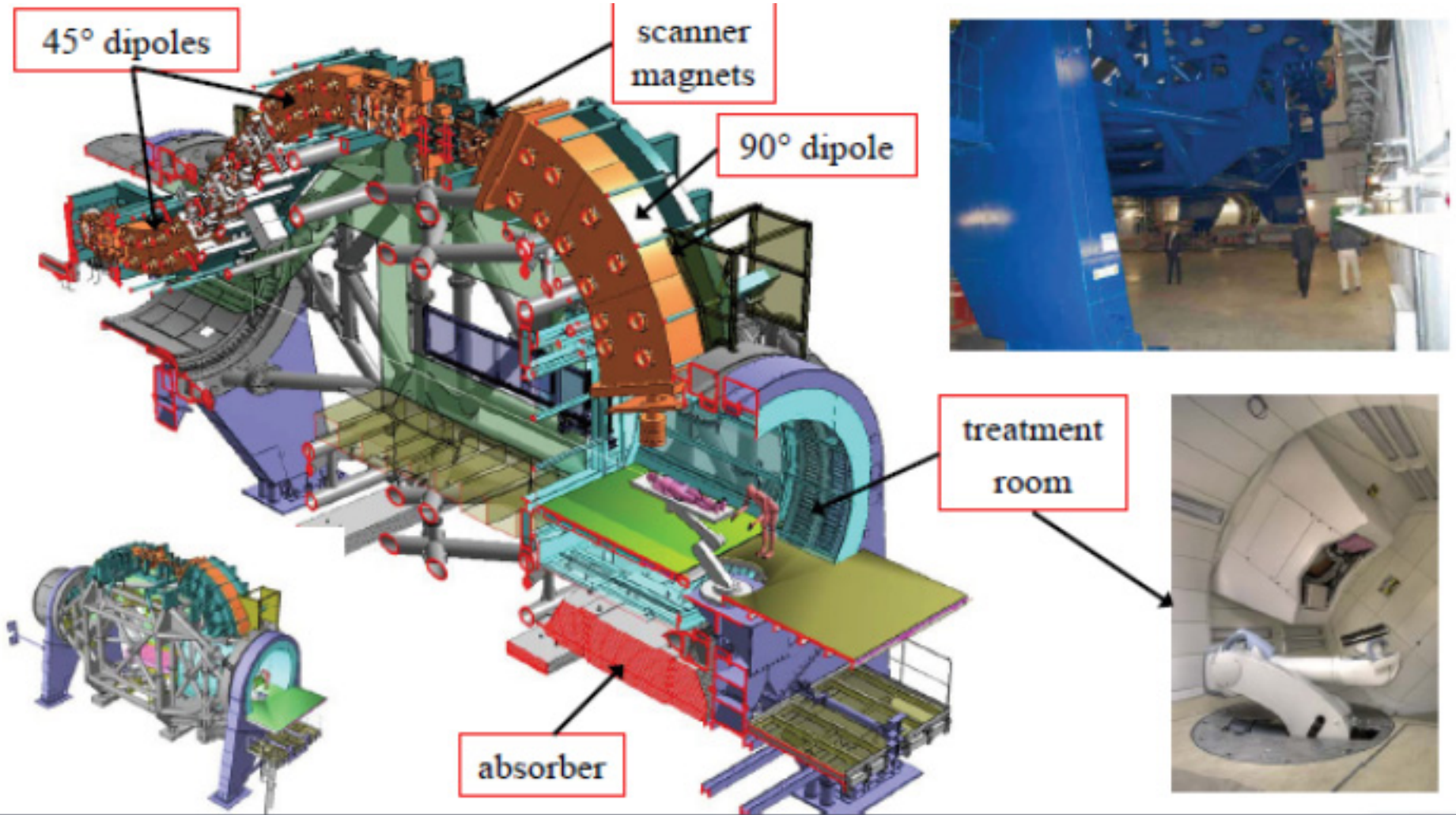



US 20070262269A1

(19) United States

(12) Patent Application Publication (10) Pub. No.: US 2007/0262269 A1
(43) Pub. Date: Nov. 15, 2007

(54) GANTRY FOR MEDICAL PARTICLE THERAPY FACILITY

(75) Inventor: Dejan Trbojevic, Flanders, NY (US)

Correspondence Address:
BROOKHAVEN SCIENCE ASSOCIATES/
BROOKHAVEN NATIONAL LABORATORY
BLDG. 475D - P.O. BOX 5000
UPTON, NY 11973 (US)

(73) Assignee: Brookhaven Science Associates, LLC.

(21) Appl. No.: 11/433,644

(22) Filed: May 12, 2006

Publication Classification

(51) Int. Cl. A61N 5/10 (2007.01)
(52) U.S. CL. 250/492.3; 250/398; 250/396 ML

(57) **ABSTRACT**
A particle therapy gantry for delivering a particle beam to a patient includes a beam tube having a curvature defining a particle beam path and a plurality of fixed field magnets sequentially arranged along the beam tube for guiding the particle beam along the particle path. In a method for delivering a particle beam to a patient through a gantry, a particle beam is guided by a plurality of fixed field magnets sequentially arranged along a beam tube of the gantry and the beam is alternately focused and defocused with alternately arranged combined function focusing and defocusing fixed field magnets.

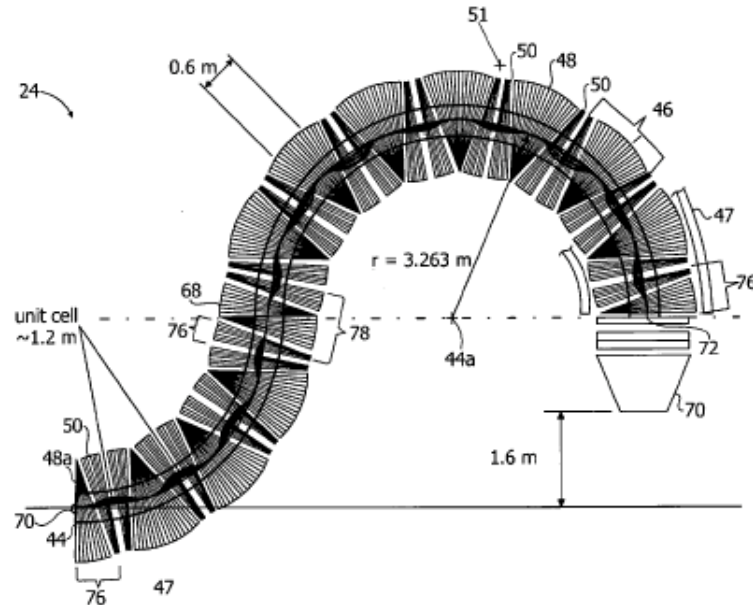

2. TITLE OF INVENTION

Innovative Scanning System for the ion cancer therapy

- a. GENERAL DESCRIPTION. Outline briefly what your invention is about and the manner in which the advantages of your invention are achieved. If it is only a part of a larger system that includes known components, concentrate on the new development. If pertinent, attach illustrations and refer to them in the description. Please address the following issues:
 - i. What is the problem to be solved?
 - ii. What prior attempts were used to solve the problem?
 - iii. What are the disadvantages or shortcomings of previous attempts to solve the problem?
 - iv. How does the invention work?
 - v. Give a detailed description of the invention.
 - vi. Describe known variants of the invention.
 - vii. What further development remains to be accomplished?

If more space is needed, attach a sheet.

Number of the hadron cancer therapy facilities in the world has an exponential growth due to clear advantages with respect to any other radiation treatment. Deposited ion energy in the patient body is localized in the Bragg peak precisely in the cancerous tumor without affecting living cells around. The transverse spot scanning system (TSSS) moves the beam to cover tumor transverse size ±10 cm, while the selected energy defines the longitudinal position of the Bragg peak.

DIMENSIONS of the CARBON GANTRY

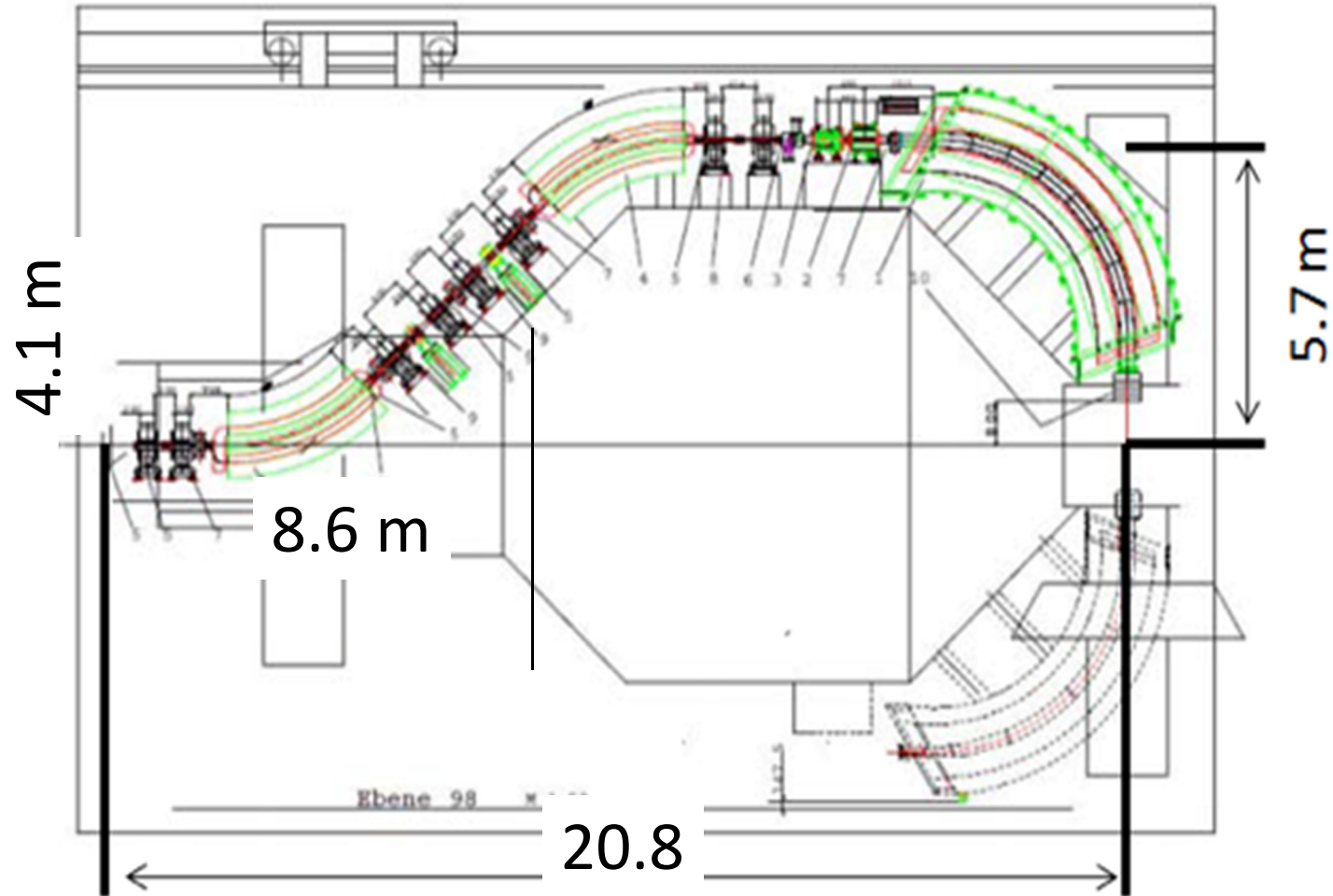

Carbon $E_k = 400 \text{ MeV/u} \rightarrow B\rho = 6.35 \text{ Tm} \quad (\theta = Bl/B\rho)$

Warm iron magnets:

$B = 1.6 \text{ T}$ then $\rho \sim 4.0 \text{ m}$

Superconducting magnets

$B = 3.2 \text{ T}$ then $\rho \sim 2.0 \text{ m}$

DIMENSIONS of the CARBON GANTRY

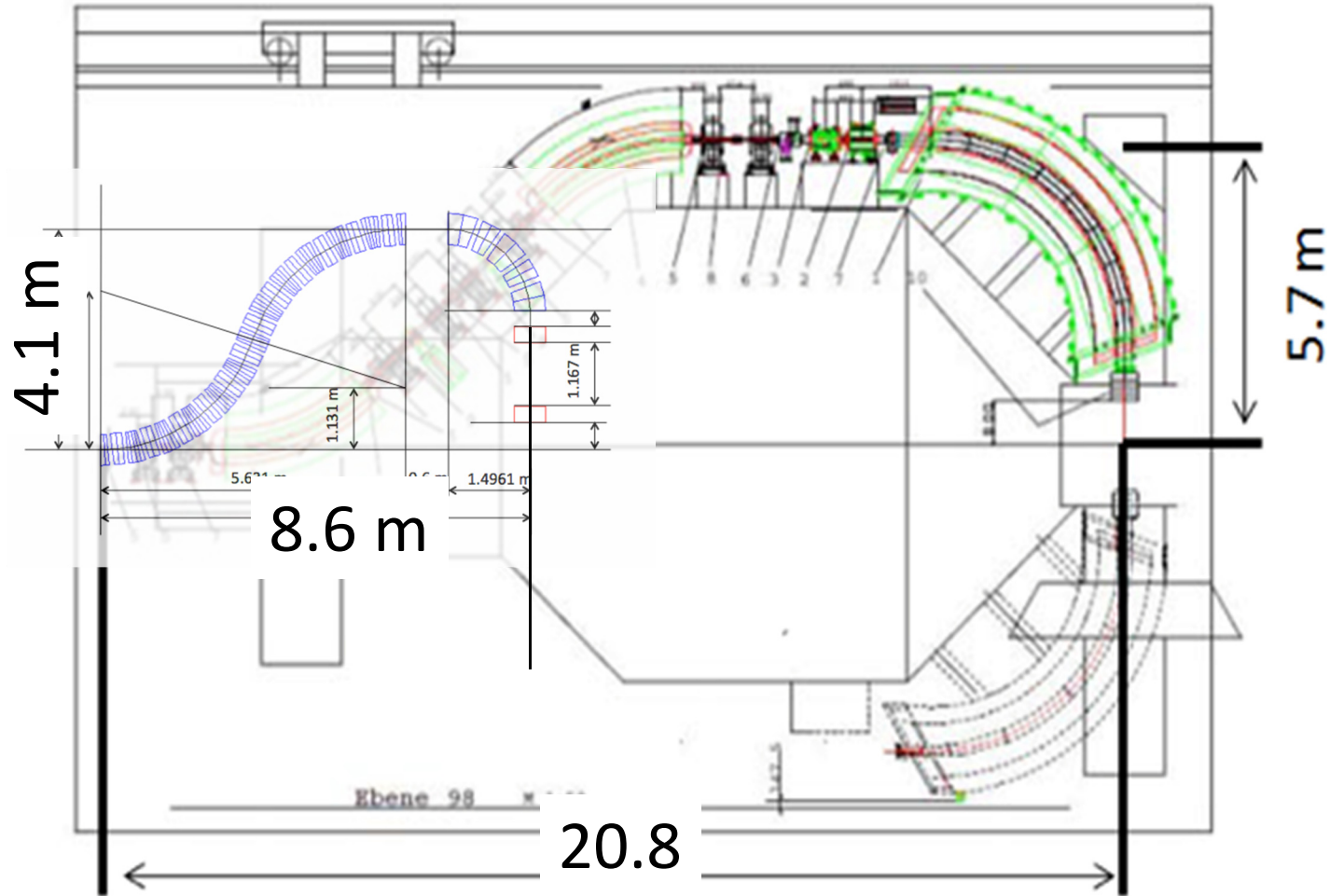

Carbon $E_k=400 \text{ MeV/u} \rightarrow B\rho = 6.35 \text{ Tm} (\theta = Bl/B\rho)$

Warm iron magnets:

$B=1.6 \text{ T}$ then $\rho \sim 4.0 \text{ m}$

Superconducting magnets

$B=3.2 \text{ T}$ then $\rho \sim 2.0 \text{ m}$

Tracking particles in the carbon gantry for the energy range of 190-400 MeV/u

collaboration with Vasily Morozov-Jefferson Lab for the six gradients adjustment

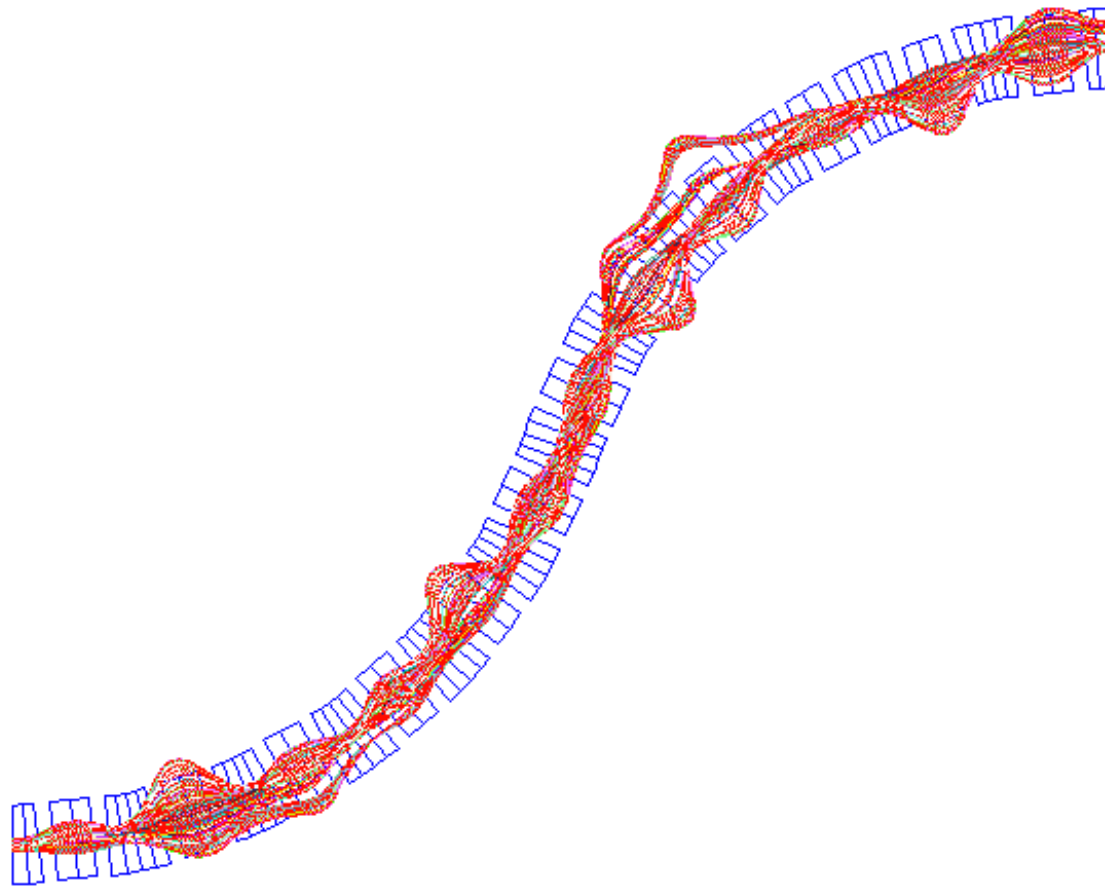

All at once: Fixed field & fixed focusing

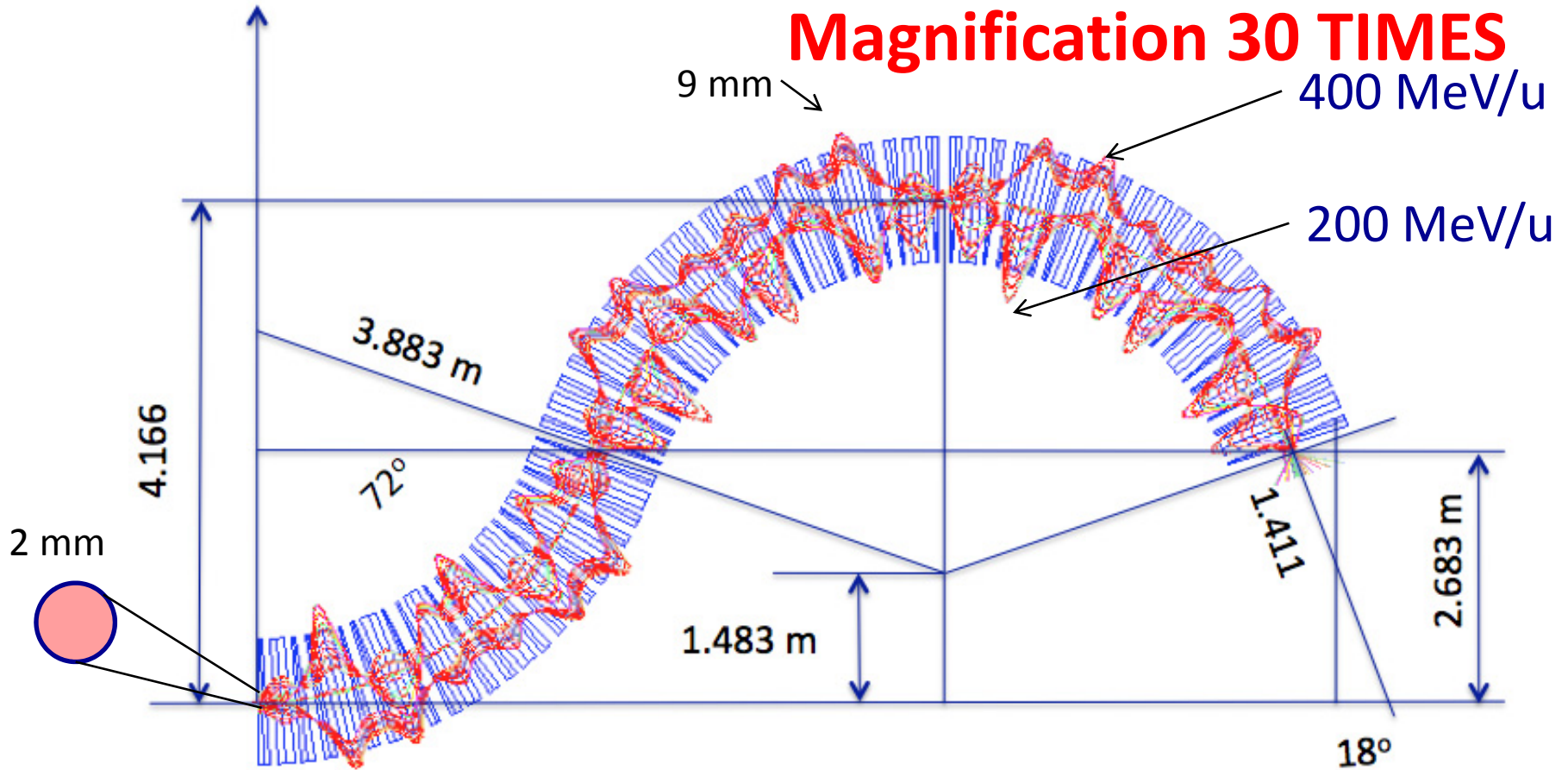

Reducing the size and weight of the carbon gantry (135 tons → 2 tons) and simplifying operation

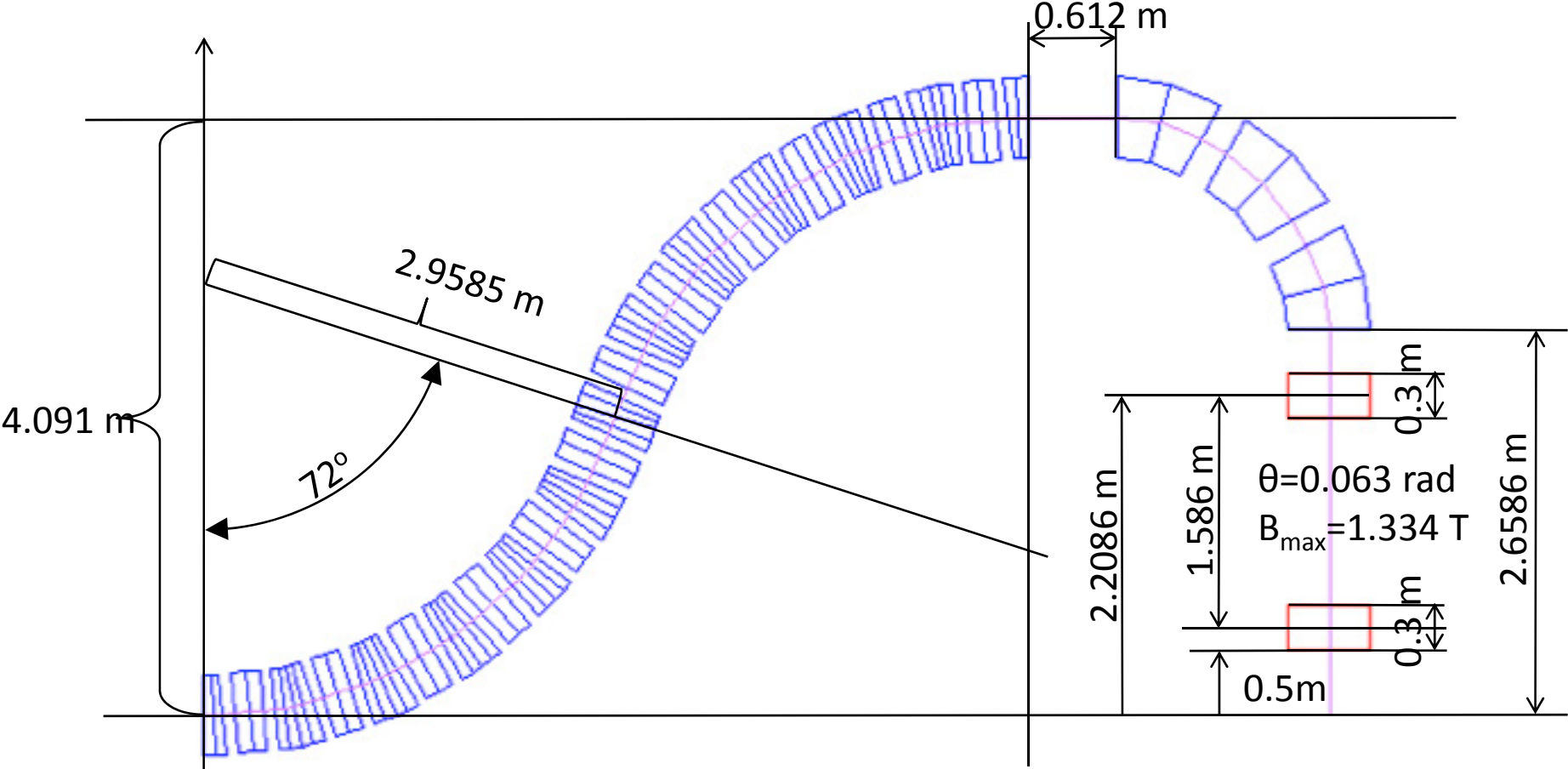

Amplitude functions in the carbon gantry

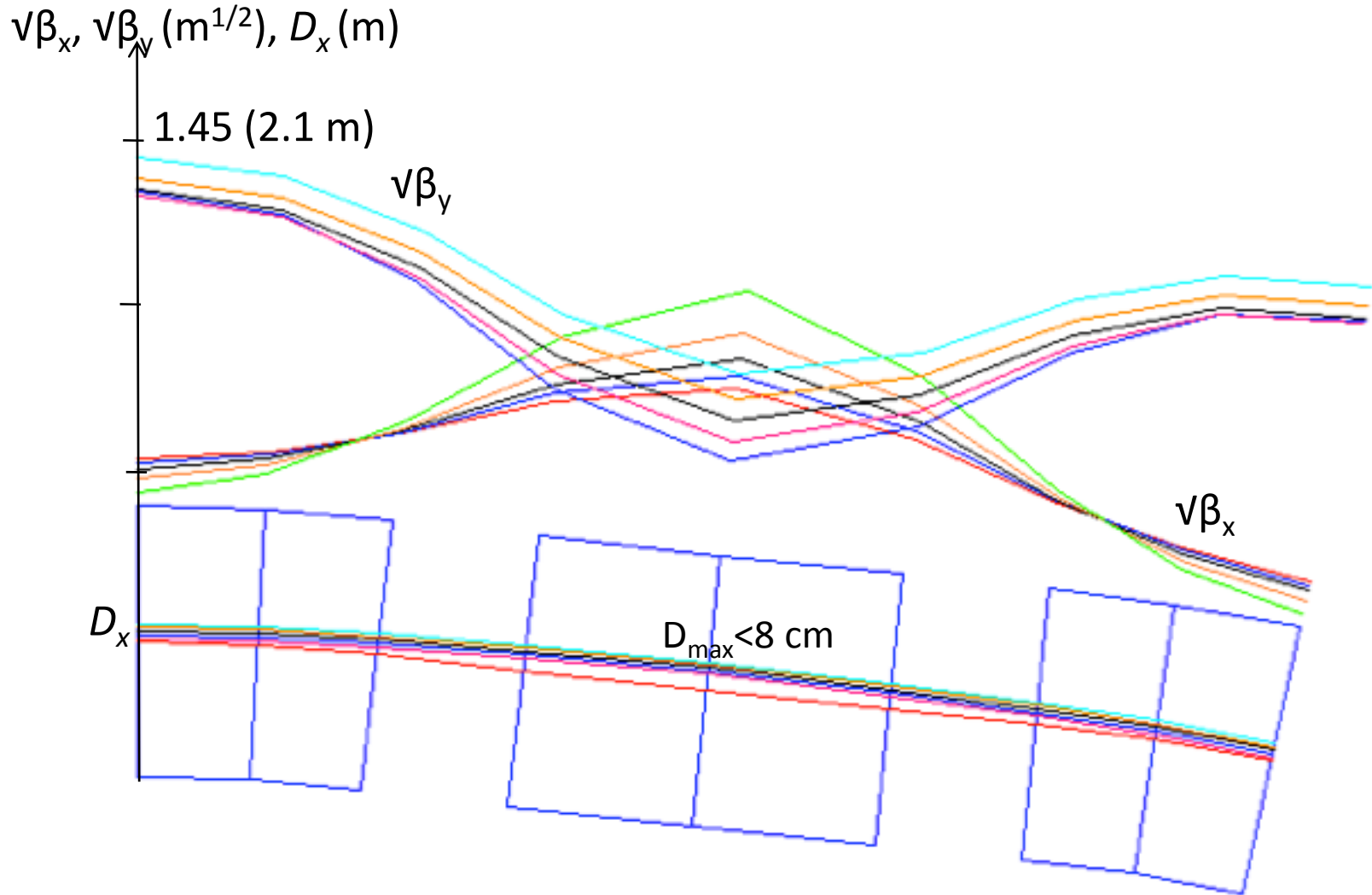

CARBON GANTRY $h=4.091\text{m}$ without magnification

$$\theta = Bl/6.$$
$$l = 0.3\text{m}$$

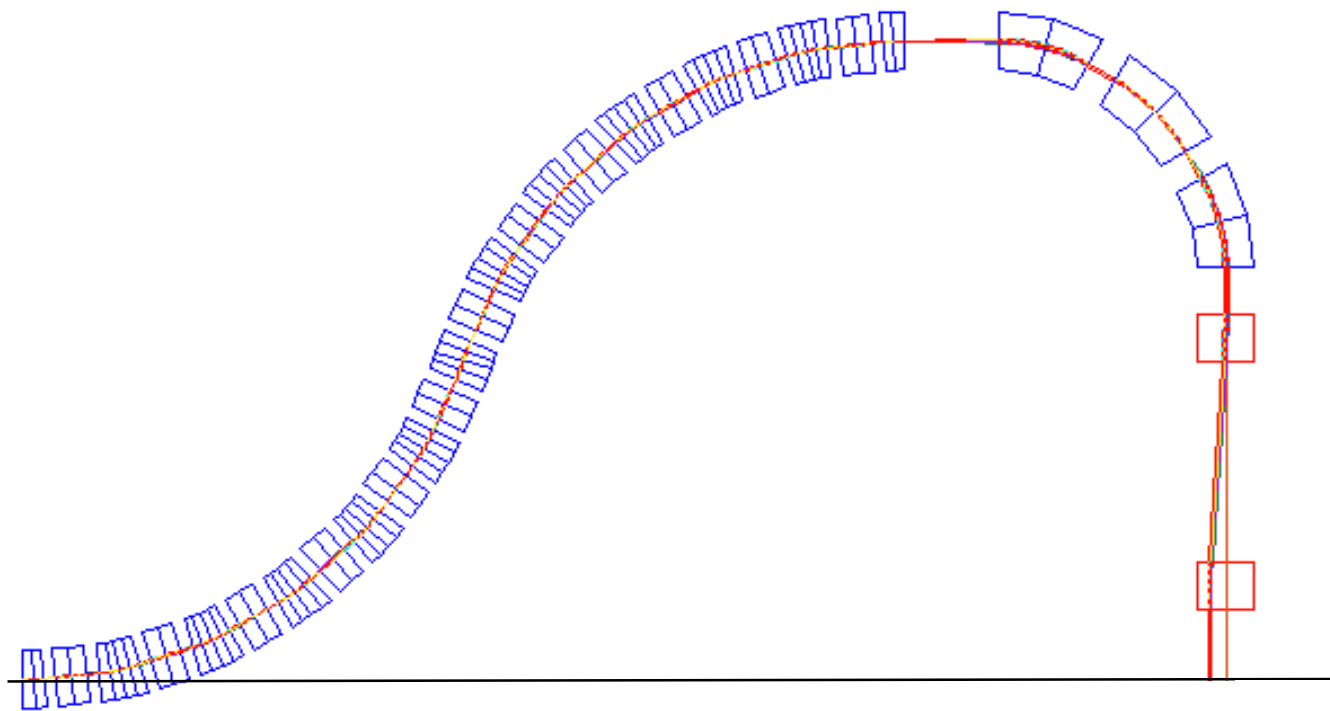

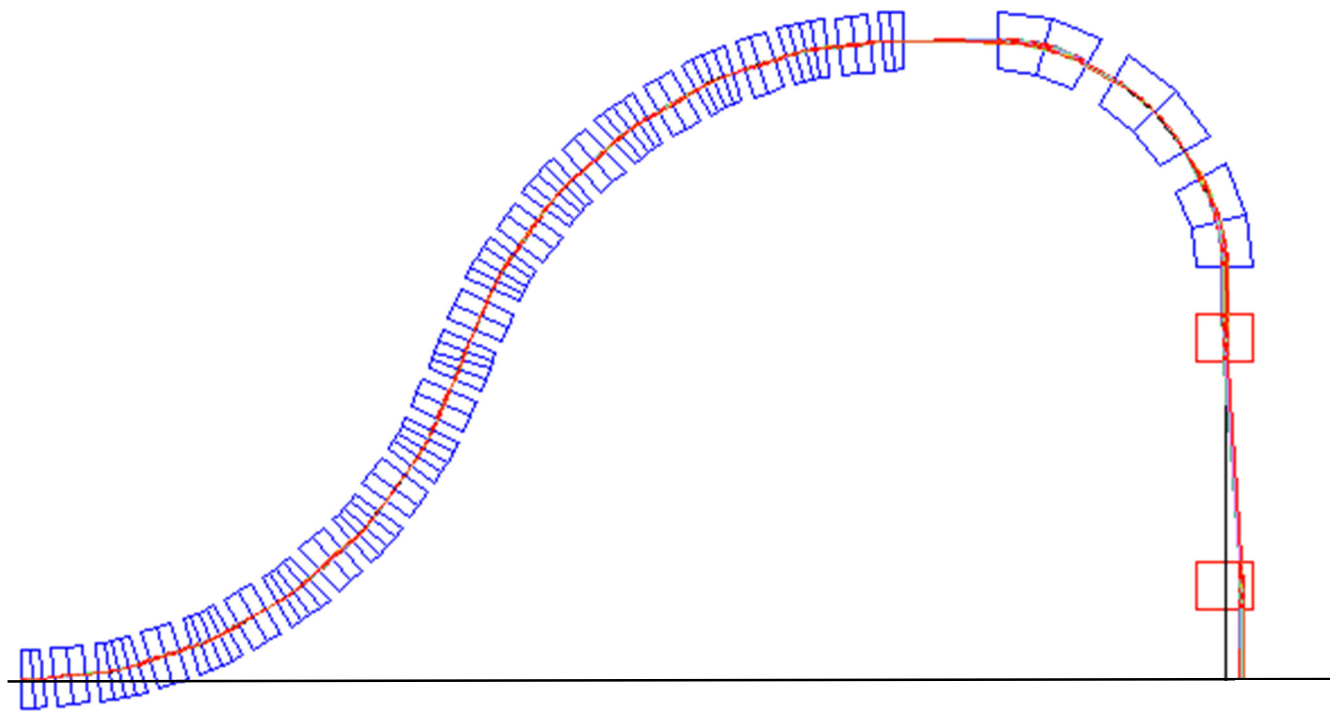

CARBON GANTRY $h=4.091\text{m}$ without magnification

216 MeV/u

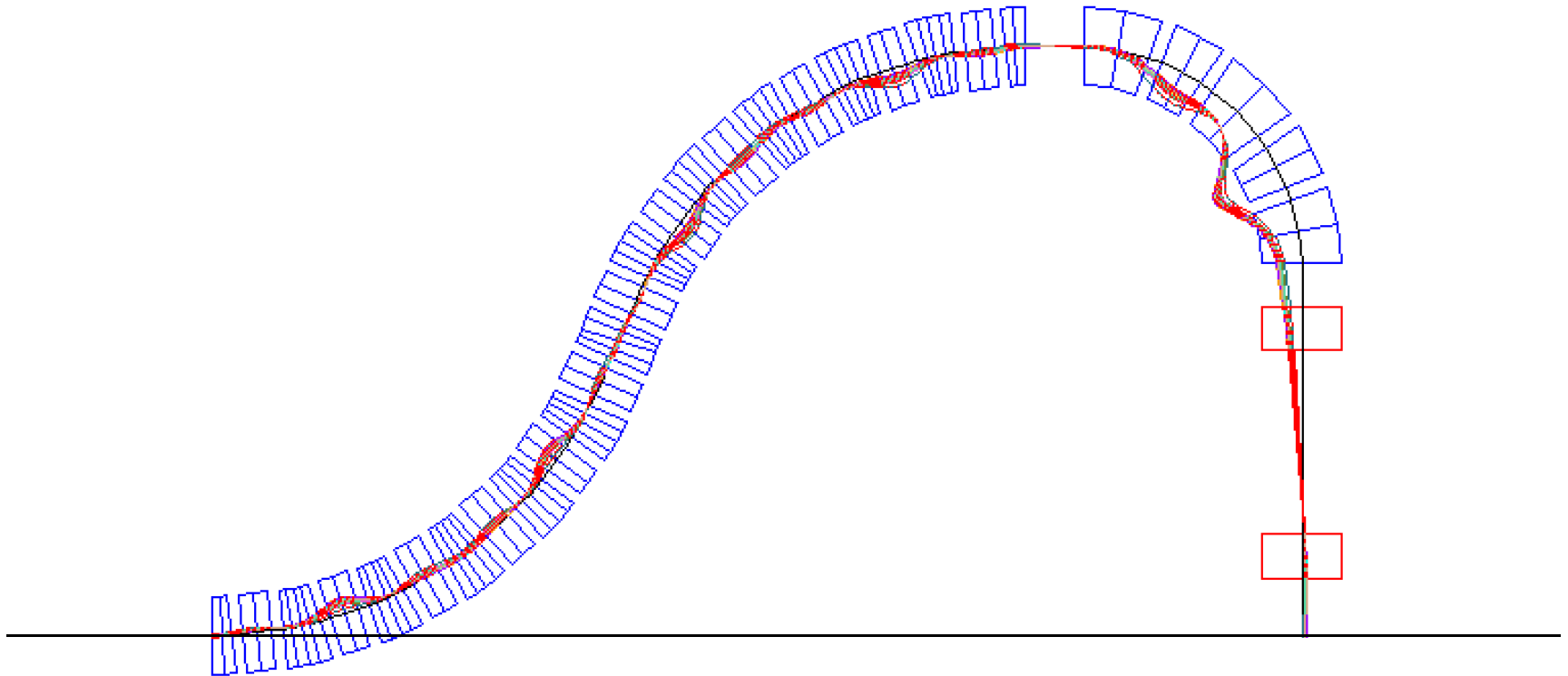

CARBON GANTRY $h=4.091\text{m}$ without magnification

216 MeV/u

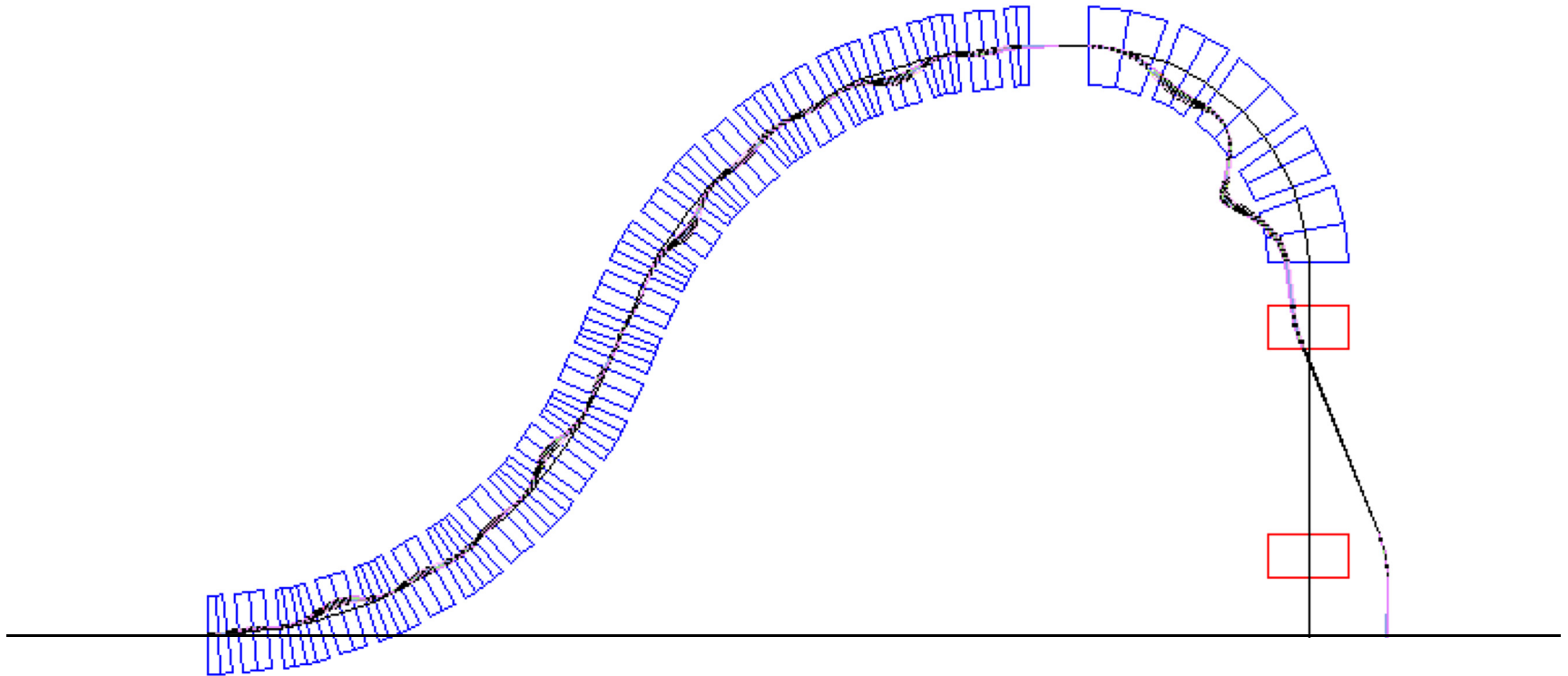

CARBON GANTRY $h=4.091\text{m}$ without magnification

216 MeV/u

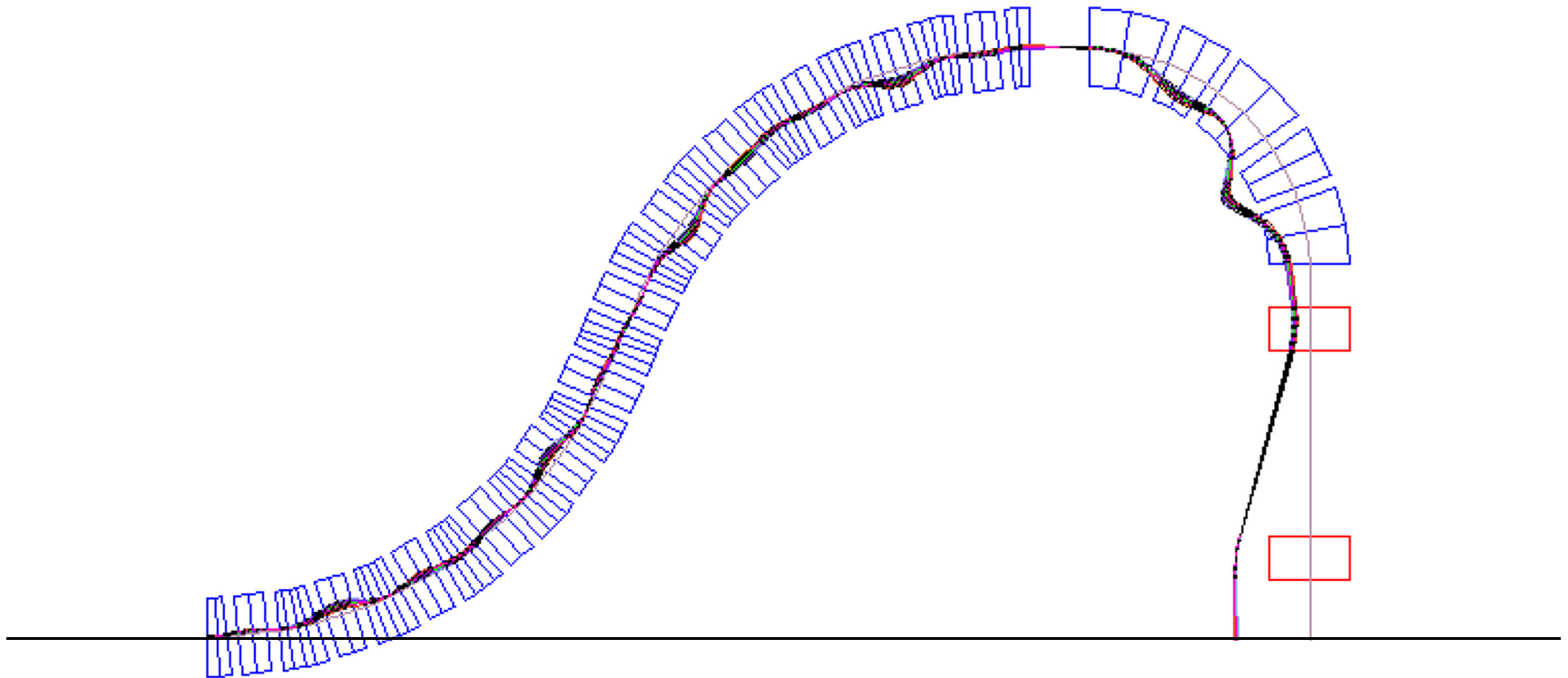

CARBON GANTRY $h=4.091\text{m}$ without magnification

292 MeV/u

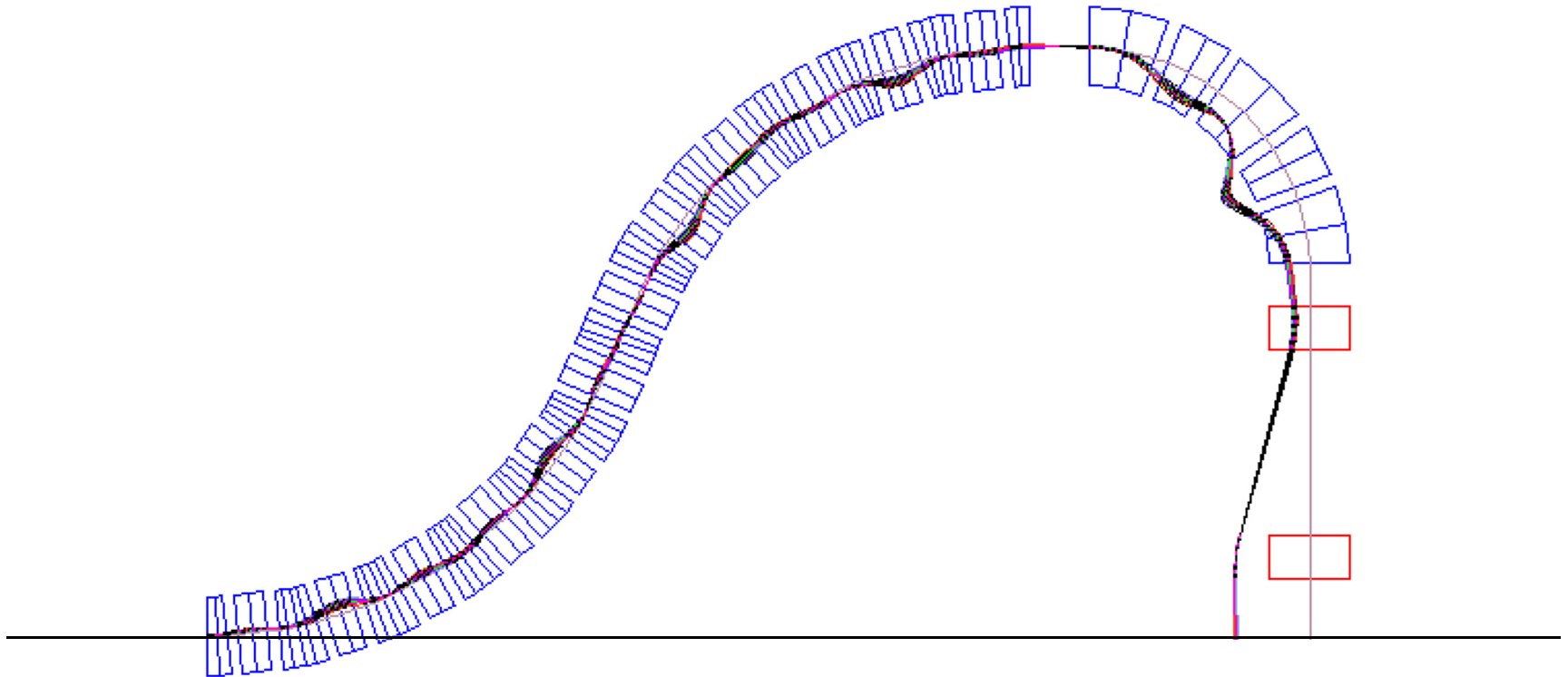

CARBON GANTRY $h=4.091\text{m}$ without magnification

292 MeV/u

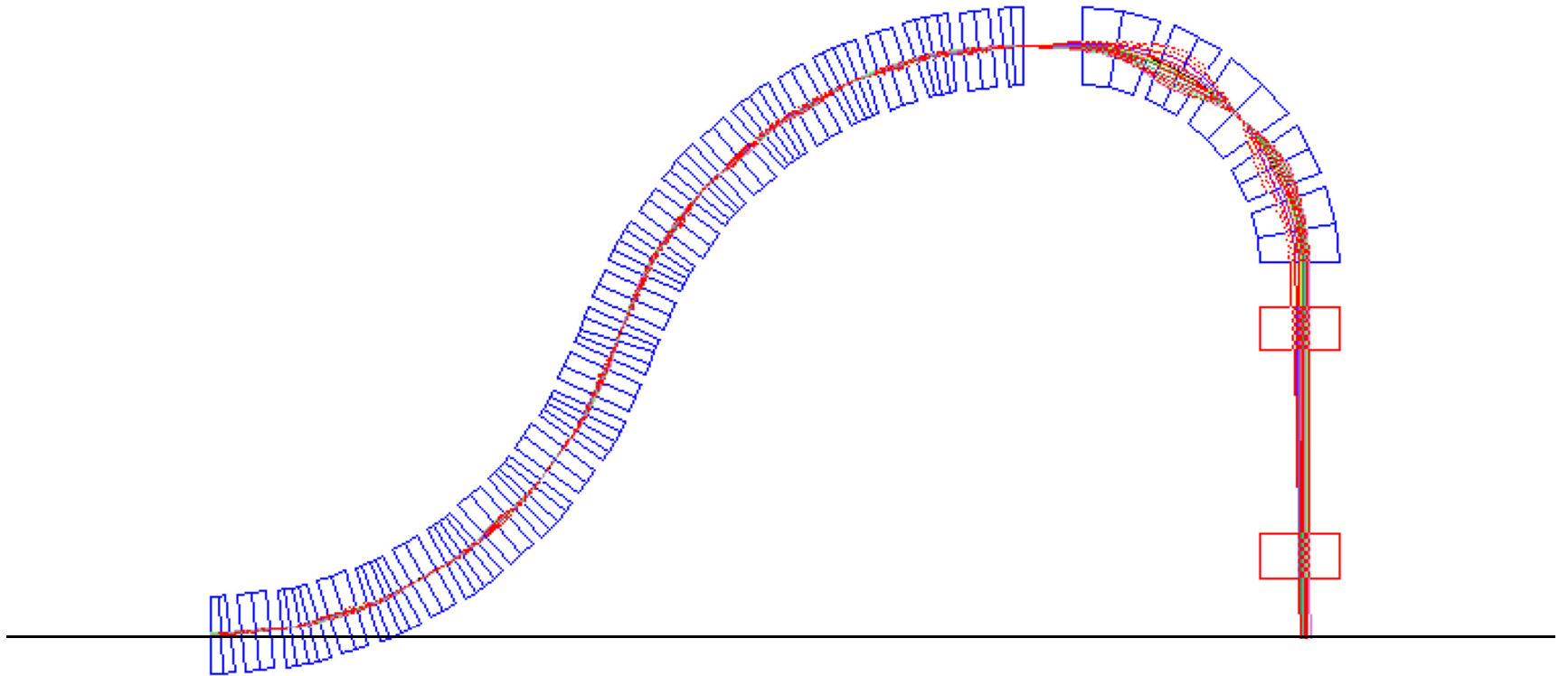

CARBON GANTRY $h=4.091\text{m}$ without magnification

292 MeV/u

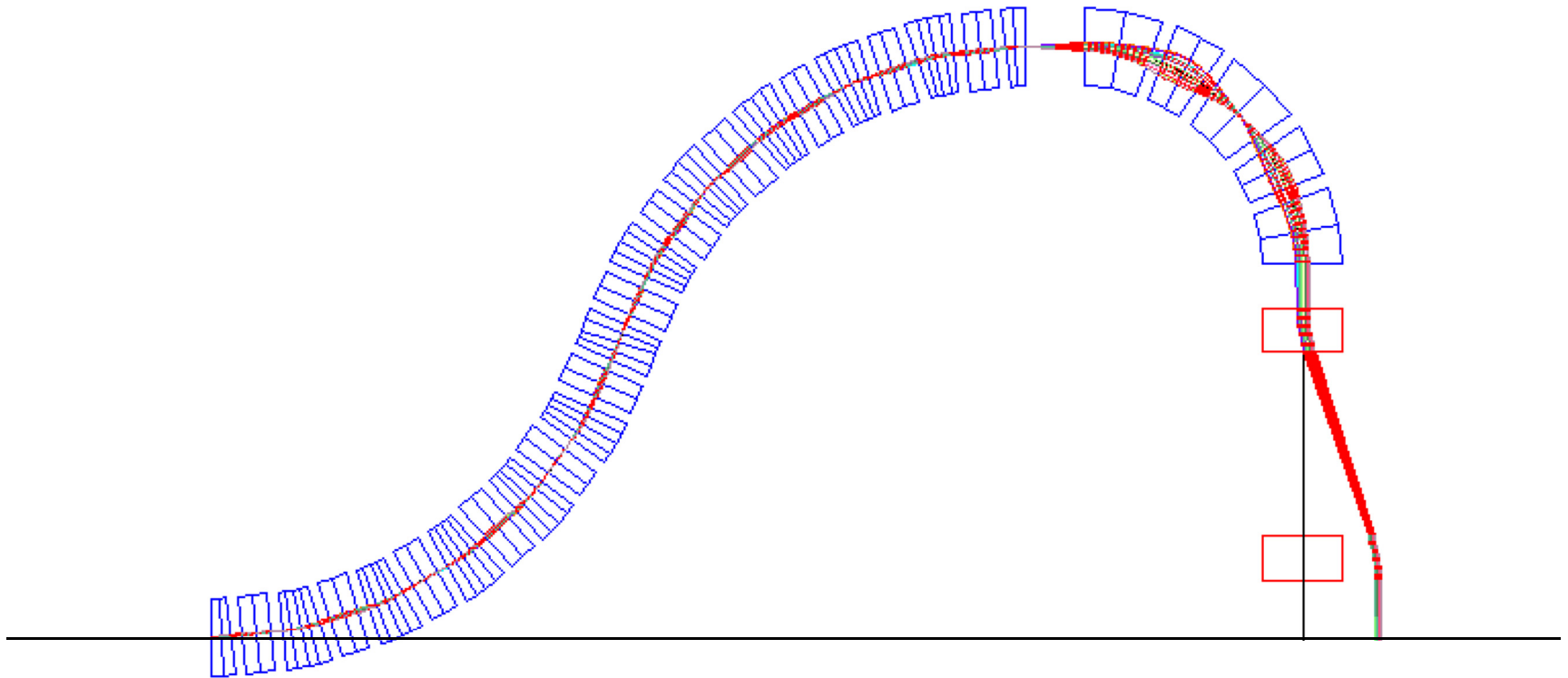

CARBON GANTRY $h=4.091\text{m}$ without magnification

292 MeV/u

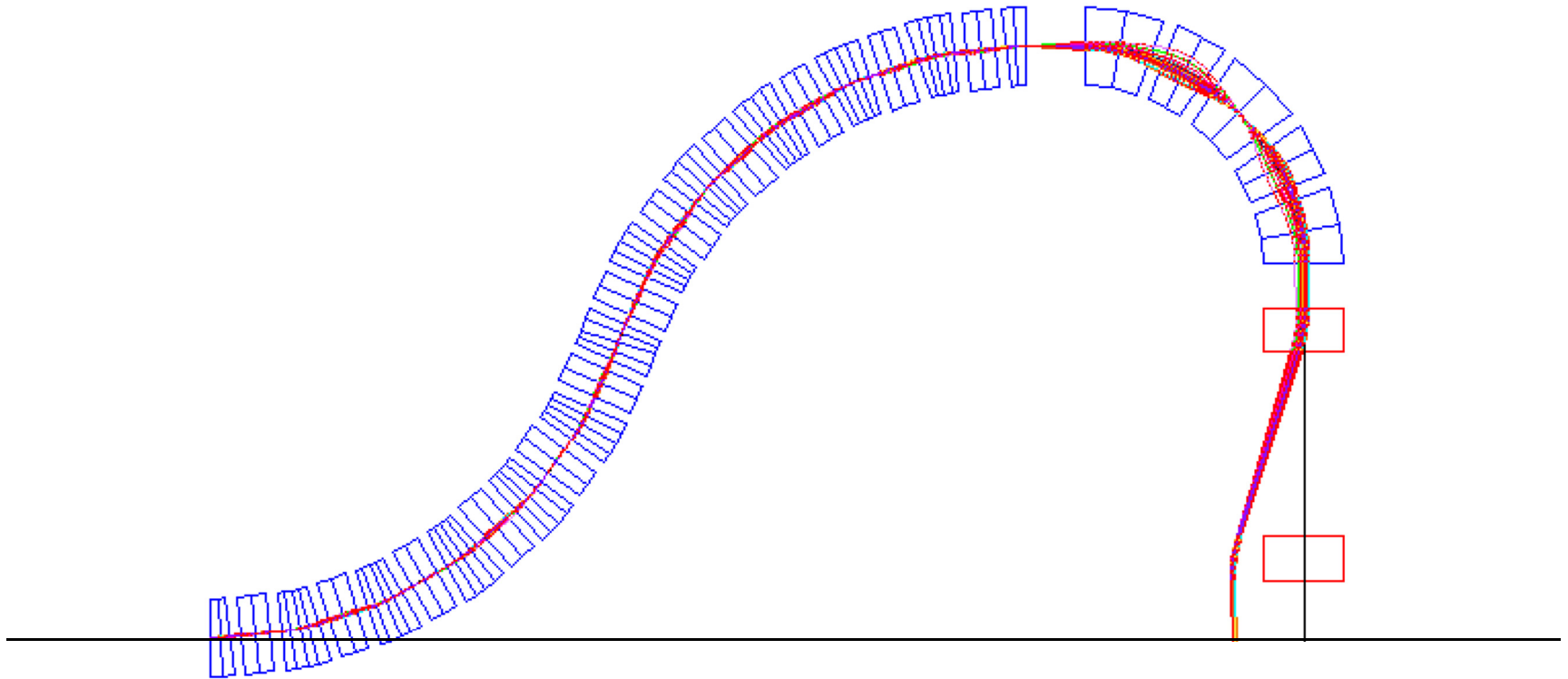

CARBON GANTRY $h=4.091\text{m}$ without magnification

400 MeV/u

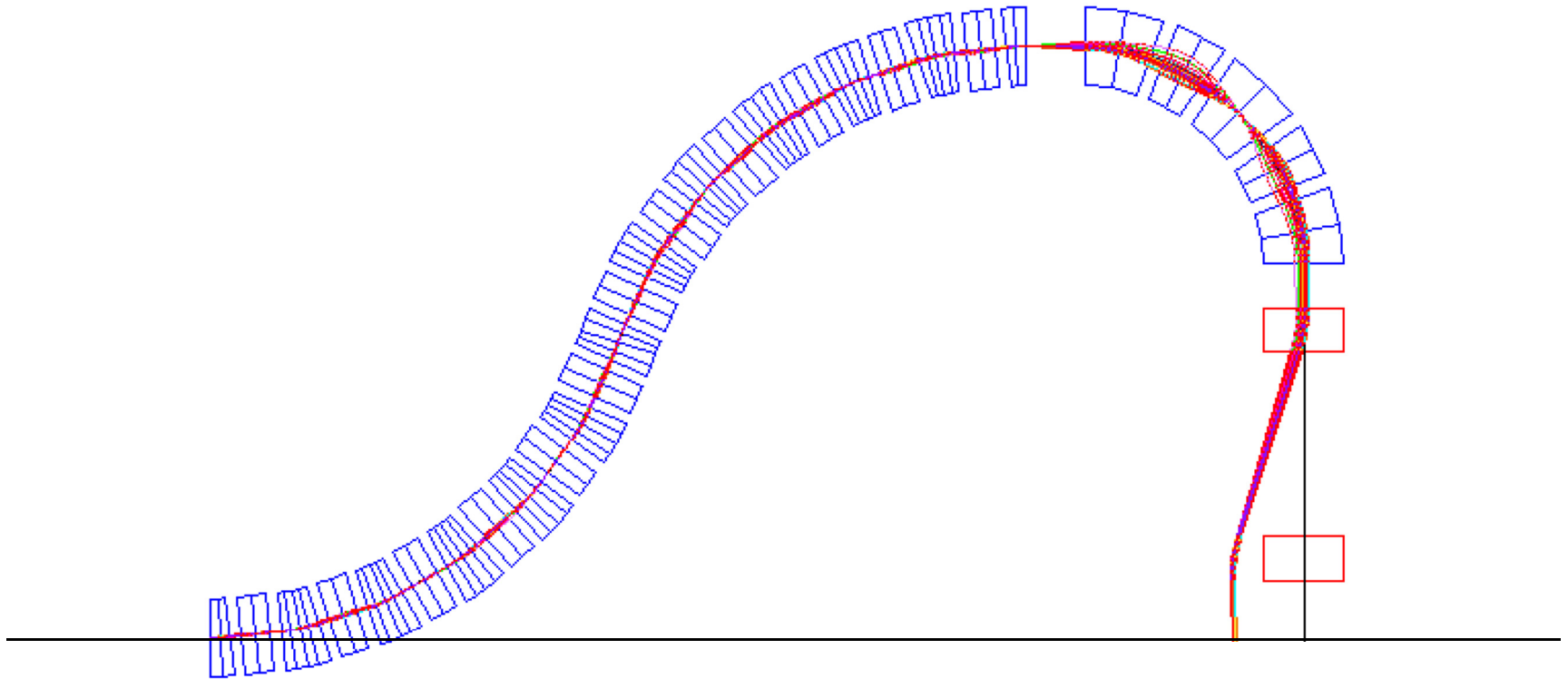

CARBON GANTRY $h=4.091\text{m}$ without magnification

400 MeV/u

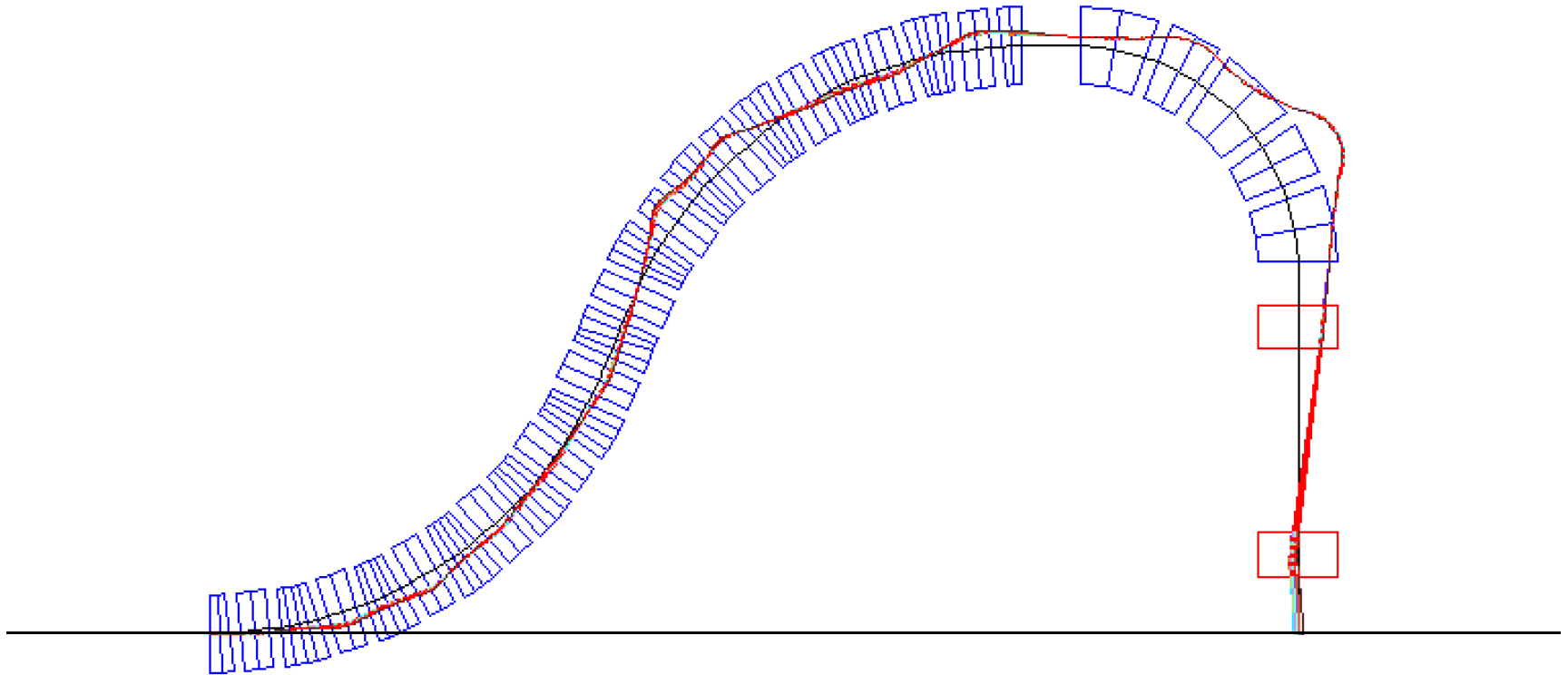

CARBON GANTRY $h=4.091\text{m}$ without magnification

400 MeV/u

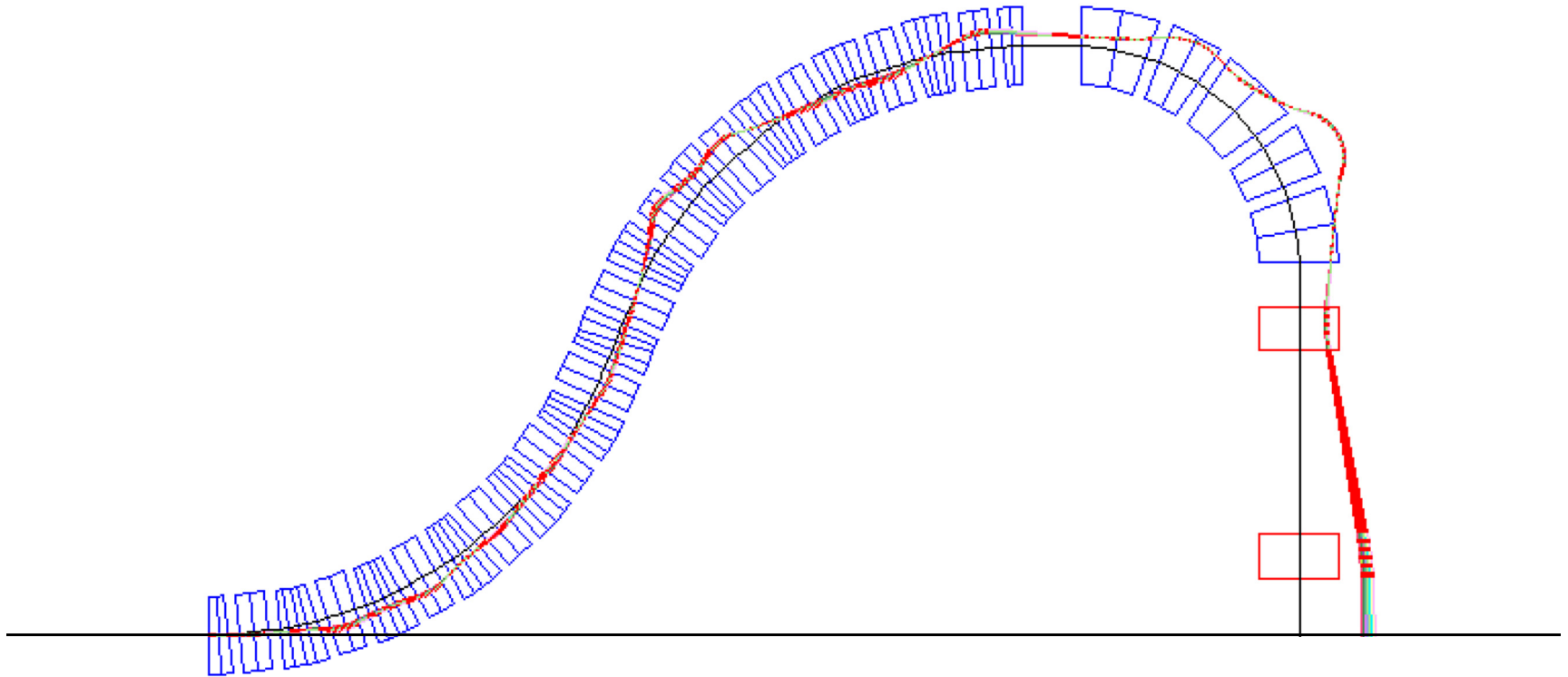

CARBON GANTRY $h=4.091\text{m}$ without magnification

400 MeV/u

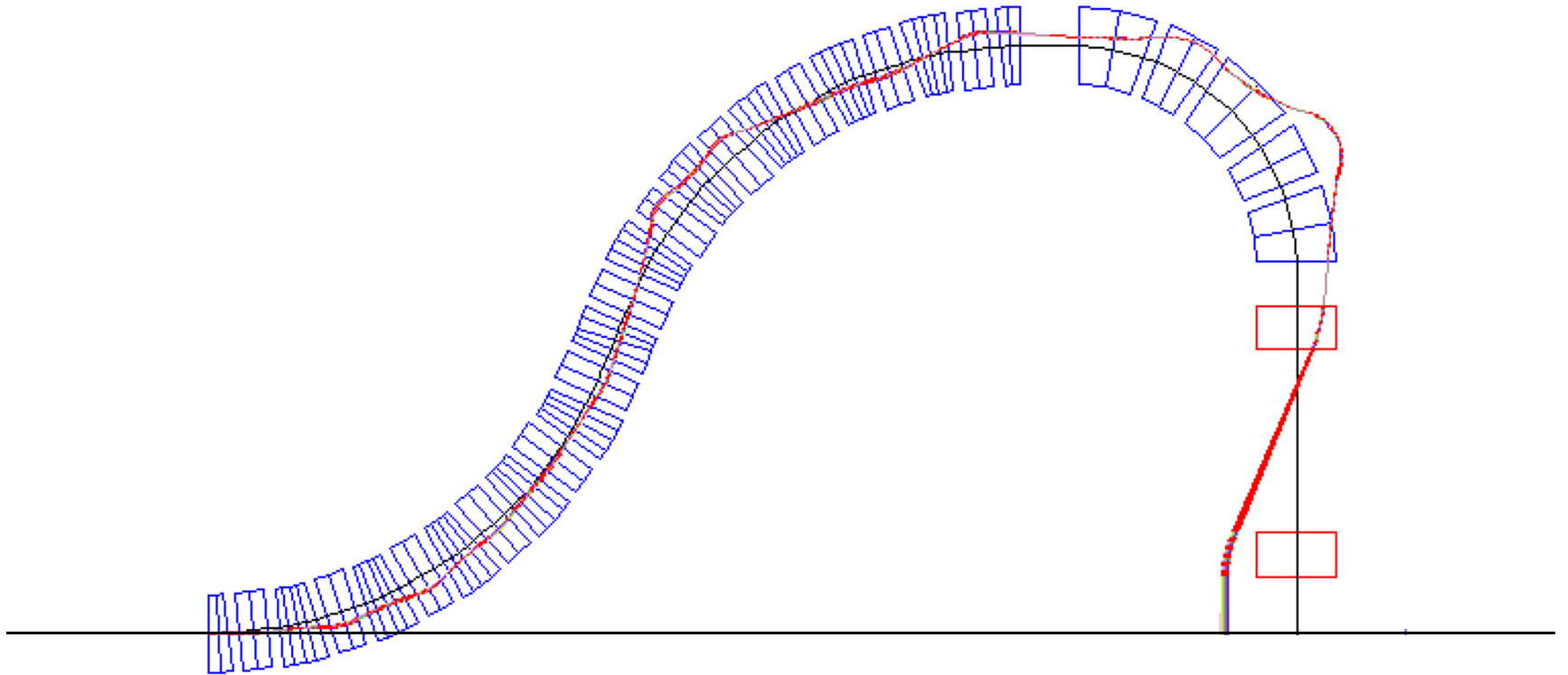

CARBON GANTRY height 4.091m

5X magnification, scanning ± 10 cm

CARBON GANTRY height 4.091m

5X magnification, scanning ± 10 cm

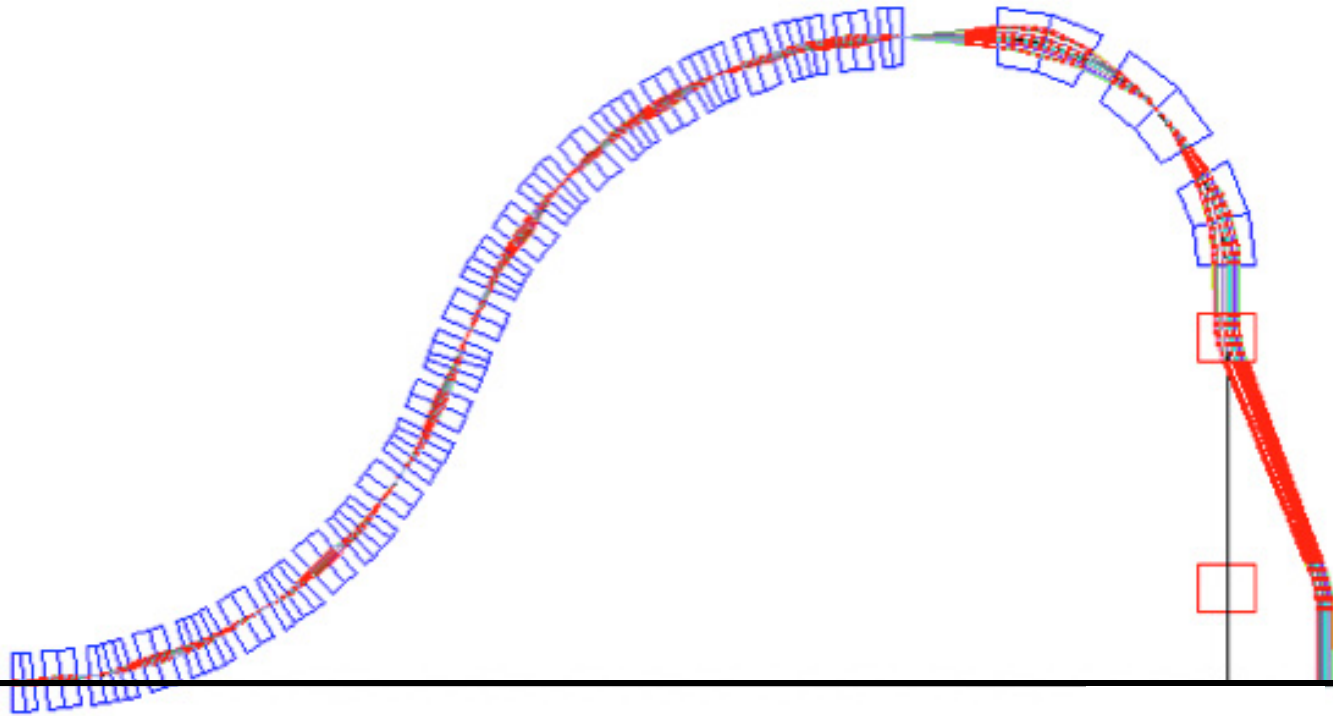

CARBON GANTRY height 4.091m

5X magnification, scanning ± 10 cm

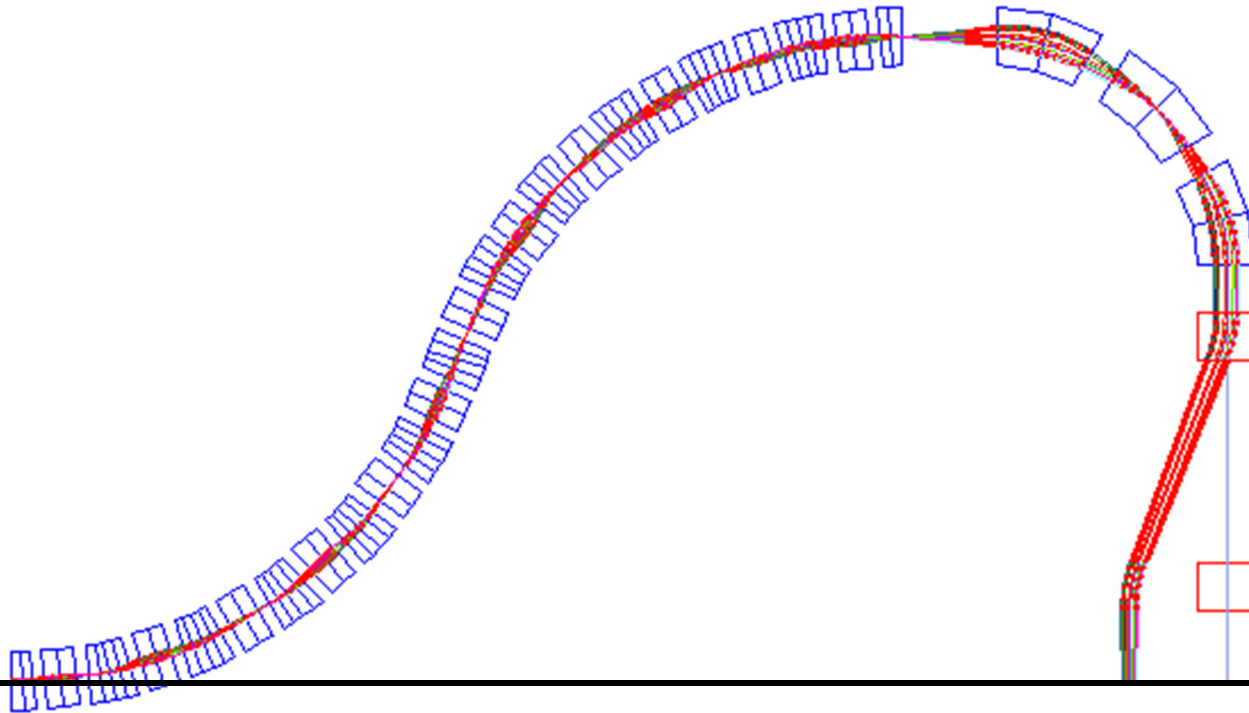

Mobile isocenter - 2

Patient positioned in a small room “somewhere”



Side access, PIMMS

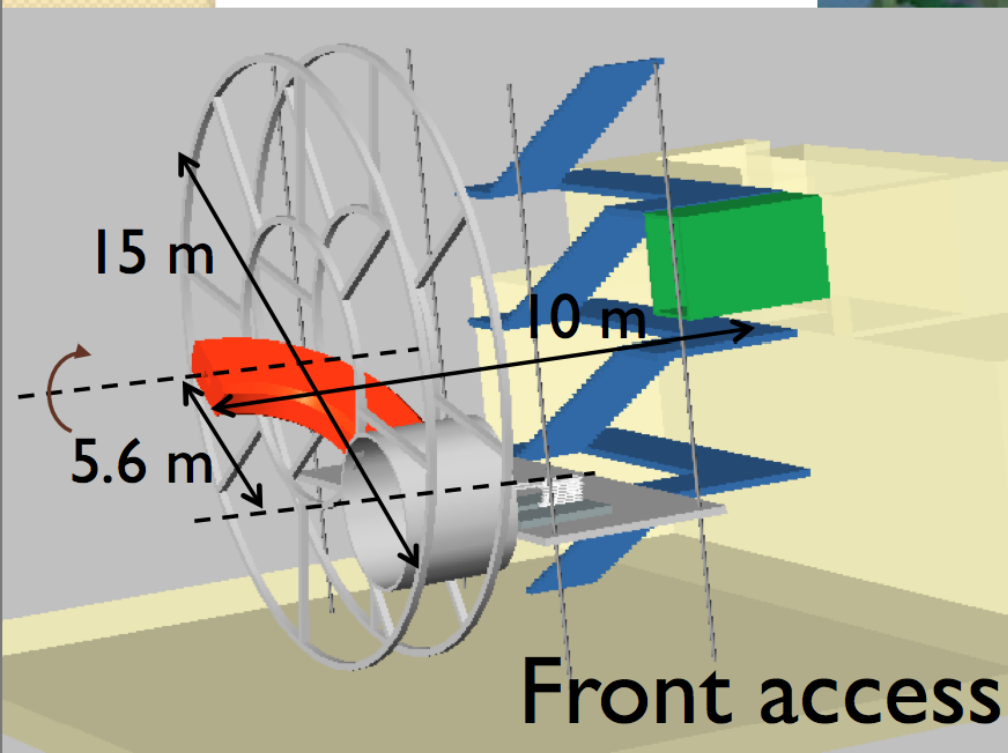

Gantry is longer, than just the last magnet but at small r



The CNAO 90° magnet during installation in the vertical line. The size is the same as for a gantry final magnet.

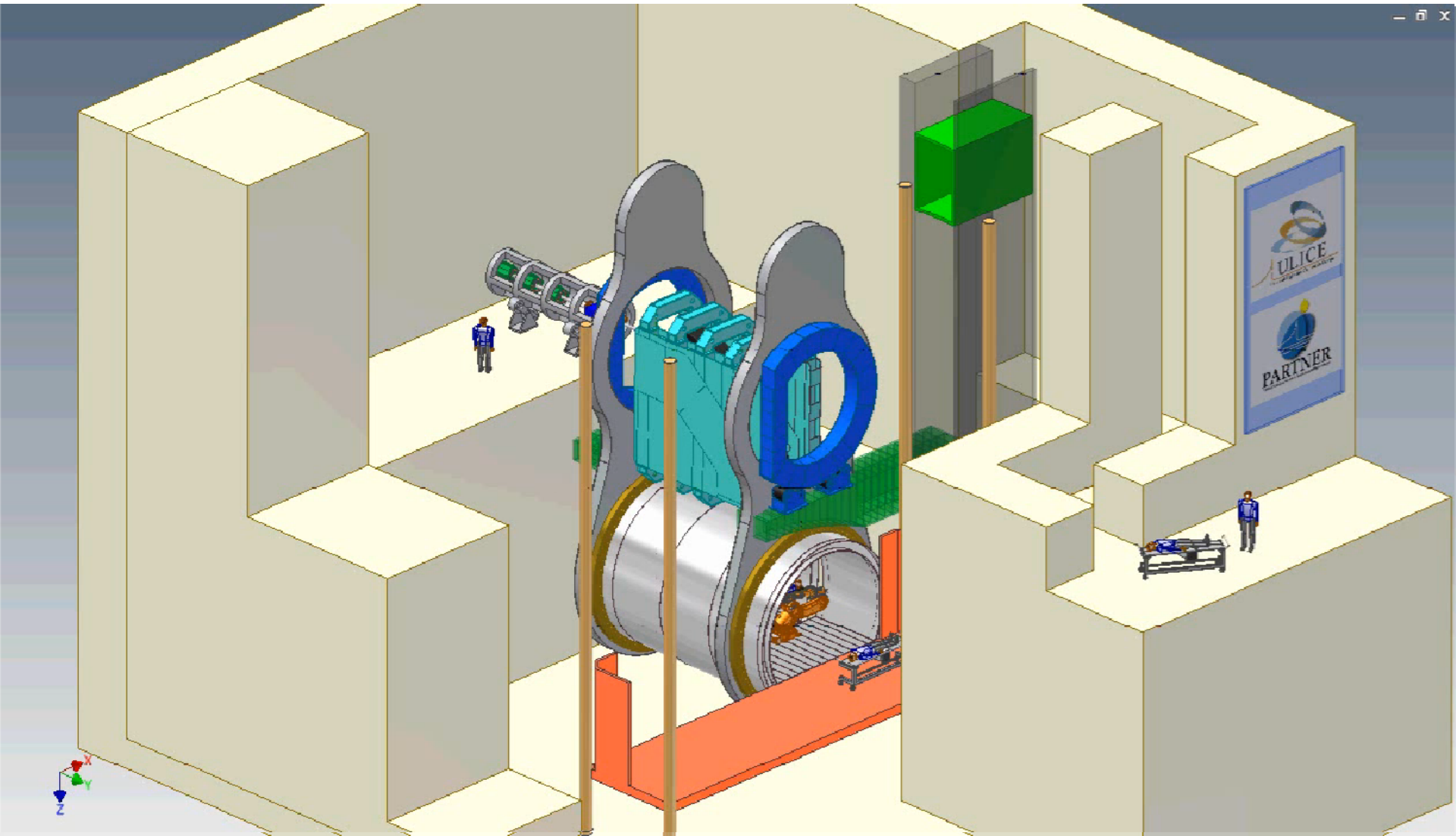

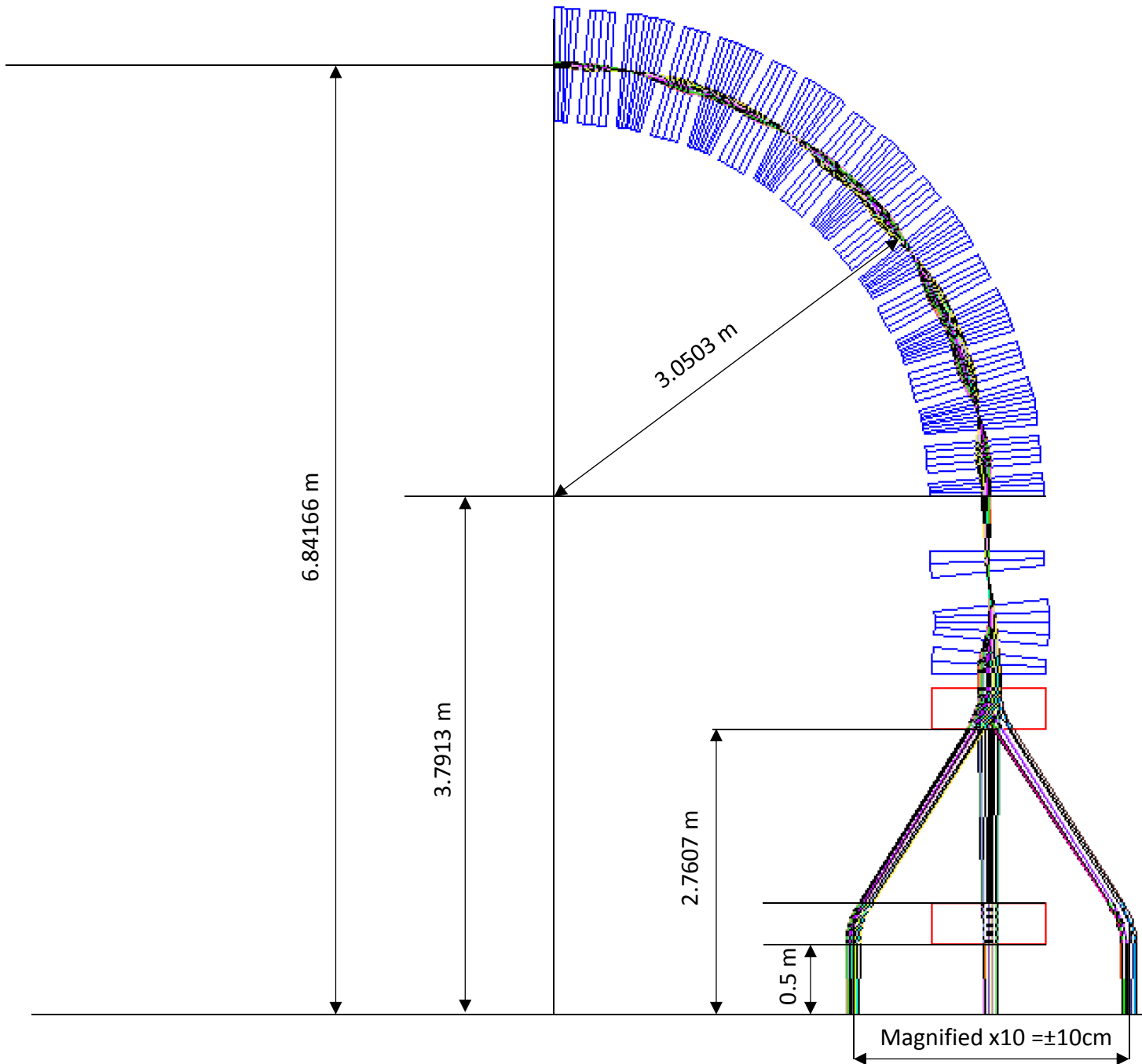

KINETIC ENERGY
202.6 MeV/u

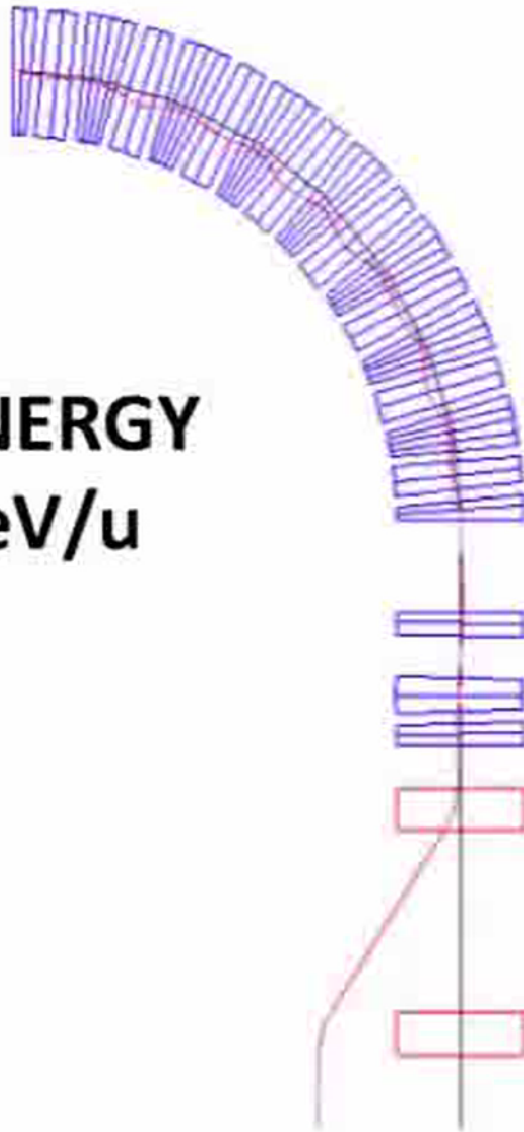

Magnetic field required in the pipe and estimated maximum field in the coils

$$B_{D \max} = B_d + G_D x = 4.56 - 90.8 * \begin{cases} 9.7 \text{ mm} & 3.67 \text{ T} \\ -6.75 \text{ mm} & 5.63 \text{ T} \end{cases}$$

$$B_{F \max} = B_f + G_F x = -0.385 + 152 * \begin{cases} 20.0 \text{ mm} & 2.34 \text{ T} \\ -13.75 \text{ mm} & -3.4 \text{ T} \end{cases}$$

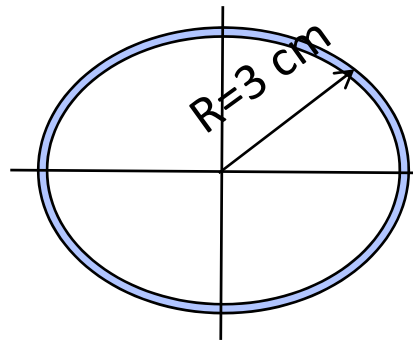
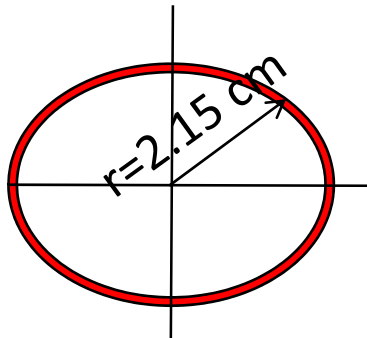
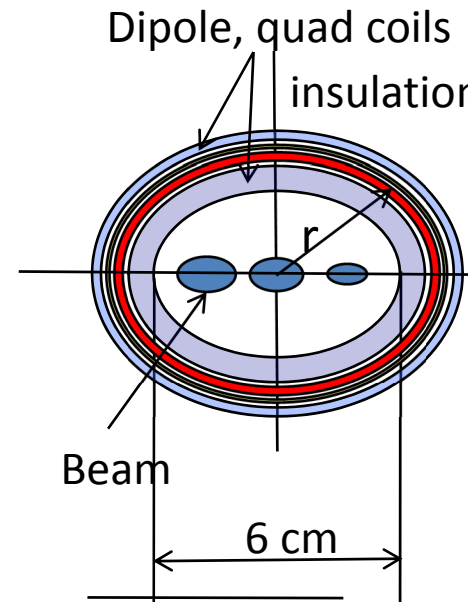

$$\text{Beam size : } \sigma_T = \sqrt{\sigma^2 + (D dp/p)^2}$$

$$\sigma_{\text{invis-max}} = \sqrt{\frac{N \epsilon_n \beta_{\text{invis}}}{6 \pi \gamma \beta}} = \sqrt{\frac{0.5 \cdot 0.5}{6 \cdot 0.452}} = 0.3 \text{ mm}$$

$$\sigma_\delta = 0.04 * 10^{-3} = 0.04 \text{ mm} \quad \text{If } D = 7 \text{ m} \rightarrow \sigma_\delta = 7 \text{ mm}$$

$$\epsilon_N = 0.5 \pi - 3 \pi \text{ mm mrad for } \epsilon_N = 3 \pi \mu\text{mrad } \sigma_{\text{invis-max}} = 0.74 \text{ mm}$$

$$6 \sigma = 2 \text{ mm} \quad (\text{for } \epsilon_N = 3 \pi \mu\text{mrad } 6 \sigma_T = 4.5 \text{ mm})$$

AML combined function magnet design

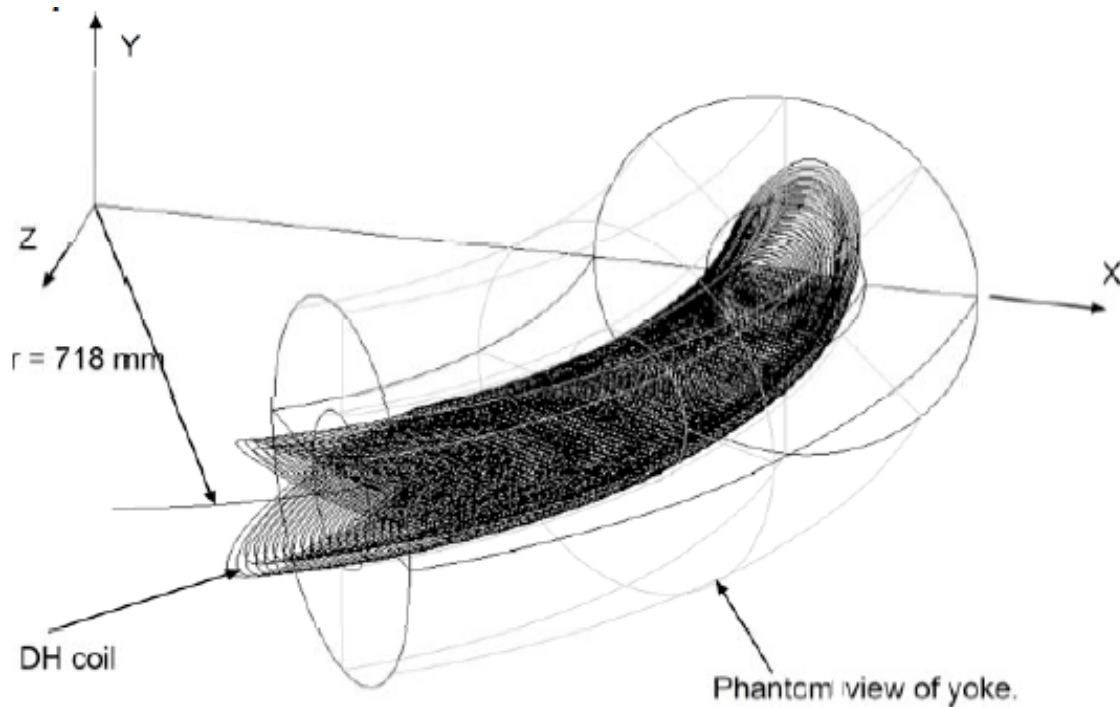

Figure 3. Diagram of a proposed 4-layer double-helix coil used in a 180° beam channel bend.

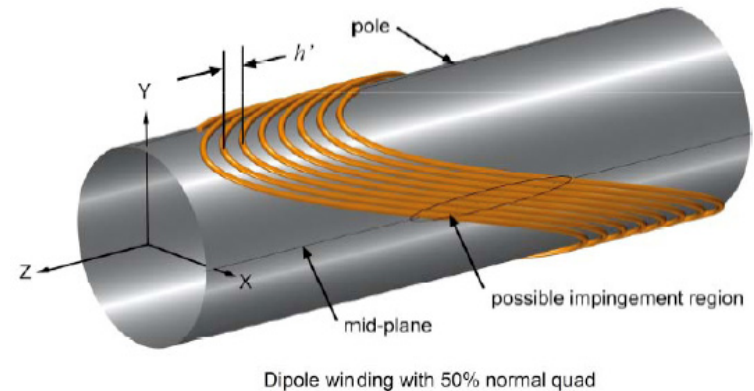
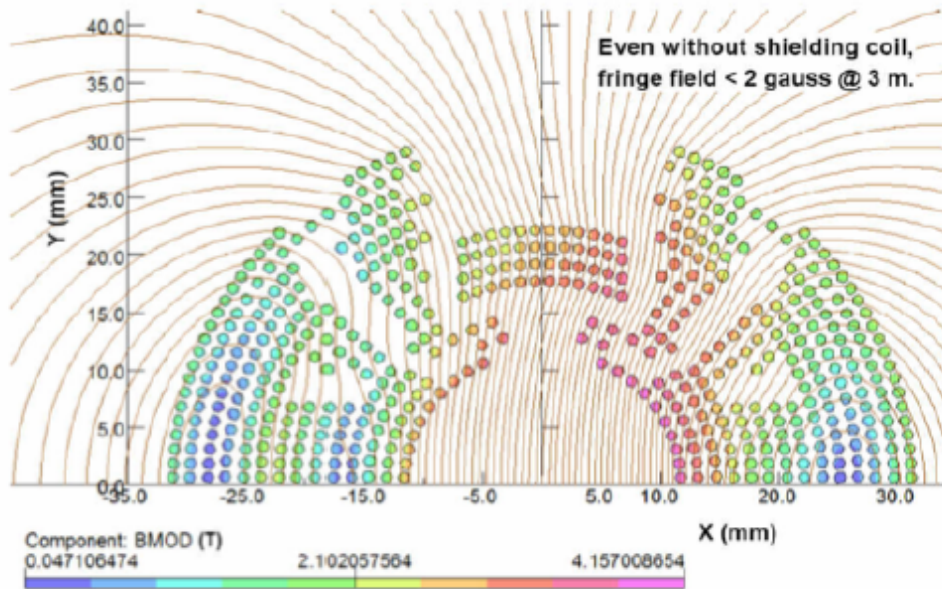

Figure 2. Dipole windings with 50% normal quad amplitude. The turn spacing, h' , has been increased due to the conductor impingement effect at the mid-plane.

BNL- combined function magnet design

Direct Wind Combined Function Gantry Magnet



Direct Wind Combined Function Gantry Magnet

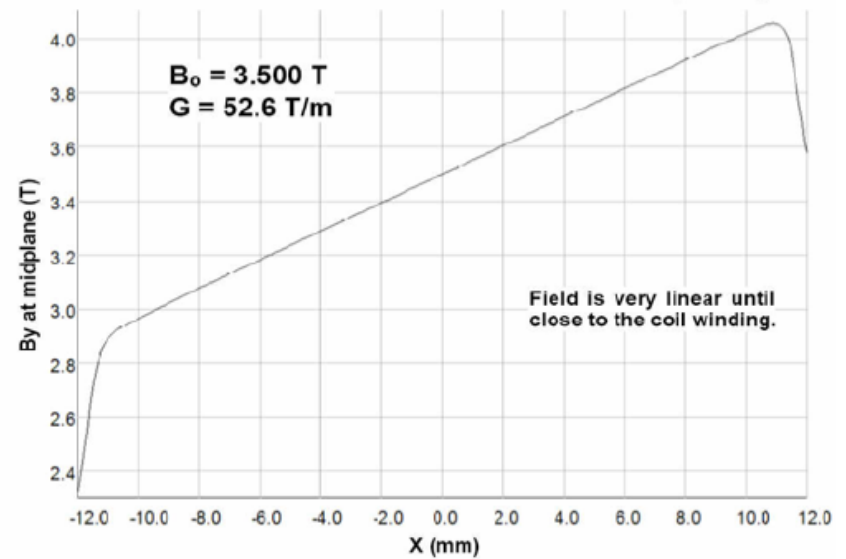

CRYO-COOLERS: reliable, maintenance free, easy to operate



4K Cryocooler Specification Chart

	Watts @ 50 Hz		Watts @ 60 Hz	
	1st Stage Capacity	2nd Stage Capacity	1st Stage Capacity	2nd Stage Capacity
RDK-101D	3.0 W @ 60 K	0.1 W @ 4.2 K	5.0 W @ 60 K	0.1 W @ 4.2 K
RDK-305D	15 W @ 40 K	0.4 W @ 4.2 K	20 W @ 40 K	0.4 W @ 4.2 K
RDK-205D	3.0 W @ 50 K	0.5 W @ 4.2 K	4.0 W @ 50 K	0.5 W @ 4.2 K
RDK-408D2	34 W @ 40 K	1.0 W @ 4.2 K	44 W @ 40 K	1.0 W @ 4.2 K
RDK-415D	35 W @ 50 K	1.5 W @ 4.2 K	45 W @ 50 K	1.5 W @ 4.2 K

SUMMARY:

1. NS-FFAG gantries provide transfer of carbon ions with $\Delta p/p = \pm 20\%$ (200-400 MeV – or - 100-200 MeV).
1. Weight is reduced for one or two orders of magnitude.
2. Size of NS-FFAG the carbon gantry is of PSI proton one.
3. Operation is simplified as the magnetic field is fixed.
4. Scanning system is with $SAD = \infty$.
5. Beam size is adjustable with the triplet magnets.
6. Triplet magnets do not need to be superconducting.