

PHOTONIC BANDGAP FIBER WAKEFIELD EXPERIMENT AT SLAC*

R. J. England, E. R. Colby, C. M. McGuinness, R. Noble, R. H. Siemann, J. E. Spencer, D. Walz,
SLAC National Accelerator Laboratory, Menlo Park, CA 94025, USA

R. Ischebeck, Paul Scherrer Institute, Switzerland

C. M. S. Sears, Max Planck Institute for Quantum Optics, Garching, Germany

T. Plettner, KLA Tencor, Milpitas, CA 95035, USA

Abstract

An experimental effort is currently underway at the SLAC National Accelerator Laboratory to focus a 50 pC, 60 MeV electron beam into the hollow core of a commercial photonic bandgap fiber. The wakefield radiation produced in the fiber will be spectrally analyzed using a spectrograph in order to detect the frequency signatures of fiber modes that could be used as accelerating modes in a laser-driven fiber-based accelerator scheme. We discuss the current status of the experiment, including efforts to successfully focus the electron beam through the fiber aperture and to collect the produced wakefield radiation.

INTRODUCTION

In the drive to achieve beam energies in the TeV range and beyond, it is critical to develop new technologies for particle acceleration which combine higher gradient (> 200 MV/m) acceleration with reduced cost. One possibility which has been proposed in recent years is the use of micron-scale dielectric structures driven by lasers operating in the optical to near infrared regime [1, 2, 3]. The use of a laser as the drive source for the accelerating field offers several benefits, including the high rep-rates (> 10 MHz) and strong electric fields (> 0.5 GV/m) which modern lasers can provide, combined with improved commercial availability and cost when compared with microwave sources. The use of dielectric structures circumvents the problem of power loss in metallic cavities at optical frequencies; it also allows for much larger accelerating gradients due to the higher breakdown thresholds (1-5 GV/m) of dielectric materials.

One promising candidate structure for a future laser-driven dielectric accelerator is the photonic bandgap (PBG) fiber [3]. We recently proposed an experiment to use commercially available hollow-core PBG fibers for proof-of-principle laser acceleration experiments at the E-163 facility at the SLAC National Accelerator Laboratory [4]. The NLCTA beamline and E-163 experimental hall are illustrated in Fig. 1. Several of the available fibers by Crystal Fibre Inc. (HC-633, HC-1060, HC-1550, and HC-800) have been found in simulations using the photonic crystal code BANDSOLVE to support speed-of-light traveling wave modes suitable for particle acceleration. The initial phase of the experiment is to propagate a 60 MeV electron

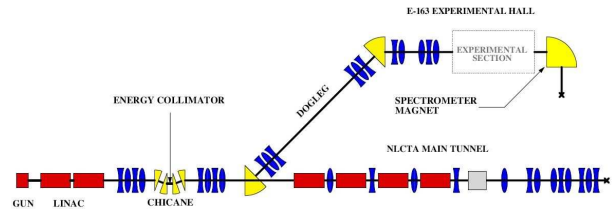

Figure 1: Schematic of the NLCTA and E-163 test beamline (not to scale).

beam through the hollow cores of these candidate fibers and then spectrally resolve the signatures of the accelerating modes from the resultant wakefield radiation emitted at the end of the fiber. The most promising of these fibers (the HC-1060) has a predicted maximum accelerating gradient of 30 MV/m at a mode frequency of 1080 nm. The gradient limit is set by the ratio of the peak field in the PBG lattice to the axial field ($DF = 166$) combined with the estimated damage threshold at this frequency ($E_{max} = 5$ GV/m). Optimized fiber geometries, such as that proposed by Lin, promise improvements over this limit by 2 orders of magnitude, via reduction of the peak-to-axial field ratio DF . The wavelengths of the accelerating modes differ from the design wavelengths of the fibers because they are TM_{01} -like modes, which have been constrained to have speed-of-light phase velocity, and are therefore not among the TE-like telecom modes.

EXPERIMENT OVERVIEW

The E-163 fiber experiment is a multi-phase effort, the ultimate goal of which is to develop custom-built fibers, optimized for efficient laser power coupling and high-gradient particle acceleration, into a working accelerator. The first two phases of this plan are illustrated in Fig. 2: a beam-driven wakefield experiment (a) using available commercial fibers and a follow-up net acceleration experiment (b) using a microbunched electron beam and a fiber driven by a laser that is end-coupled to the fiber core. The microbunching scheme, recently demonstrated [5], uses an IFEL interaction followed by a chicane compressor to produce sub-femtosecond microbunches spaced at the laser wavelength.

For the initial fiber wakefield experiments of Fig. 2(a), a triplet of permanent magnet quadrupoles (PMQs) will be used to focus a 50 pC beam of 60 MeV electrons generated by the NLCTA photoinjector gun and X-band accelerator

* Work supported by U.S. Department of Energy under Grants DE-AC02-76SF00515, DE-FG06-97ER41276

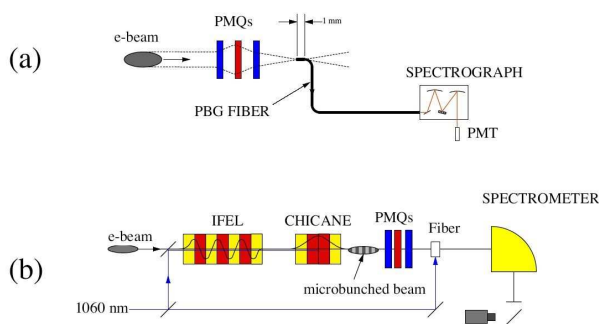

Figure 2: Experimental layouts (not to scale) for the (a) fiber wakefield experiment and (b) follow-up net acceleration experiment.

through the hollow cores of the four candidate PBG fibers. The fibers are held in an aluminum keeper which constrains them to a 1 mm straight section, followed by a 90 degree turn which bends them out of the beam path on a 3 mm radius. The keeper also incorporates two beam diagnostics: an yttrium aluminum garnet (YAG) profile monitor and a tantalum knife edge for measuring the spot size at the focus of the PMQs. The fibers and the diagnostics can be precisely moved into or out of the beam path by way of an in-vacuum stage assembly with 4-axes of control (x, y, tip, and tilt) and 50 nm spatial resolution.

When the fiber is excited incoherently by the Schottky noise of an unbunched beam, the energy deposited per unit length into a fiber mode with wavelength λ and characteristic impedance Z_c scales linearly with the number N of electrons according to $dU/dz = kNe^2$ where $k = c\beta_g Z_c / [4(1 - \beta_g)\lambda^2]$, is the loss factor of the mode and β_g is the group velocity normalized to speed of light [6]. For the accelerating mode of the HC-1060 fiber, $k = 1.4 \times 10^{18}$ J/C²m, which gives an expected yield of 3100 photons for a 50 pC beam (at 50% coupling efficiency) and interaction length $L = 1$ mm.

To reduce photon losses, the fiber lengths have been minimized and connectorized feedthroughs have been avoided. The primary losses expected are therefore due to F-number mismatch, grating efficiency (85%), and the reflectivity of the mirrors (88%) in the spectrograph (Newport model MS-260i), giving an expected throughput of approximately 38%. One can therefore expect about 1100 photons to reach the detector (a Hamamatsu R1767 photomultiplier tube). Due to the low photon count, care will have to be taken to reduce stray light and background from Cherenkov radiation trapped in the fiber cladding. Estimates presented previously [4] indicate that the total Cherenkov photon yield exceeds the signal by at least an order of magnitude. Taking advantage of the fact that higher-order modes have higher bend losses than the core modes, the fibers are wound around a 1-inch diameter post after exiting the vacuum chamber to shed off any Cherenkov light coupled into the fiber cladding.

Advanced Concepts

A14 - Advanced Concepts

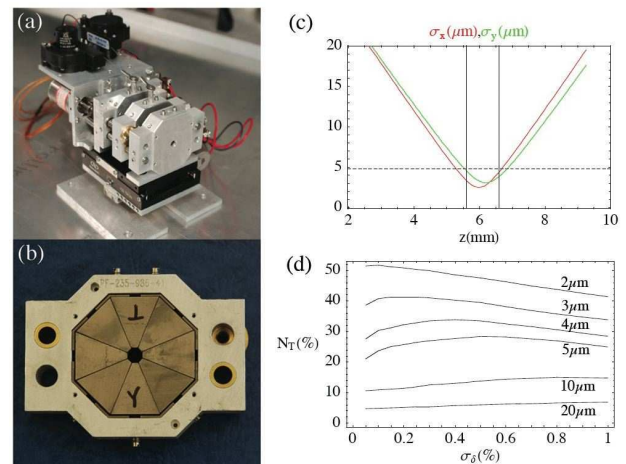

Figure 3: Images of (a) the assembled PMQ triplet and (b) a closeup of one magnet, with simulated plots of (c) the optimized focal waist and (d) fiber transmission (HC-1060 fiber) vs. energy spread for various emittances.

PERMANENT MAGNET QUADRUPOLES

The small apertures of the candidate fibers' central defects (1.7 to 10 μm diameter), requires high-gradient focusing magnets for successful beam-to-fiber coupling. A previously constructed hybrid iron and permanent magnet quadrupole triplet was found to not be suitable for this application due to insufficient field gradient. Consequently, a new triplet of Halbach-style [7] PMQs has recently been constructed and assembled, as shown in Fig. 3(a) and (b). Each PMQ is constructed from 8 trapezoidal wedges of neodymium iron boron (NdFeB) held in an octagonal titanium retainer ring surrounded by an aluminum keeper.

The PMQ spacings (and hence their net focal length) can be adjusted by way of threaded rods driven by remotely controlled vacuum motors. Position read-back is provided by a pair of linear string encoders. Additional actuators permit longitudinal (z) and lateral (x) translation of the whole assembly to permit adjustment of the focus location and removal from the beam path.

The field gradients from simulations using the magneto-statics code RADIA [8] are 500T/m for the 7mm magnet and 600T/m for the 15mm magnets. The focal waist of the beam for normalized transverse emittances of $\epsilon_{N,x,y} = 2 \mu\text{m}$ (simulated using the particle tracking code ELEGANT [9]) is shown in Fig. 3(c). The vertical lines mark the boundaries of the 1mm straight section of fiber, and the horizontal dashed line marks the radial aperture. The momentum spread of $\sigma_\delta = 0.24\%$ corresponds to recent measurements taken at full charge (50 pC). Fiber transmission vs. energy spread for the HC-1060 fiber is plotted in Fig. 3(d) for various normalized emittances (labeled on the curves in units of μm) indicating a maximum transmission of around 50%. These curves indicate that the transmission is relatively insensitive to chromatic effects, but is critically affected by the beam emittance. For this reason, recent efforts have fo-

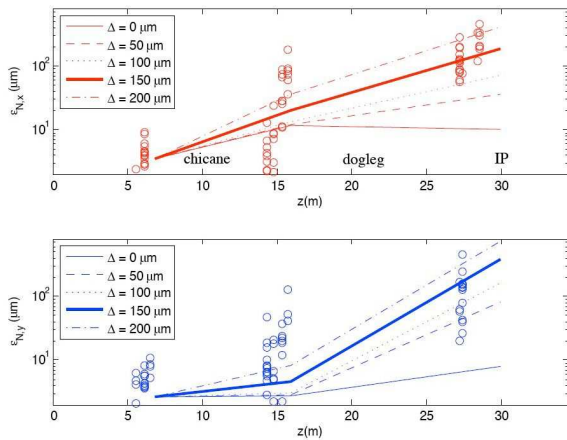

Figure 4: Compiled emittance data along the beamline superimposed with ELEGANT simulation values (connected by straight lines for clarity) for several values of the imposed RMS steering error Δ in the quadrupoles.

cused on reducing emittance growth in the E-163 beamline.

EMITTANCE STUDIES

In order to better understand the issues related to emittance preservation in the E-163 beamline, recent efforts have concentrated on developing new computational and hardware tools to aid in characterizing the beam dynamics. These include the development of Matlab-based software for automating the tasks of beam profile measurement, quad scans, and dispersion measurement, the installation of high-resolution gigabit ethernet cameras at critical locations, and careful calibration of the various profile monitors.

Emittance measurements obtained from quadrupole scans taken over the course of three months are shown in Fig. 4. The large variance in values indicates the potential for emittance growth following both the chicane and dogleg sections. This growth is largely due to geometrical aberrations from off-center steering and large spot sizes in these devices. ELEGANT simulation values at three locations (connected by lines for visualization purposes) are shown for five values of the RMS steering offset error Δ in the quadrupoles. The thick lines correspond to the typical day-to-day offset error ($\Delta \approx 150 \mu\text{m}$) indicated by the beam position monitors. By minimizing steering and carefully adjusting the upstream matching quadrupoles to control the transverse beam dimensions and cancel the horizontal and vertical dispersions in both the chicane and dogleg sections, final normalized emittances in the low tens of microns have been achieved prior to the beam-fiber interaction point, marked as "IP" in Fig. 4. However, this is still an order of magnitude higher than the emittances needed for optimal beam-to-fiber coupling, as indicated by Fig. 3(d).

The simulations indicate that single-digit micron emittances after the dogleg section are theoretically possible.

However, duplicating these results in the physical machine will require improvements in the stability and reproducibility of the magnetic lattice and the beam initial conditions. Efforts to accomplish these goals will include upgrades to the photoinjector laser transport system, direct monitoring of the field strengths of critical magnets, photoinjector studies to reduce the upstream emittance of the beam, and implementation of steering feedback to minimize offsets in the quadrupoles.

CONCLUSIONS

An experiment is underway at the E-163 test beamline at SLAC to use commercial photonic bandgap (PBG) fibers as laser-driven dielectric accelerating structures. At least one of the fibers under study (HC-1060) has been found in simulations to support accelerating modes. The first stage of experiments will attempt to measure the fiber modes directly by spectrally resolving the wakefield excitation produced by a 60 MeV electron beam focused through the hollow core of each fibers. To these ends, a purpose-built triplet of permanent magnet Halbach quadrupole magnets, designed to produce field gradients in excess of 500 T/m, has recently been constructed and assembled. In order to achieve the requisite transverse spot sizes ($<10 \mu\text{m}$) for successful transport of the electron beam through the small-aperture cores of the PBG fibers, efforts have been made to characterize and mitigate emittance growth in the large dispersive sections (chicane and dogleg) on the E-163 beamline. The smallest normalized emittances achieved are on the order of 20 to 40 μm . Additional reduction in emittance growth and improvement of system stability will be accomplished through upgrades and further refinement of the analysis tools recently implemented.

REFERENCES

- [1] Rosing, M., and Gai, W., *Phys. Rev. D*, **42**, 1829–1834 (1990).
- [2] Mizrahi, A., and Schachter, L., *Phys. Rev. E*, **70**, 016505 (2004).
- [3] Lin, X. E., *Phys. Rev. ST-AB*, **4**, 051301 (2001).
- [4] England, R. J., Sears, C. M. S., Colby, E. R., Cowan, B., Ischebeck, R., McGuinness, C. M., Noble, R., Siemann, R. H., Spencer, J., Walz, D., Byer, R., and Plettner, T., "Experiment to Detect Accelerating Modes in a Photonic Bandgap Fiber," in *Proceedings of the 2008 Advanced Accelerator Concepts Workshop*, 2008, IEEE, pp. 550–555.
- [5] Sears, C. M. S., and et al., *Phys. Rev. ST-AB*, **11**, 101301 (2008).
- [6] Siemann, R. H., *Phys. Rev. ST-AB*, **7**, 061303 (2004).
- [7] Halbach, K., *Nucl. Inst. Meth.*, **169**, 1–10 (1980).
- [8] Chubar, O., Elleaume, P., and Chavanne, J., *Journal of Synchrotron Radiation*, **5**, 481–484 (1998).
- [9] Borland, M., ELEGANT: A Flexible SDDS-Compliant Code for Accelerator Simulation, Tech. Rep. LS-287, Argonne National Laboratory Advanced Photon Source, Argonne, IL (2000).