

# AN ALTERNATIVE APPROACH FOR THE JLEIC ION ACCELERATOR COMPLEX\*

B. Mustapha<sup>†</sup>, P. Ostroumov<sup>‡</sup>, A. Plastun and Z. Conway, ANL, Argonne, IL, USA,  
V. Morozov, Y. Derbenev, F. Lin and Y. Zhang, JLab, Newport News, VA, USA

## Abstract

The current baseline design for the JLab EIC (JLEIC) ion accelerator complex is based on a 280 MeV pulsed superconducting linac, an 8-GeV booster and a 20-100 GeV ion collider ring. We are considering an alternative design approach to lower the risk of the project and reduce the footprint of the ion complex. The proposed approach also includes the possibility of staging. In order to reduce the footprint of the ion complex, we propose to use a more compact 130 MeV linac, a compact 3-GeV pre-booster, and to consolidate the electron storage ring (e-ring) as a large booster for the ions. Considering the current parameters of PEP-II magnets, to be used for the e-ring, protons could reach 12 GeV. With new magnets, proposed for an alternative low-emittance design of the e-ring, the energy could reach 15 GeV. In these options, room-temperature magnets are used in the pre-booster and e-ring. The ion collider ring could be staged, first with room-temperature magnets for proton energy up to 60 GeV then later upgraded with either 3 T super-ferric magnets up to 100 GeV or with 6 T fully superconducting magnets up to 200 GeV. A brief description of the proposed alternative ion complex and a preliminary parameter study of the e-ring as an ion booster are presented. More detailed studies are underway to investigate the feasibility and evaluate the different options.

## THE BASELINE DESIGN OF JLEIC

The layout of the current baseline design for the Jefferson Lab Electron-Ion Collider (JLEIC) [1] is shown in Fig. 1. The ion complex consists of a pulsed superconducting linac with 280 MeV proton energy, an 8-GeV booster ring and a 20-100 GeV collider ring. Both the booster and collider rings are based on 3 Tesla super-ferric magnets [2]. The electron complex consists of the existing CEBAF machine as a full-energy injector to a new storage ring at 3-10 GeV. The electron ring (e-ring) re-uses the magnets and RF system from the decommissioned PEP-II e+e- collider at SLAC.

\* This work was supported by the U.S. Department of Energy, Office of Nuclear Physics, under Contract No. DE-AC02-06CH11357 for ANL and by Jefferson Science Associates, LLC under U.S. DOE Contract No. DE-AC05-06OR23177

<sup>†</sup> Corresponding author: brahim@anl.gov

<sup>‡</sup> Now at MSU

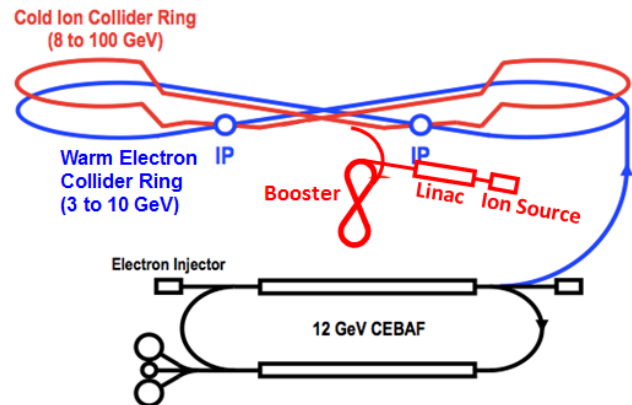

Figure 1: Layout of the current JLEIC baseline design.

## MOTIVATIONS FOR AN ALTERNATIVE APPROACH

The main driving factors for considering an alternative design approach for the JLEIC ion complex are:

- Lower the risk of the project by using the proven technology of room-temperature (RT) where possible, with the possibility of upgrade with super-ferric (SF) or superconducting magnets (SC).
- Reduce the footprint of the ion complex for potential cost savings by using more compact linac and pre-booster ring, and consolidate the electron storage ring as large booster for the ions.
- Consider the possibility of staging the ion collider ring, first with RT magnets up to 60 GeV, then later with SF magnets up to 100 GeV or SC magnets up to 200 GeV.

## THE PROPOSED ALTERNATIVE OPTION

The layout of the proposed alternative design is shown in Fig. 2. It consists of:

- A more compact 130 MeV linac [3].
- A more compact 3-GeV pre-booster using RT magnets [4]. At this energy, the figure-8 shape is not required, Siberian snakes with reasonable fields could be used for spin corrections.
- The e-ring as large ion booster, up to 12 GeV protons with PEP-II magnets or 15 GeV with new magnets.
- The ion collider ring with RT magnets could reach a proton energy of 60 GeV, or with 6 T SC magnets up to 200 GeV.

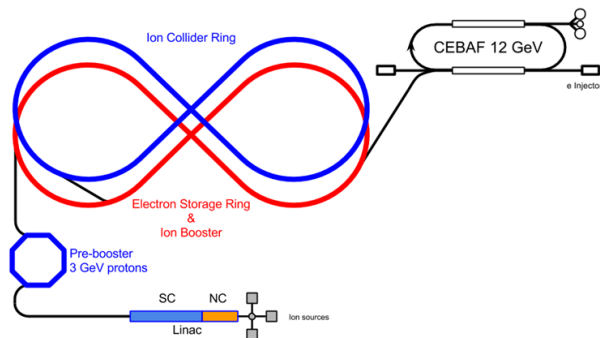

Figure 2: Layout of the proposed alternative design.

### A More Compact Injector Linac

The injector linac was re-designed to be more compact, taking advantage of the high-performance of QWR and HWR cavities demonstrated at Argonne [5, 6]. The linac energy was also reduced from ~ 280 MeV to ~ 130 MeV for protons [3]. The SRF nature of the linac allows more tuning flexibility and higher energy for the heavy ions than a warm linac. The output energy for lead ions is 44 MeV/u. Figure 3 presents the linac layout with total length of about 60 meters. More details about the room-temperature front-end design can be found in [7].

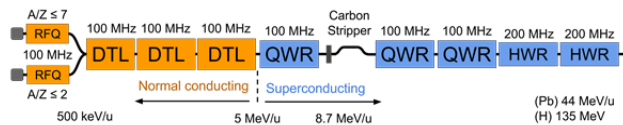

Figure 3: Layout of the compact multi-ion linac.

### A COMPACT PRE-BOOSTER RING

We propose to replace the 8-GeV booster with a more compact 3-GeV pre-booster ring. At this energy, the figure-8 is not required and the ring can be of race-track or higher order shape. Figure 4 shows a comparison between the original figure-8 design [8] and the proposed octagonal design. The circumference and the total number of magnets were reduced by a factor of two. More details about the design optimization of the pre-booster ring and the proposed octagonal design can be found in [4].

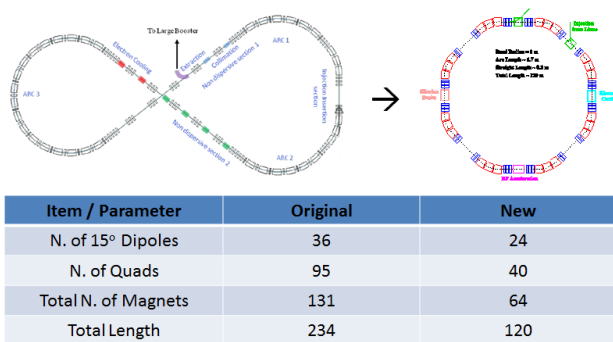

Figure 4: Comparison between the original figure-8 and the new octagonal designs for the 3-GeV pre-booster.

### The e-Ring as Large Ion Booster

At 3 GeV, the pre-booster ring is not suited for direct injection into the ion collider ring, therefore we propose to use the e-ring as an intermediate energy ion booster. A preliminary parameter study shows that it's possible and Table 1 summarizes the different options. The lattice is based on a FODO cell (two dipoles and two quadrupoles) with given length, and 90 deg phase advance per cell. The first option is the baseline design with PEP-II magnets. The second is a low-emittance design with new magnets being considered for the e-ring. The third design option with longer cells and high-gradient SF or SC quadrupoles, offers the possibility of even lower emittance to the theoretical minimum emittance (TME) for the electrons and higher energy for the ions. In this option, the horizontal phase advance per cell is ~ 270 deg.

Table 1: Options for the e-Ring as Large Ion Booster

Parameter	Baseline design	Low-emittance design	TME design with SF/SC quads
Cell length (m)	15.2	11.4	22.8
Transition $\gamma$	15	20	33
proton (GeV)	12	15	30
Pb (GeV/u)	4.8	6	12
Dipole (T)	0.36	0.5	1.1
Quad (T/m)	15	25	60
Limitation	Dipoles	Quads	-

It is important to note that in all of these options, all ions are extracted below the transition energy of the e-ring. Although, the protons could reach 30 GeV in the case of TME lattice with SF or SC quadrupoles, it will be extracted at ~ 15 GeV, first to avoid energy transition and second to allow lower-energy collisions of ~ 20 GeV in the collider ring. The advantage of this last option is the possibility of injecting all ions above the transition energy of the collider ring with  $\gamma_{tr} \sim 12.5$ . In the other two options, ions other than protons will have to cross the transition energy in the collider ring.

### Options for the Ion Collider Ring

Similarly to the e-ring as large ion booster, different options are being considered for the ion collider ring. Table 2 summarizes the parameters for these options, namely a fully RT option up to 60 GeV for protons, or with SF magnets up to 100 GeV or with fully SC magnets up to 200 GeV. The choice between these options will be decided by the physics and the budget limit of the project.

Table 2: Options for the Ion Collider Ring

Parameter	RT	SF	SC
	Magnets	Magnets	Magnets
Dipole (T)	1.6	3.0	6.0
proton (GeV)	60	100	200
Pb (GeV/u)	24	40	80

### POSSIBILITY OF STAGING

In addition to lowering the risk and reducing the footprint of the accelerator complex, the proposed alternative design approach offers the possibility of staging depending on the budget constraints of the project. One can imagine a first cost-effective phase based on RT magnets up to 60 GeV followed by a second phase with fully SC magnets up to 200 GeV.

### FUTURE WORK

In this paper, we have presented the concept for an alternative design approach for the JLEIC ion complex supported by a preliminary parameter study for using the e-ring as large ion booster and different options for the collider ring. A significant design and simulation effort is underway to prove the feasibility and evaluate the different options presented here. Among the issues being addressed, we list in particular:

- Study beam formation in the 3-GeV octagonal pre-booster including accumulation, acceleration and spin preservation.
- Find space in the e-ring to add RF sections for ion acceleration.
- Could the electron spin rotators be used to manipulate ion polarization? If not add dedicated spin correctors for the ions.
- Study the chromaticity and spin polarization in the TME option of the e-ring, as well as the effects of electron synchrotron radiation on the SF/SC magnets.

- Study the options of the ion collider ring with room-temperature and fully super-conducting magnets.
- Study the sequence of ion injection, acceleration and extraction from the e-ring before injecting electrons for storage and collision.
- Study the whole ion beam formation scheme with the goal of preserving both the high luminosity and polarization at the interaction points.

### REFERENCES

- [1] V. Morozov *et al.*, “Overview of Jefferson Lab EIC Design and R&D”, presented at NAPAC 2016, Chicago, IL, USA, October 2016, paper MOB2IO02, this conference.
- [2] J. Breitschopf *et al.*, “Superferric arc dipoles for the Ion Ring and Booster of JLEIC”, presented at NAPAC 2016, Chicago, IL, USA, October 2016, paper MOPOB54, this conference.
- [3] P. Ostroumov *et al.*, “Design and Beam Dynamics Studies of a Multi-ion Linac Injector for the JLEIC Ion Complex”, in *Proc. of HB2016*, Malmo, Sweden, July 2016, paper THPM5Y01, p. 559.
- [4] B. Mustapha *et al.*, “A More Compact Design for the JLEIC Ion Pre-Booster Ring”, presented at NAPAC 2016, Chicago, IL, USA, October 2016, paper TUPOB04, this conference.
- [5] M. Kelly *et al.*, “Commissioning of the 72 MHz Quarter-Wave Cavity Cryomodule at ATLAS”, in *Proc. of LINAC2014*, Geneva, Switzerland, Aug-Sept 2014, paper TUPP002, p. 440.
- [6] Z. Conway *et al.*, “Achieving High Peak Fields and Low Residual Resistance in Half-Wave Cavities”, in *Proc. of SRF2015*, Whistler, BC, Canada, Sept 2015, paper WEBA05, p. 973.
- [7] A. Plastun *et al.*, “Design of the Room-Temperature Front-End for a Multi-Ion Linac Injector”, presented at NAPAC 2016, Chicago, IL, USA, October 2016, paper MOB4CO04, this conference.
- [8] B. Erdelyi *et al.*, “An Accumulator/Pre-Booster for the Medium-Energy Electron Ion Collider at JLab”, in *Proc. of PAC2011*, New York, NY, USA, Mar-April 2011, paper WEP206, p. 1873.