

DEVELOPMENT OF SUPERCONDUCTING RADIO-FREQUENCY DEFLECTING MODE CAVITIES AND ASSOCIATED WAVEGUIDE DAMPERS FOR THE APS UPGRADE SHORT PULSE X-RAY PROJECT*

J. Holzbauer[†], A. Nassiri, G. Waldschmidt, G. Wu
 Argonne National Laboratory, Argonne, IL 60439, U.S.A.

Abstract

The Advanced Photon Source Upgrade (APS-U) is a Department of Energy (DoE) funded project to increase the available x-ray beam brightness and add capability to enhance time-resolved experiments on few-ps-scale at APS. A centerpiece of the upgrade is the generation of short pulse x-rays (SPXs) for pump-probe time-resolved capability using SRF deflecting cavities [1]. The SPX project is designed to produce 1-2ps x-ray pulses for some users compared to the standard 100ps pulses currently produced. SPX calls for using superconducting rf (SRF) deflecting cavities to give the electrons a correlation between longitudinal position in the bunch and vertical momentum [2]. The light produced by this bunch can be passed through a slit to produce a pulse of light much shorter than the bunch length at reduced flux. The ongoing work of designing these cavities and associated technologies will be presented. This includes the design and prototyping of higher- (HOM) and lower-order mode (LOM) couplers and dampers as well as the fundamental power coupler (FPC). This work will be given in the context of SPX0, a demonstration cryomodule with two deflecting cavities to be installed in APS in early 2014.

INTRODUCTION

The SPX project calls for the use of an RF deflecting-mode cavity to chirp electron bunches, giving the electrons a correlation between their longitudinal position in the bunch and their vertical momentum. Synchrotron light produced from this bunch can then be passed through a physical slit to create a shorter light pulse at the proportional sacrifice of total flux. This scheme was first proposed by Zholents [1]; the scheme can be seen in Figure 1.

A significant amount of design work has gone into the RF cavities required for this project, details of which can be found in [2, 3, 4, 5, 6, 7]. This cavity application has many specific challenges including the need to heavily damp all non-operational modes to preserve beam quality for other APS users.

CAVITY DESIGN

The current design is a squashed elliptical dipole-mode cavity with a Y-shaped end group and an on-cell damping

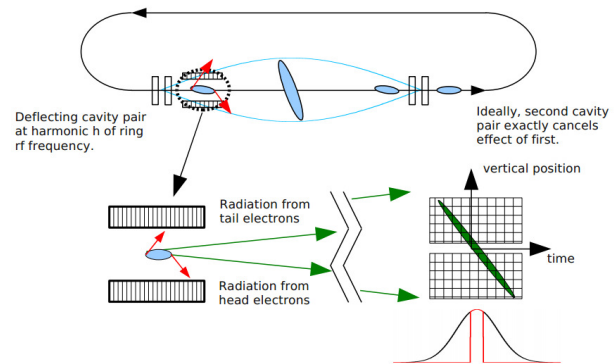

Figure 1: Schematic of Zholent's short pulse x-ray generation scheme. Image credit to [3].

port which can all be seen in Figure 2. Two of the waveguides from the Y end group will be used for damping of higher-order modes (HOMs) while the third will be primarily used as the forward power coupler. The on-cell damper is used primarily to damp the fundamental mode, called the lower-order mode (LOM). A list of the cavity parameters can be seen in Table 1.

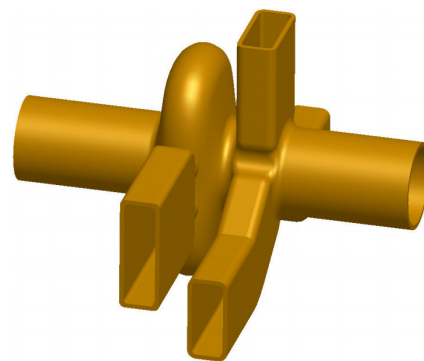

Figure 2: Schematic of a deflecting mode cavity for SPX. The LOM waveguide can be seen on-cell with the Y-end group (HOM dampers and FPC) to the right. Image credit to [3].

At this point, it is expected to use a BCP etching during cavity processing. Given the cavity parameters and this processing technique, 120 mT is the maximum expected reliable peak magnetic field. Given this and the requirement that each deflecting section have a total of 2 MV of

* Work supported by the U.S. Department of Energy, Office of Science, under Contract No. DE-AC02-06CH11357

[†] jholzbauer@aps.anl.gov

Table 1: Electromagnetic figures of merit

Parameter	Value
Frequency	2815 MHz
Q_0	10^9
Deflecting Voltage (V_t)	0.5 MV
Peak Surface Electric Field	41 MV/m
Peak Surface Magnetic Field	100 mT
Stored Energy	0.38 J
$P_{loss} Q_0 = 10^9$	7 W
$(R/Q)'$	18.6 Ω
Operational Temperature	2K

deflecting voltage to achieve 2-ps x-ray pulses [3], each cavity will be run at 0.5 MV deflecting voltage or 100 mT. In order to increase the operational margin, the possibility of electropolishing these cavities is being investigated.

HIGHER-ORDER MODE DAMPING

Because of the tight beam requirements, strong damping of non-operating modes was a focus of the overall cavity design. The squashed elliptical cavity geometry is meant to break the degeneracy of the dipole modes, increasing the frequency of the undesired dipole polarization as was done at KEK in the design of a similar deflecting mode cavity [8]. Significant work has been put into modeling of the cavities' broadband impedances [4], as well as the design of the HOM waveguides and dampers [7]. While the HOM waveguide design has been investigated in concept [9], their detailed design and packaging had not been considered until recently.

HOM Transitional Waveguide

Design of the SPX prototype cryomodule (SPX0) is well underway at JLab. Because of the broadband HOM damping requirements, it was decided to not use a window for the HOM dampers. This meant that all components of the HOM dampers would have to be assembled on the cold mass and had to fit inside the space frame for assembly. This is further complicated by the attachment of the tuner to the cavity very near to one of the HOM waveguide ports, making the HOM transitional waveguide (the waveguide running from the cavity to the damper itself) a very complex shape. This shape can be seen in Figures 3 and 4.

Despite these logistical requirements, the broadband transmission of this waveguide must not be compromised. The sizing of the HOM waveguide leading out of the cavity was chosen to have its cutoff frequency between the operational frequency (2.815 GHz) and the first higher-order mode (estimated at 2.94 GHz). The waveguide must connect this custom sized waveguide to the HOM dampers which are based on WG340 waveguide. The placement and geometry of this taper was carefully considered to both give adequate attenuation of the operational mode and decent broadband transmission of HOM power.

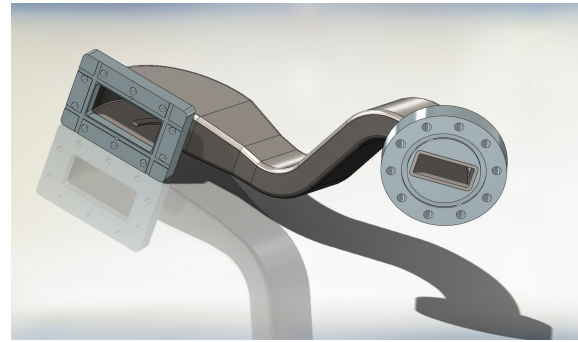

Figure 3: HOM Transitional Waveguide. Flange on the left connects to the cavity while the flange on the right connects to the damper assembly.

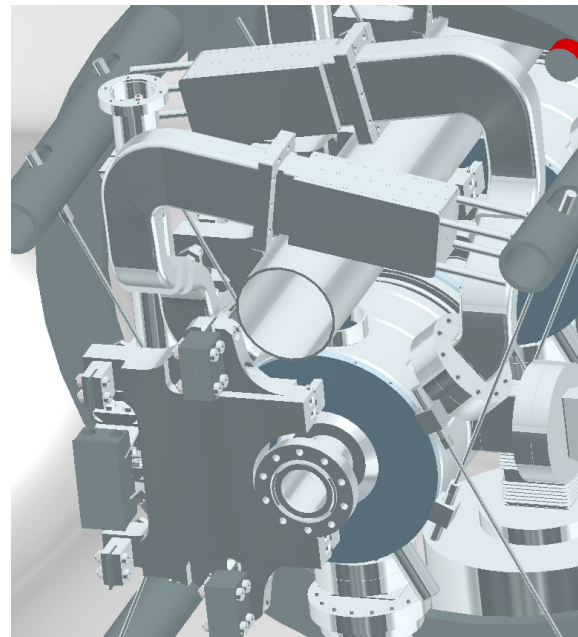

Figure 4: Section view of the SPX0 cryomodule space-frame mock-up. Cavity in helium vessel can be seen at the bottom of the image with tuner attached on the right side of the vessel. The HOM transitional waveguides and dampers can be seen crossing at the top of the image.

Given the space available, it was not possible to make the taper gradual enough to provide adequate broadband transmission because the first HOM (2.94 GHz) was still relatively close to cutoff. A ridge was added to this taper to improve transmission through the transition. The ridge was run through the taper on the wide wall and extended both toward the cavity into the S-Bend section and away from the cavity into the final, large radius bend. While this ridge improved transmission at 2.94 GHz, it also reduced transmission at some higher frequencies (3.0 GHz and 3.2 GHz) due to reflections off of the beginning of the ridge. The length of these ridge extensions was optimized to give the best broadband performance, the results of which can be seen in Figure 5. The length of the ridge extension into

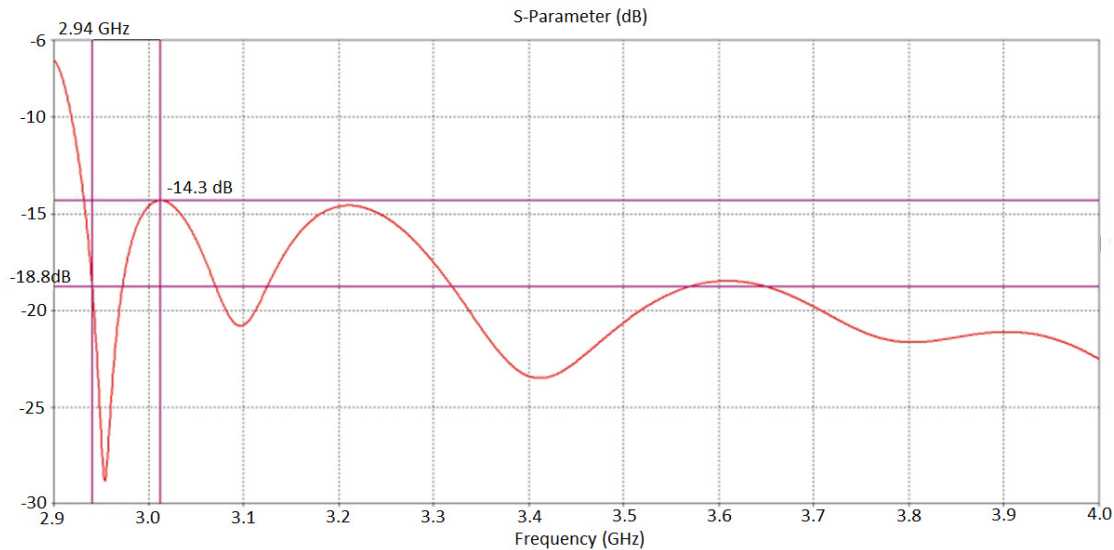

Figure 5: S11 parameter for the HOM Transitional Waveguide with optimized ridge. Reflection at the first HOM (2.94 GHz) is better than -18dB while the additional reflection cause by the ridge at 3.0 and 3.2 GHz is kept better than -14dB.

the S-Bend had the largest effect on performance. Longer ridges improved transmission at the first HOM frequency (2.94 GHz) but reduced performance at the higher frequencies. Without a ridge, S11 at 2.94 GHz was roughly -7dB, an unacceptably high reflection. Unfortunately, any reasonable ridge created the reflection at the higher frequencies which cannot be completely suppressed.

It is desired to keep the evanescent power from the operational mode reaching the HOM damper to below 10 W at full field to reduce total load on the damper. Simulations indicate that this traveling wave power should be 4.5 W, an acceptable number.

Waveguide Fabrication

When fabricated, the waveguide must be both mechanically robust and an adequate thermal barrier to keep the 2K heat load low. The HOM damper is water-cooled at room temperature outside the thermal shield and separated from the HOM transitional waveguide by a bellows, providing thermal resistance. The damper-end flange of this waveguide is expected to be strapped to the 80K cooling circuit. With a 1/8" wall of stainless steel and 10 microns of copper plating to improve RF performance, it is expected that this waveguide will contribute about 1.4 W (dynamic) to the 2 K heat load. Most of this comes from the evanescent fields in the beginning of the waveguide. Several fabrication methods are being considered for this complex geometry including fabrication from stainless steel sheet in parts, forming, and solid casting.

CONCLUSIONS

A credible design has been advanced for the HOM transitional waveguide. Prototyping is expected to begin in the coming months to validate the design and chosen fabrication process. SPX0 will provide an excellent test bed

for this design and its interface with the cavity and HOM dampers. Results from this testing will be used to improved this design if necessary for the final SPX cryomodules.

REFERENCES

- [1] A. Zholents et al., NIM A 425, 385 (1999).
- [2] A. Nassiri et al., "Status of the Short-Pulse X-Ray Project at the Advanced Photon Source, IPAC 2012, New Orleans, LA, May 2012.
- [3] Advanced Photon Source Upgrade Project - Conceptual Design Report, May 2011, <http://www.aps.anl.gov/Upgrade/Documents/CDR/>.
- [4] H. Wang et. al., "Design, Prototype and Measurement of a Single-Cell Deflecting Cavity for the Advanced Photon Source", presented at the 2009 Particle Accelerator Conference, Vancouver, BC, Canada, May 2009, WE5PFP059.
- [5] H. Wang et. al., "Crab Cavity and Cryomodule Prototype Development for the Advanced Photon Source", presented at the 2011 Particle Accelerator Conference, New York, NY, USA, March 2011, WEOCS7.
- [6] G. Waldschmidt et. al., "Status of RF Deflecting Cavity Design for the Generation of Short X-Ray Pulses in the Advanced Photon Source Storage Ring", presented at the European Particle Accelerator Conference, Edinburgh, Scotland, June 2006, THPLS076.
- [7] G. Waldschmidt et. al., "Superconducting Cavity Design for Short-Pulse X-Rays at the Advanced Photon Source", presented at the 2011 Particle Accelerator Conference, New York, NY, USA, March 2011, THP212.
- [8] K. Hosoyama et. al., "Crab Cavity Development", presented at the 2005 Superconducting RF Workshop, Ithaca, NY, USA, June 2005, ThA09.
- [9] L. Xiao et. al., "Higher Order Modes Damping Analysis for the SPX Deflecting Cavity Cryomodule", Proceedings of IPAC2012, New Orleans, Louisiana, USA, pp 2414 - 2416.