

# ILC MARX MODULATOR DEVELOPMENT PROGRAM STATUS\*

C. Burkhart#, T. Beukers, R. Larsen, K. Macken, M. Nguyen, J. Olsen, T. Tang,  
 SLAC, Menlo Park, CA 94025 USA, U.S.A.

## Abstract

Development of a first generation prototype (P1) Marx-topology klystron modulator for the International Linear Collider is nearing completion at the Stanford Linear Accelerator Center. It is envisioned as a smaller, lower cost, and higher reliability alternative to the present, bouncer-topology, “Baseline Conceptual Design.” The Marx presents several advantages over conventional klystron modulator designs. It is physically smaller; there is no pulse transformer (quite massive at ILC parameters) and the energy storage capacitor bank is quite small, owing to the active droop compensation. It is oil-free; voltage hold-off is achieved using air insulation. It is air cooled; the secondary air-water heat exchanger is physically isolated from the electronic components. The P1-Marx employs all solid state elements; IGBTs and diodes, to control the charge, discharge and isolation of the cells. A general overview of the modulator design and the program status are presented.

## INTRODUCTION

The International Linear Collider (ILC) will require 576 RF stations. Each 10 MW L-band klystron will require a modulator capable of; 120 kV, 140 A, 1.6 ms (27 kJ) at 5 Hz repetition rate. The existing Baseline Conceptual Design (BCD) is a transformer-based topology. The large size, weight, and cost of this transformer, owing to the long pulse length, have motivated research into alternative topologies that do not employ power magnetics.

The P1-Marx [1] modulator uses solid-state switches and isolation elements to connect capacitors in parallel while charging but in series during discharge to generate high voltage output without the use of a transformer.

## DESIGN OVERVIEW

The topology is illustrated in Fig. 1. A diode string provides a path for charging the 50  $\mu$ F capacitor of each of the 16 Marx cells to 11 kV and isolation between the cells during erection. Likewise, a second diode string provides a path for auxiliary power to each cell. A charge switch in each cell provides a common return path for both power sources.

Closure of a fire switch will produce a -11 kV output pulse from the cell; closure of additional switches will increase the output by -11 kV for each cell that is fired. The by-pass diode provides a conduction path to the load through the cells that have not been fired. The series inductor limits  $di/dt$  of the output current.

\*Work supported by the U.S. Department of Energy under contract DE-AC02-76SF00515

#burkhart@slac.stanford.edu

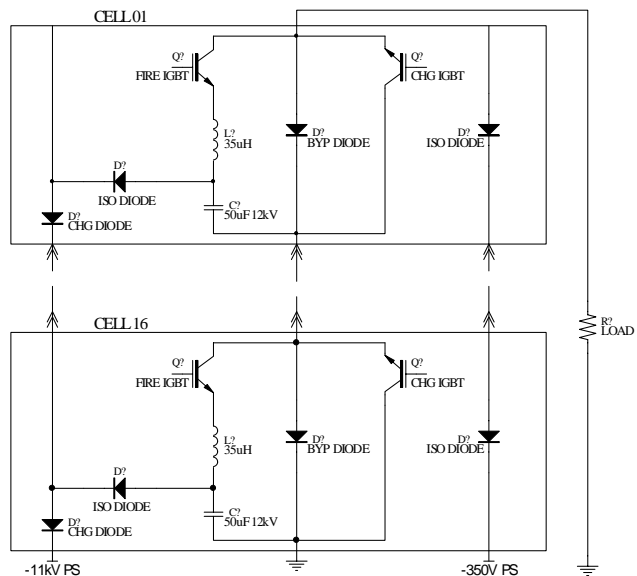

Figure 1: Simplified schematic diagram of the SLAC Marx.

Eleven cells are triggered to produce the required output voltage. As the energy storage capacitors discharge, the output voltage drops. Once it has decreased by 11 kV, in  $\sim 0.35$  ms, an additional cell is triggered to bring the output back to 120 kV. This proceeds sequentially through the remaining five cells to provide coarse,  $\pm 5\%$ , pulse flattening.

The output will be further regulated to  $\pm 0.5\%$  by a second Marx, the vernier regulator, in series with the main Marx. The topology of the vernier is similar to the main Marx, however each of the 16 cells is charged to 1.2 kV. These are fired sequentially to generate a stair-step waveform, which is added to the main Marx to maintain an approximately constant output voltage.

## Marx Structure

Fig. 2 is a photo of the P1-Marx modulator. A steel structure supports the modulator components and the control system (not visible, outside the enclosure in the front of the support structure). A hollow, cantilevered beam supports the individual Marx cells, forms a duct to direct the forced air coolant, and houses the control system fiber optic cables. It also supports a PCB backplane that provides the electrical interconnections between cells. When a cell is installed, it hangs from the beam, plugs into connectors on the backplane, and aligns the fiber optic lenses with those in the beam to transmit and receive optical control and diagnostic information.



Figure 2: Photo of the P1- Marx.

A grounding bar is lowered from supports above the modulator to ground out all cells for personnel protection during servicing. A high voltage divider is used to monitor the modulator output.

The design is intended to simplify maintenance. A cell is removed by lifting it off the backplane and a replacement cell is then set in place; there is no wiring to remove or install. Ambient air provides high voltage insulation. The polycarbonate panels in the enclosure door allow visual observation during developmental testing, while the internal mesh provides a bonded electrostatic enclosure. The 0.38 m spacing between the cell structure and enclosure walls provides sufficient insulation for the Marx voltage.

### Marx Cell Design

The Marx is a fundamentally modular topology, with inherent cost and maintenance advantages. The P1-Marx design fully exploits this trait. A Marx cell, shown in Fig. 3, consists of a PCB motherboard on which connectorized, modular components are mounted. The motherboard is supported by a backing frame that also supports the equipotential ring that surrounds the cell. The energy storage capacitor, capacitor discharge relay and resistor, and series inductor are permanently mounted on the motherboard; all other major components are modular.

The charge and fire switches are each an array of IGBTs, five modules connected in series. Each module uses three parallel IGBTs that are controlled by a common driver. During transient conditions, the voltage distribution between the series switches will be non-uniform. To protect the IGBTs from damage, over-voltage protection is incorporated into each switch module. The isolation boards translate auxiliary power and control signals from the reference potential to the emitter potential of each switch module. The control board, auxiliary power, and equipotential ring are referenced to the cell output potential.

The diodes; charge, charge isolation, by-pass, and auxiliary (on the same PCB as the by-pass) are each an array of eighteen series 1200 V ultra-fast soft-recovery

devices with a parallel MOV to assure uniform voltage distribution.

A CPLD on the control board sequences the firing of the charge and fire switches; the charge switch is gated off 10  $\mu$ s before the fire switch is gated on and then back on 10  $\mu$ s after the fire switch is gated off. The delays eliminate the shoot-through condition that would occur if both switches were on simultaneously. Both switches are monitored for an over current condition, which if detected remove the gate pulse from the switch.

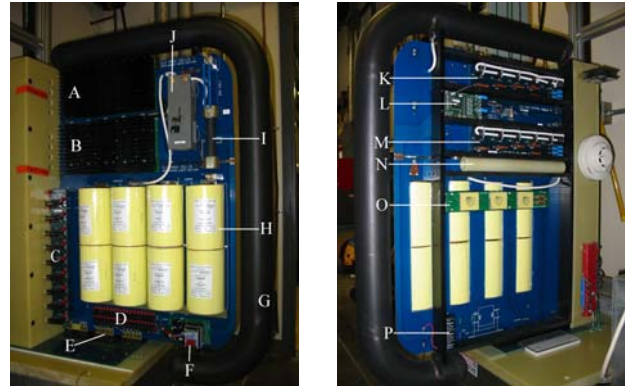

Figure 3: Photo of Marx cell, front (left) and rear (right), noting major elements. A: Charge IGBT module, B: Fire IGBT module, C: Charge diode, D: By-pass diode, E: Backplane connector group, F: Auxiliary power dc-dc converters, G: Equipotential ring, H: Energy storage capacitor, I: Discharge resistor, J: Discharge relay, K: Isolation board for charge switch, L: Control board, M: Isolation board for fire switch, N: Series inductor, O: Charge isolation diode, P: Auxiliary power storage capacitor

### Control System

The Marx employs a FPGA-based control system. A diagnostic module, with a jumper configurable address, is attached to the control card in each cell. Communication to the system ground station is over 60 Mb/s fiber optic data lines using point-to-point serial protocol. In the ground station, a FPGA communicates with a ColdFire processor, which provides the system's RTEMS-based EPICS IOC. The EPICS database contains the timing information, entered by the operator, and status and diagnostic information communicated from the Marx cells.

The diagnostic module passes timing information to the control board CPLD to coordinate the timing of the Marx cells. The diagnostic module also has four analog input channels to monitor voltages and currents on the Marx cell. The channels are monitored at 20 kS/s with a resolution of 16 bits. A fast transient recorder can also be triggered to capture each of the channels at 30 MS/s with an 8-bit resolution into a 2 kS buffer.

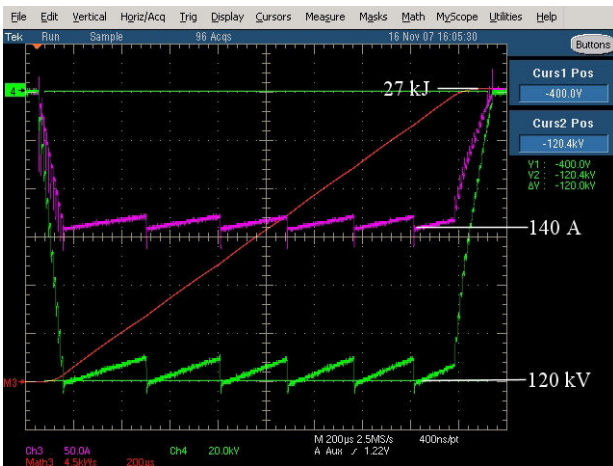

Figure 4: Marx output with coarse flattening, Ch3 is load current, Ch4 is load voltage, and Math3 is load energy.



Figure 5: Arc-down test of Marx during full voltage operation, Ch1 is load current and Ch4 is load voltage.

### TEST RESULTS

Individual modules are extensively tested for quality control purposes. Qualified modules are assembled into Marx cells, which are individually tested to 12 kV and 150 A. Cells are tested under normal operating conditions and short-circuit conditions. The over-current protection circuitry gates off the fire switches if the cell current exceeds 180 A. The turn-off delay is  $\sim 1.4 \mu\text{s}$ , which limits the peak cell current to  $\sim 600 \text{ A}$ .

Once cells have been qualified, they are assembled as a Marx. The vernier regulator is still under development, so the modulator is run with only coarse pulse flattening at present. Infrastructure issues currently prevent operation at full power, the modulator is run at either 1.6 ms pulse width and reduced PRF or at 5 Hz and reduced pulse width. The former is illustrated in Fig. 4. The turn on, and off, of the cells is staggered to reduce the peak current into the long cable that connects the modulator to the load in the test configuration. In the ILC implementation the cable would be eliminated, as could be the triggering delays, shortening the rise and fall times.

Arc-down tests were performed to simulate modulator behavior during a klystron arc. A spark-gap switch was installed in parallel with the test load. The switch was self-triggered, approximating the random nature of a klystron arc. Typical data for a 16-cell test is presented in Fig. 5 and 6. This event occurred  $\sim 15 \mu\text{s}$  after the third delay cell was triggered. The voltage rapidly collapses and the current rises. The maximum  $dI/dt$  is inductively limited,  $\sim 0.5 \text{ mH}$  internal inductance in the modulator and  $\sim 0.3 \text{ mH}$  at the load to protect the klystron from the energy stored in the cable from the modulator. The peak fault current,  $\sim 0.5 \text{ kA}$  is consistent with the test results for individual cells. The energy deposited into a klystron from such an event would be limited to a safe level,  $\sim 10 \text{ J}$ . At present, the cells individually detect and react to the over-current condition. Hence, delay cells 4 and 5 subsequently turn on, detect the fault, and turn off. System over-current detection will be added to the controls to provide a back-up and prevent these additional

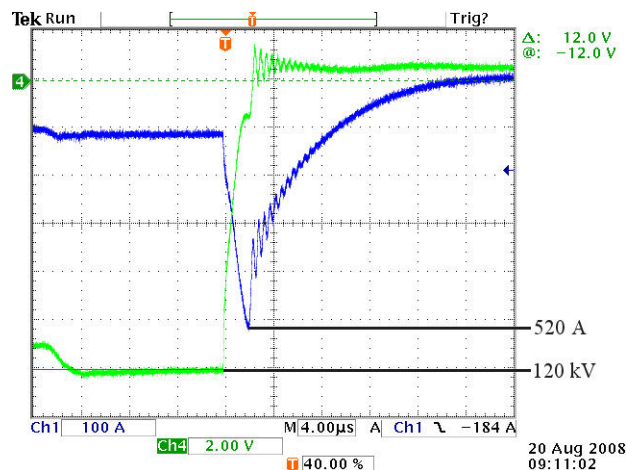

Figure 6: Detail of full voltage arc-down test, Ch1 is load current and Ch4 is load voltage.

pulses. Detailed examination of the voltage waveforms indicates good voltage sharing between cells under this transient condition.

The P1-Marx developmental testing is nearing completion. During the next quarter, it will be installed in a new L-band test facility at SLAC. The test facility will provide a platform for extensive life testing of the modulator and the new Toshiba 10 MW L-band klystron during FY09.

### ACKNOWLEDGMENT

The authors wish to acknowledge the significant contributions of D. Anderson, C. Brooksby (LLNL), R. Cassel, E. Cook (LLNL), G. Leyh, D. Moreno, P. Shen, and A. Vicerl to the SLAC Marx development program.

### REFERENCES

- [1] G.E. Leyh, "Development and Testing of the ILC Marx Modulator," Proc. of PAC07, Albuquerque, NM, pp. 849-851, 2007.