

PRELIMINARY DESIGN OF THE SLOW CHOPPER FOR THE SPIRAL 2 PROJECT

A. Caruso, A. Longhitano, D. Rifuggiato, G. Gallo, T. Sparta, E. Zappalà INFN/LNS, Catania, Italy
M. Di Giacomo, CEA/GANIL, Caen, France

Abstract

The Spiral 2 LEBT line uses a single chopper situated in the line section common to protons, deuterons and $A/Q=3$ ions. The paper describes the design and the test of the power circuits, based on standard components and working up to 10 kV, at a 1 kHz repetition rate.

THE LOW ENERGY LINE

The low energy (LEBT) line of the Spiral 2 driver is designed to transport CW, high intensity, beams of protons (5mA), deuterons (5mA) and ions (1mA) with $m/q=3$ to the radiofrequency quadrupole (RFQ). The RFQ input energy is 20 keV/A and source voltages of 20, 40 and 60 kV are used for the 3 kind of particles. As shown in Figure 1, the chopper is located at the beginning of the common section just before the beam stop.

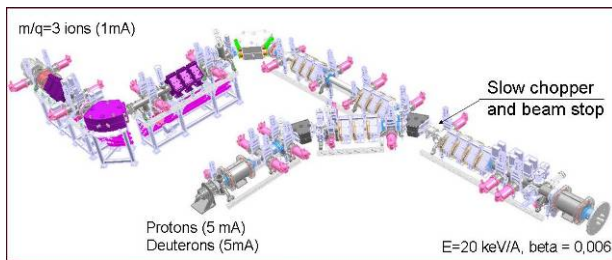

Figure 1: The injector low energy lines and the slow chopper position.

The chopper will be used to progressively increase the beam power during accelerator tuning, to rapidly remove the beam in case of failure detection, to avoid hitting the wheel spokes of rotating targets similar to the one shown in Figure 2 (FULIS or S3 experiences).



Figure 2: FULIS rotating target wheel (courtesy of C. Stodel).

CHOPPER REQUIREMENTS

Accelerator tuning is performed at quite low frequency. Due to the high beam power: 200 kW, a very large range of duty cycles will be used, starting from very low fractions (10^{-4}). The rotating target asks for

pulse repetition rates around 1 kHz. In both cases rapid transition times are required to avoid fractions of beam neither accelerated nor deviated to be lost through the linac.

The chopper voltage depends on the ion source voltage on the distance and length of the plates and on the beam stop location. Due to the LEBT line architecture and to the current intensity, the beam transversal section at the chopper location is quite large and relevant voltages have to be applied to the electrodes to compensate their distance.

In our case, the beam section has a diameter of 76 mm, the electrode hard-edge length considered in the beam dynamics simulations is of 160 mm, deflection at the end of the plates is of 10 mm, and a total deviating voltage of 17 kV has to be applied. Transient times for the pulse have to be shorter than 100 ns, and an amplitude stability of few percents is required.

High reliability and easy maintenance are also strong requirements of the devise.

ELECTRODE GEOMETRY

The preliminary geometry shown in Figure 3 was designed to have a flat transversal field and to produce field maps for beam dynamic simulations. Two cases were simulated: a) one plate positively biased and one grounded and b) both plates biased with opposite voltages but no differences were observed.

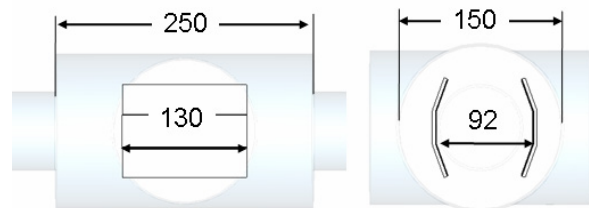

Figure 3: The simulated geometry, plate bending angle is 20° .

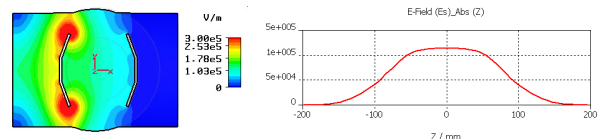

Figure 4: Electric field on the transversal plane and on the beam axis.

The first case, with positive voltage, was chosen, because it would let easier water cooling of the ground electrode if some beam was eventually lost. The deflection plane is horizontal because the beam section is

smaller on this plane than on the vertical one. To obtain the deviating field, a pulse of 9.2 kV has to be applied to the electrode, whose capacitance is around 15 pF. The pulse duty cycle defines the attenuation on the beam.

SLOW CHOPPER DEVELOPMENT

The development of the Spiral 2 device is foreseen in two years. In this first year, the power circuit, the feed-through and the assembling concept has been studied and tested on a prototype.

The design approach was strongly addressed towards reliability and decrease of the maintenance time, both being very important issues in high power accelerators. For the electrical parts, we have searched for standard commercial devices that are easy to check and to replace in case of failure. For the mechanical assembling concept, we chose to have no isolators between the plates, as Alumina could break and spread activated fragments. Each electrode is then supported by its flange.

Electrical Design

The principle scheme of the chopper is represented in Figure 5.

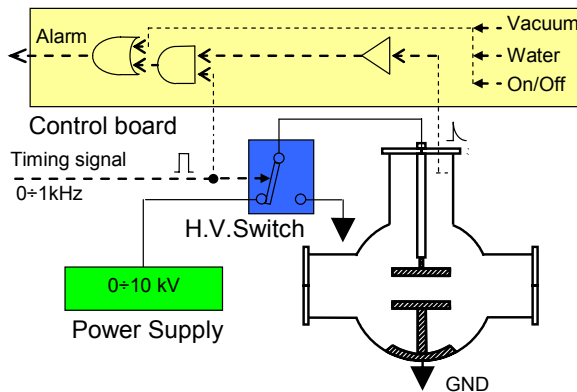

Figure 5: Principle scheme of the chopper.

The high voltage switch alternatively connects the electrode to ground or to the high voltage power supply following the timing signal repetition rate and duty cycle. A high voltage sealed connector is used as feed-through.

The power required to charge and to discharge the electrode equivalent capacitance C_{plate} , at the voltage V and repetition frequency f is approximately given by the formula [2]:

$$P = \frac{f \cdot C \cdot V^2}{2}$$

Numerical values considered for the design, are summarized in Table 1.

Table 1: Design parameters for the chopper power circuit.

Maximum voltage:	10kV
Rise/fall time under	100ns
Duty cycle variable from	0 to 100%
Repetition frequency	from few hertz to 1kHz

where C includes C_{plate} but also the output internal capacity of the switch and the equivalent capacitances of the cable and of the vacuum connector. This applies either for the power supply and the switch loss.

To fit the requirements, 10 Watt, off-the-shelf devices have been selected. A standard pulse/function generator AFG310 by Tektronix is used to drive the switch, while the main components of the system are:

- Power supply MPS10P10/24 by Spellman
- Solid state switch HTS151-03-GSM by Behlke
- Vacuum feed-through SHV-20 by Caburn
- Coaxial cable HTC-50-7-2 by Draka

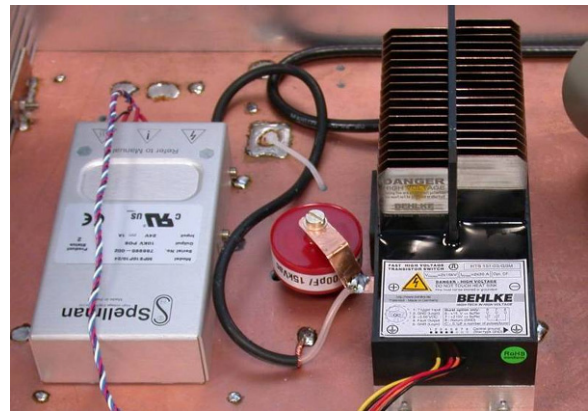

Figure 6: The power supply and the switch.

Figure 6 shows the high voltage switch, the power supply and the 1nF buffer capacitance in the rack. The solid state switch consists of two identical mosfet switching paths that form a so-called half bridge circuit configuration. Both switching paths are controlled by a common logic driver. The power supply can deliver up to 10kV, 1mA. The switch and the electrode are connected by a low loss coax cable. Great care was taken to assemble these modules into the rack. Special attention was given for grounding and shielding all the components.

Mechanical Design

The mechanical assembling of Figure 7 was designed to test the feed-through in operating conditions and to verify the assembling concept and the plate alignment.

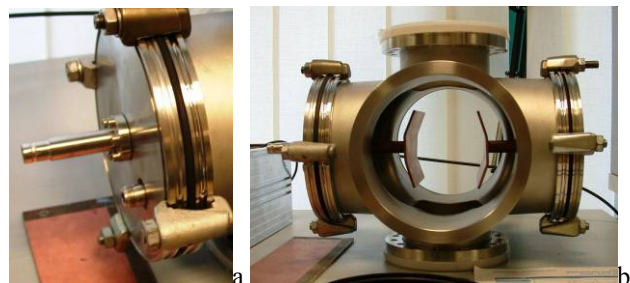

Figure 7: Feed-through and electrodes assembled in the cross section.

A standard beam line cross section with six gates was available at the Lab and was used to host the electrodes. Each electrode is constituted of a plate of 3mm thick copper sheet supported by a copper column. They are inserted from opposite sides and each one is supported by its vacuum flange. The ground electrode is connected directly to the flange while the polarized plate is brazed to the feed-through connector. The ceramic feed through is a standard 20kV single ended coaxial SHV connector, DN16CF already flanged. A capacitive pick-up is inserted near to the feed-through to be used to check the pulse presence, but the alarm board still has to be developed.

EXPERIMENTAL RESULTS

A total capacitance of about 30pF was measured at the feed-through connector input. The cable adds some 70 pF and the data sheet gives a value of 30 pF for the switch output capacitance. With less than 150 pF, the system should reach a repetition rate of 1 kHz but the measured operating range (Figure 8) is smaller, and is limited by the current of the high voltage power supply.

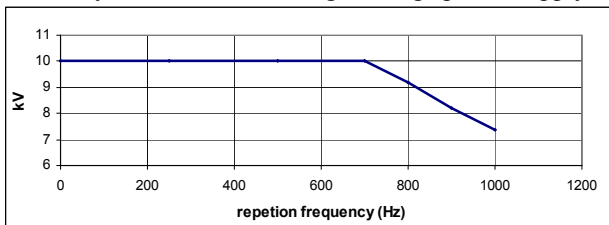

Figure 8: Prototype operating range.

A 20 W power supply will then be installed in the final rack, in order to reach the required repetition rate. No upgrade is foreseen for the switch as it had already been ordered with an option that let it dissipate up to 100 W.

Measurements of the transient times confirmed the data sheet performances: rise and fall times around 30 ns, as shown in Figure 9.

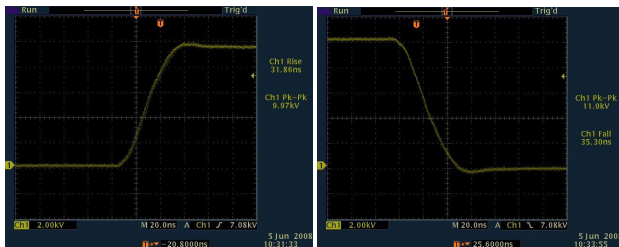

Figure 9: Rise and fall times.

A long time test of one week (@ 10kV, 800 Hz, 50% duty cycle) was also performed to check the circuit reliability and the stability of the pulse parameters. The amplitude stability is better than 1%, and no changes were observed in the delay between the driver and high voltage edges, which is of 160 ns as shown in Figure 10a, which also shows the 10 kV pulse shape at 700 Hz, 50% duty cycle and the pick-up response.

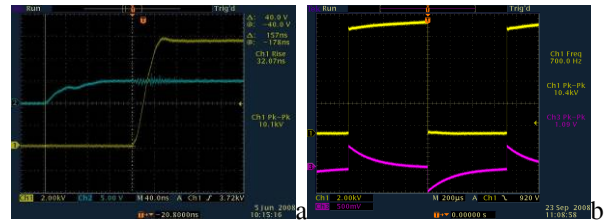

Figure 10: Pulse jitter (a) and shape (b yellow) @700 Hz, 50% dc, 10 kV. Pick-up response (b violet).

CONCLUSION AND PERSPECTIVES

The pulse amplitude, jitter and transition time measured on the prototype fulfil the requirements, while a more powerful high voltage supply is required to achieve a 1 kHz repetition rate. A complete system (electronics and electrodes) is available today for beam tests and next efforts will be dedicated to the design of the alarm control card and of the computer control interface and to the manufacture of the final mechanical ensemble to be installed on the Spiral2 injector.

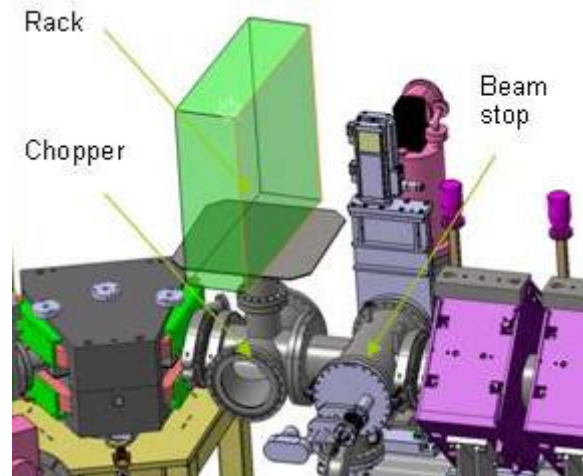

Figure 11: The chopper and beam stop line section with room reserved for the electronics rack.

AKNOWLEDGEMENTS

We would like to thank F. Gobin and Ch. Contrepois who have studied the low energy line integration and defined all interfaces between different devices.

INFN LNS is member of the SPIRAL 2 Preparatory Phase. This work is supported by the European Commission within the 7th Framework Program: project n. 212692.

REFERENCES

- [1] Behlke, high voltage switch application note
- [2] L. Calabretta et al: The radiofrequency pulsing system at INFN-LNS: Proceedings of Cyclotrons 2001, East Lansing, Michigan, USA