

Commissioning Results of the new BPM Electronics of the ESRF booster Synchrotron

Manuel Cargnelutti, Instrumentation Technologies
Kees Bertus Scheidt, ESRF

Presentation outline

- The ESRF Booster Ring
- Installation of the new BPM electronics
- Commissioning results
- Conclusions

The ESRF Booster Ring

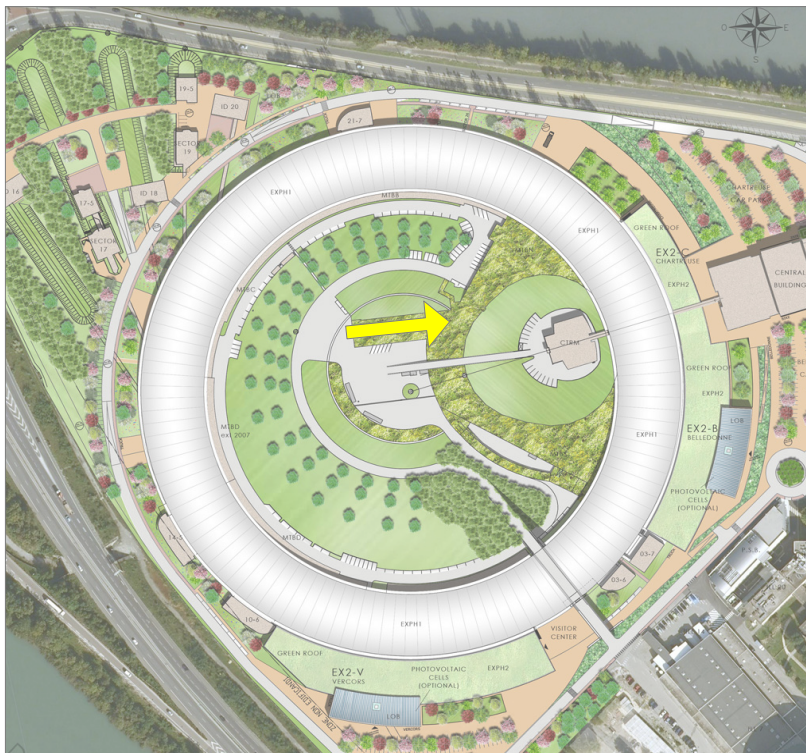

Pre-Injector LINAC
from 0 to 200 MeV

The ESRF Booster Ring

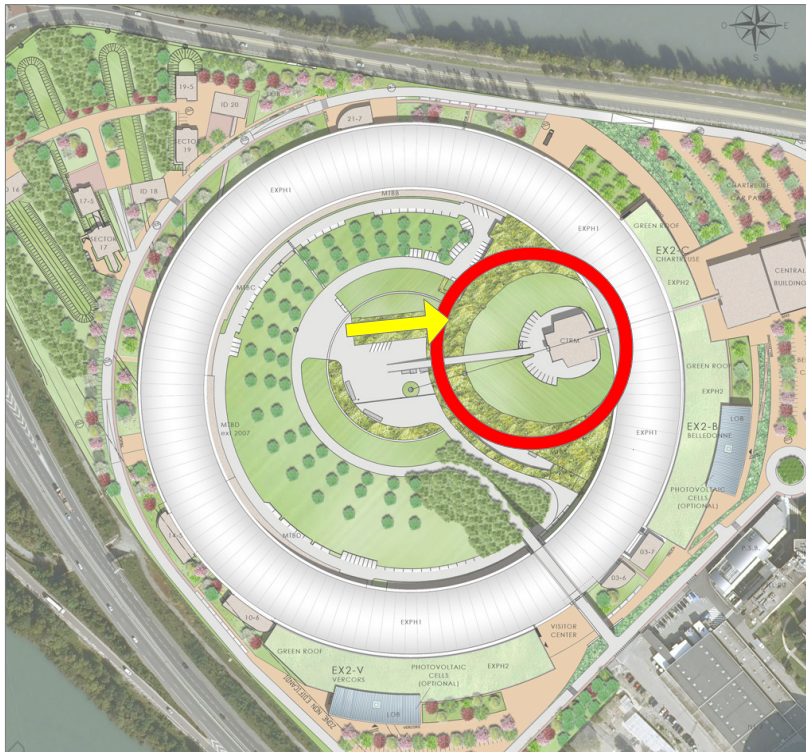

Pre-Injector LINAC

from **0 to 200 MeV**

Booster Synchrotron

200 MeV → 6 GeV

50 ms (50000 turns) acceleration cycle

1 μ s orbit time

current from **2.5 mA** down to **μ A**

The ESRF Booster Ring

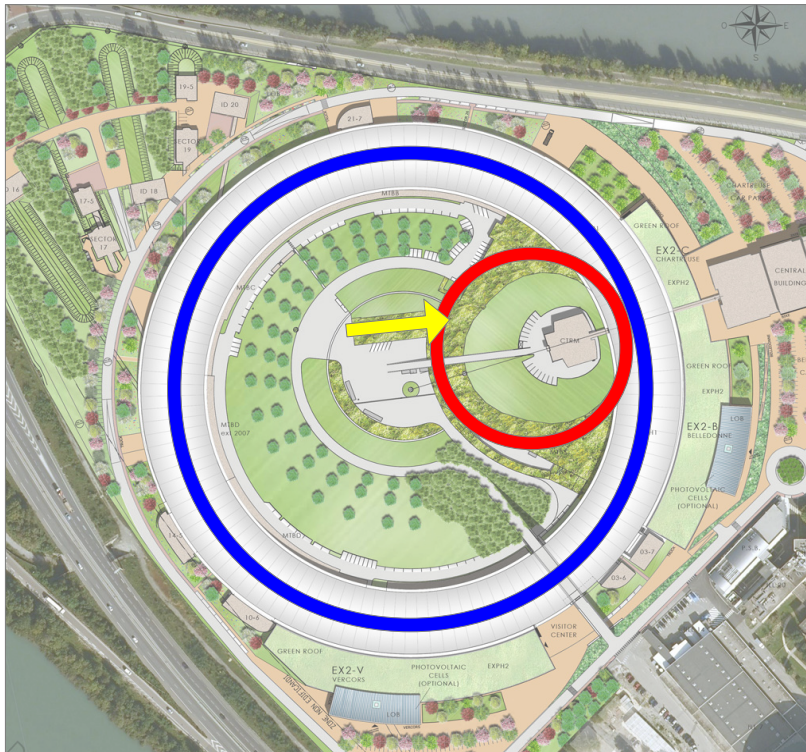

Pre-Injector LINAC

from **0 to 200 MeV**

Booster Synchrotron

200 MeV → 6 GeV

50 ms (50000 turns) acceleration cycle

1 μ s orbit time

current from **2.5 mA** down to **μ A**

Storage Ring (200 mA)

The ESRF Booster Ring

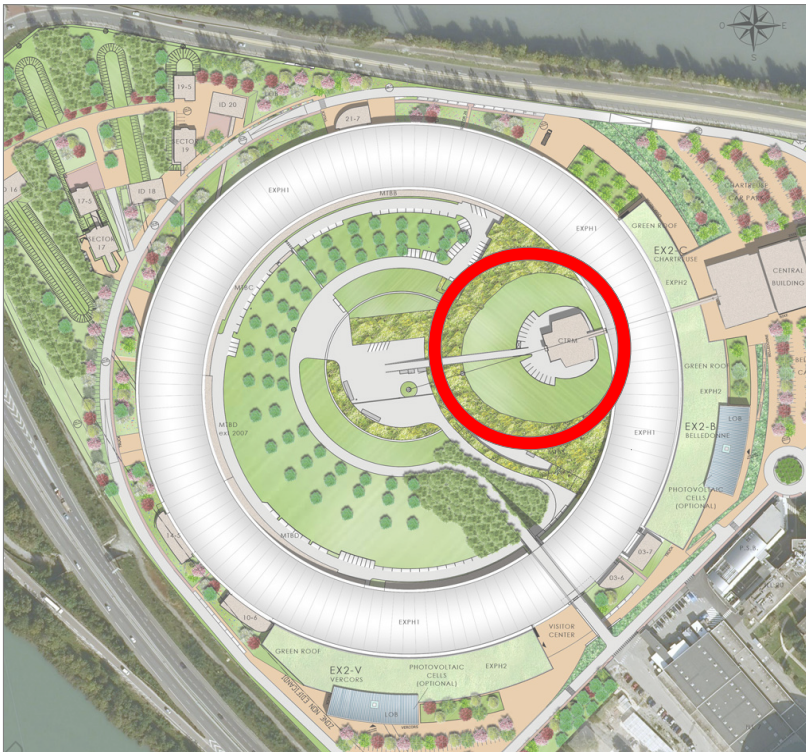

75 BPM blocks

25 years old electronics

Need new BPM electronics

What kind of electronics?

- + Good Price/Performance
- + Turn-By-Turn data
- + Easy to use
- + No maintenance required

What kind of electronics?

- + Good Price/Performance
- + Turn-By-Turn data
- + Easy to use
- + No maintenance required



Libera Spark

What kind of electronics?

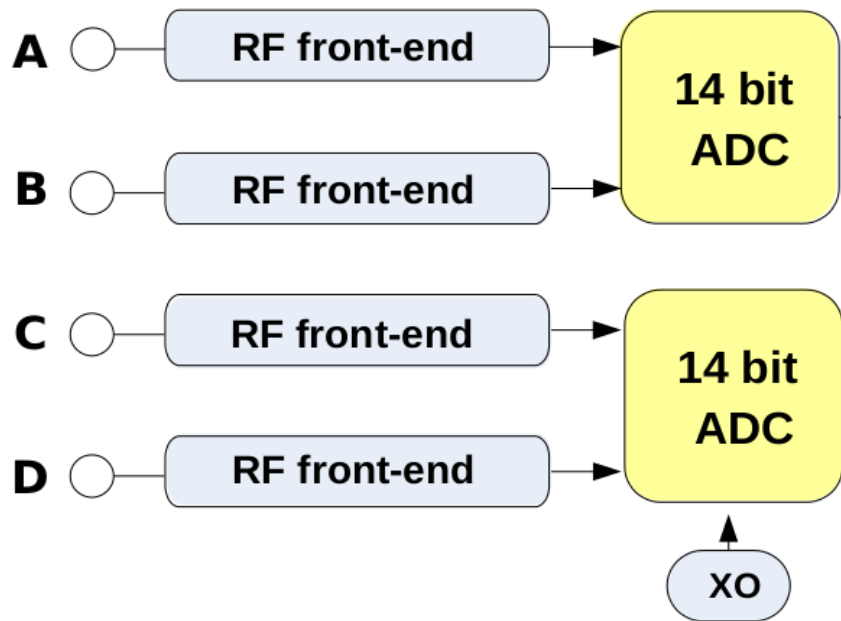

What kind of electronics?

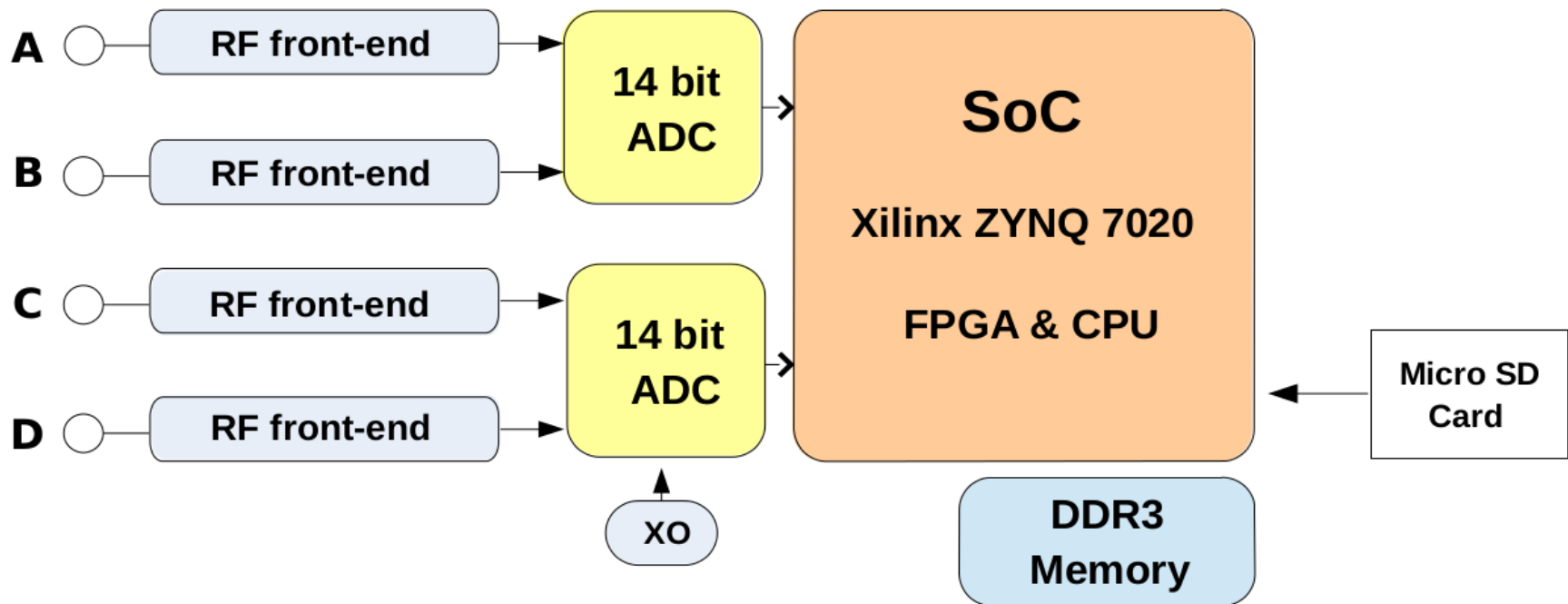

What kind of electronics?

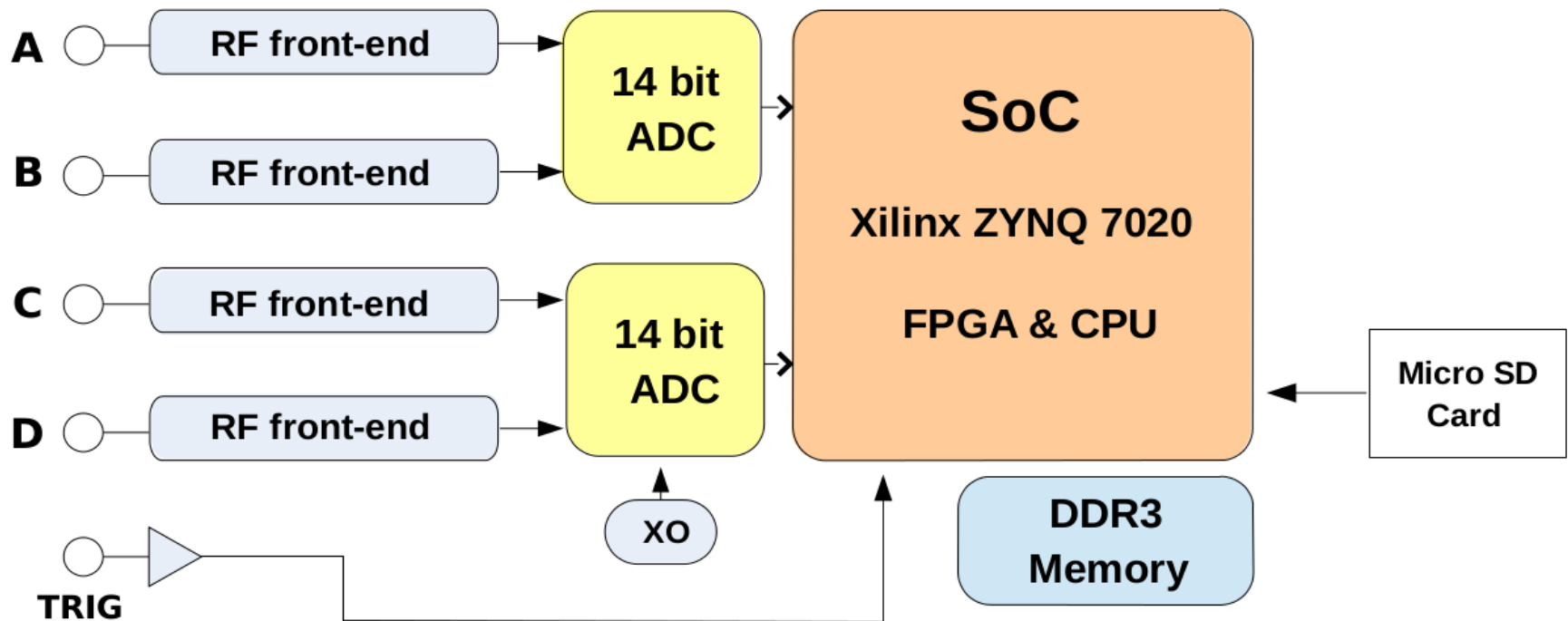

What kind of electronics?

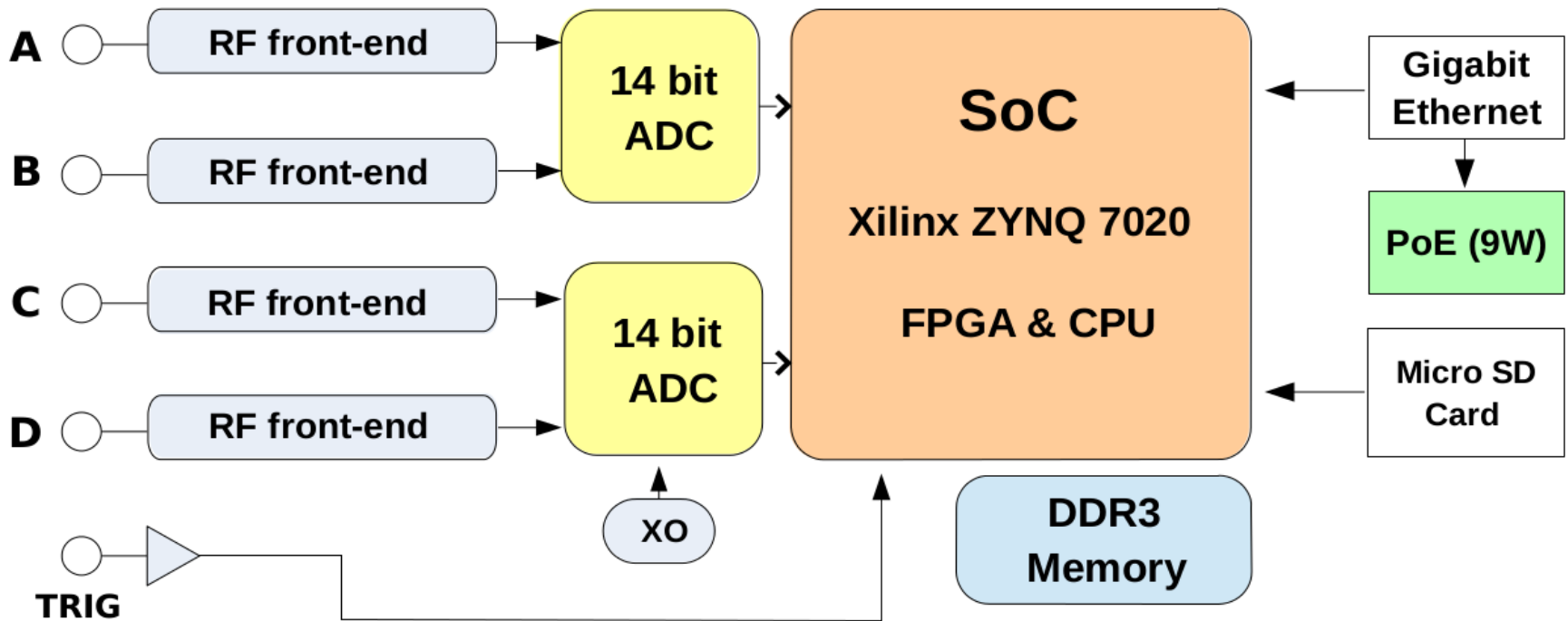

Installation

- Installation in the tunnel
- Radiation dosimetry tests (>6 months) shown very low radiation dose
- 3 m long RF cables
- Powered with Ethernet cable



Integration in the Control System



Libera Spark

Integration in the Control System

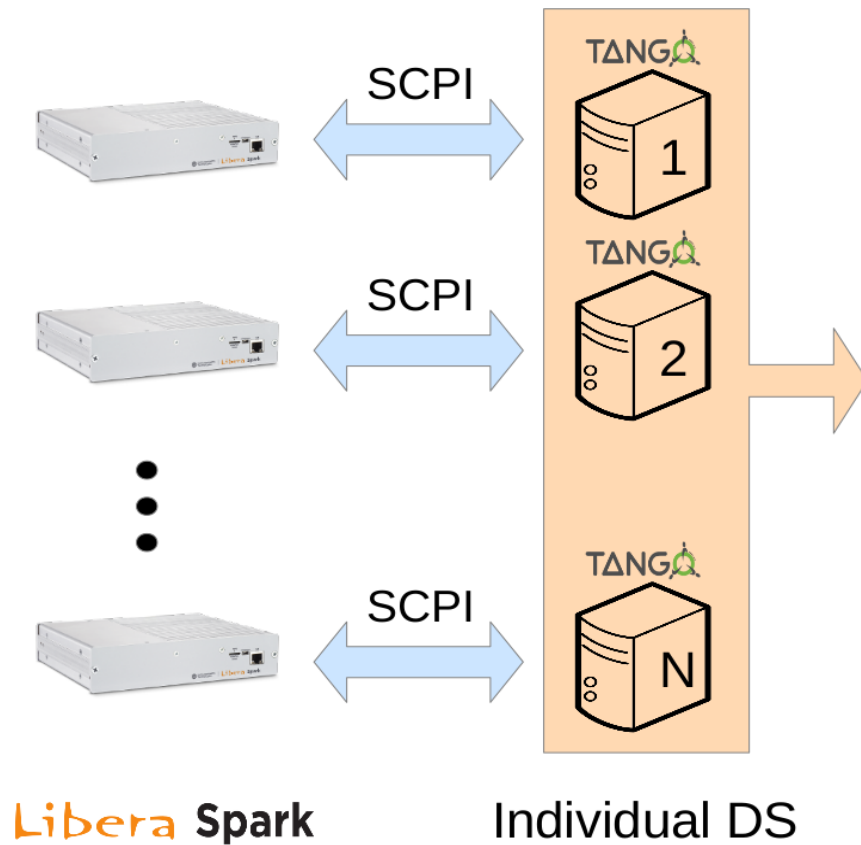

Integration in the Control System

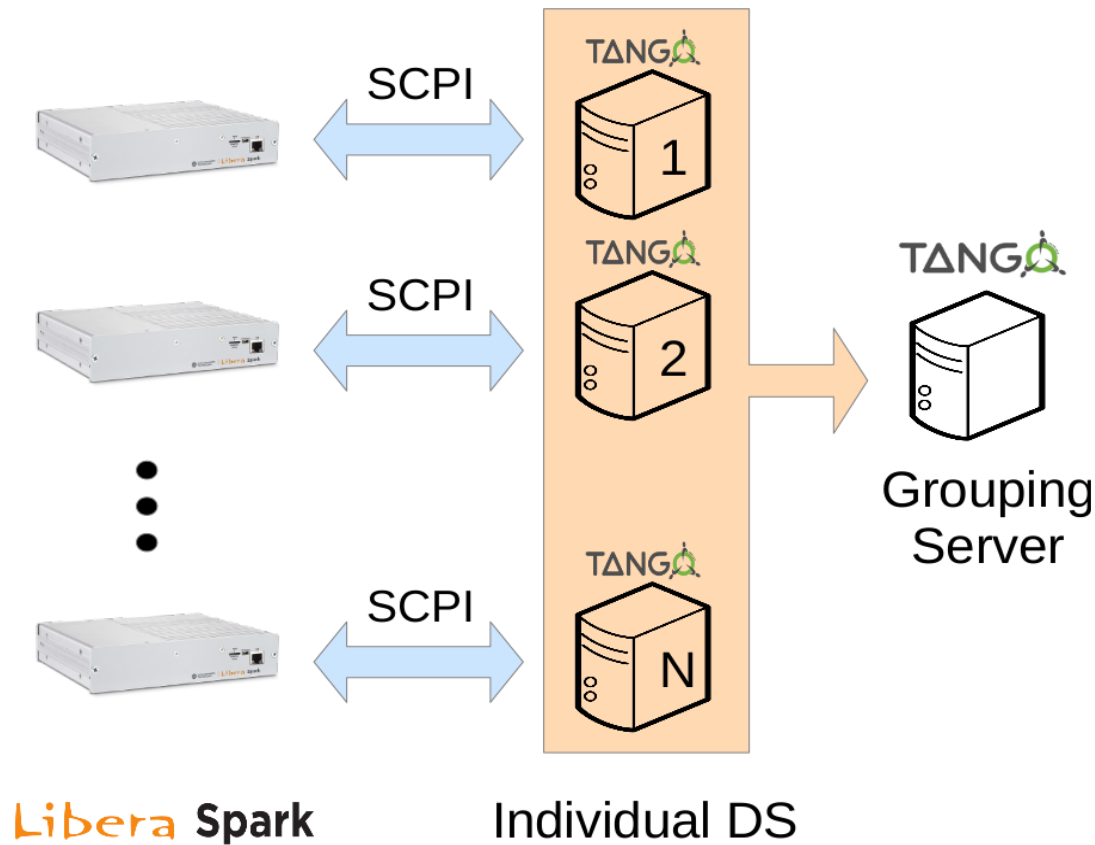

Integration in the Control System

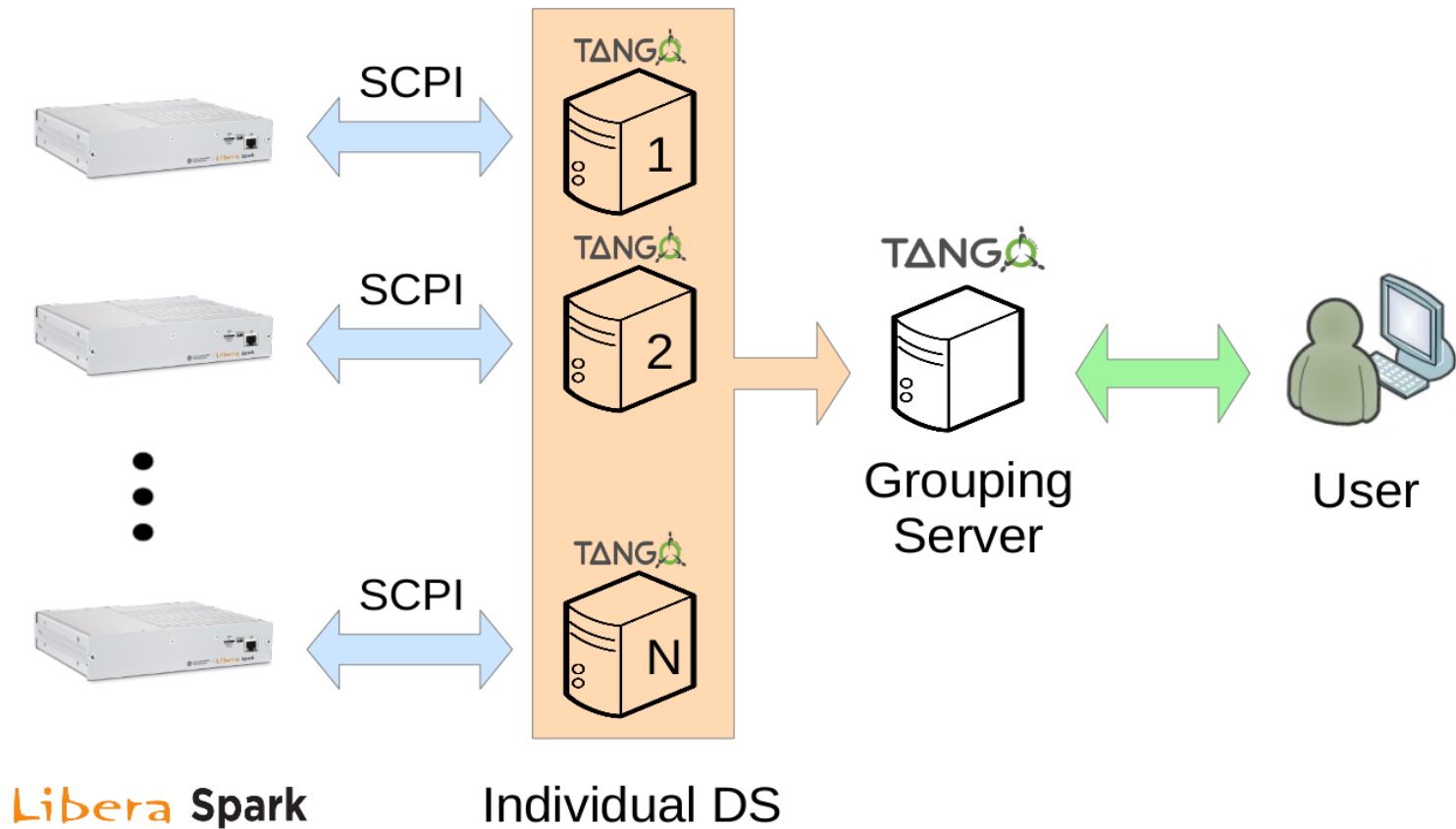

Commissioning Results

1) Synchronization with the beam arrival

- Trigger is the same signal which goes around the ring
- 2 μs difference between first and last unit (2 turns)

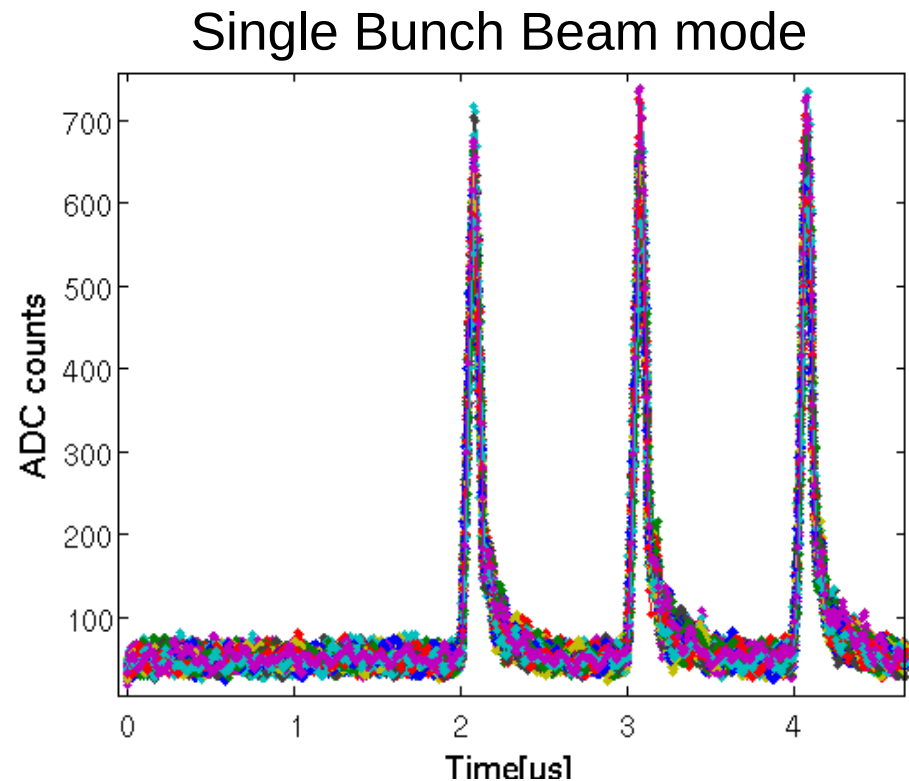

1) Synchronization with the beam arrival

- Trigger is the same signal which goes around the ring
- 2 μs difference between first and last unit (2 turns)
- Adjusted with each unit **Trigger Delay** on the ADC buffer

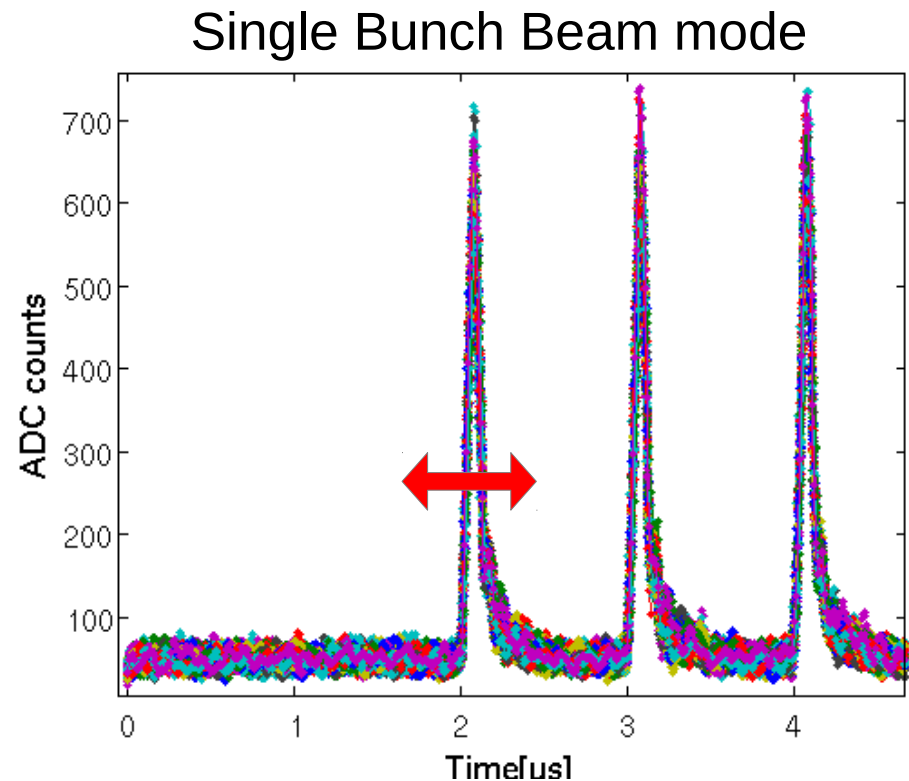

2) Tune monitor with Turn-by-Turn data

Turn-by-Turn position (1 μ s)

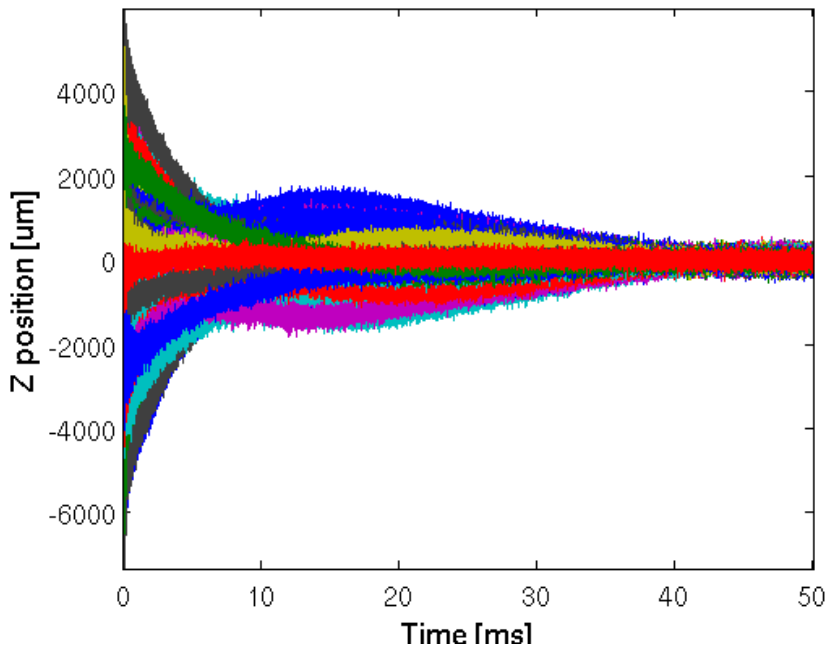

2) Tune monitor with Turn-by-Turn data

Turn-by-Turn position (1 μ s)

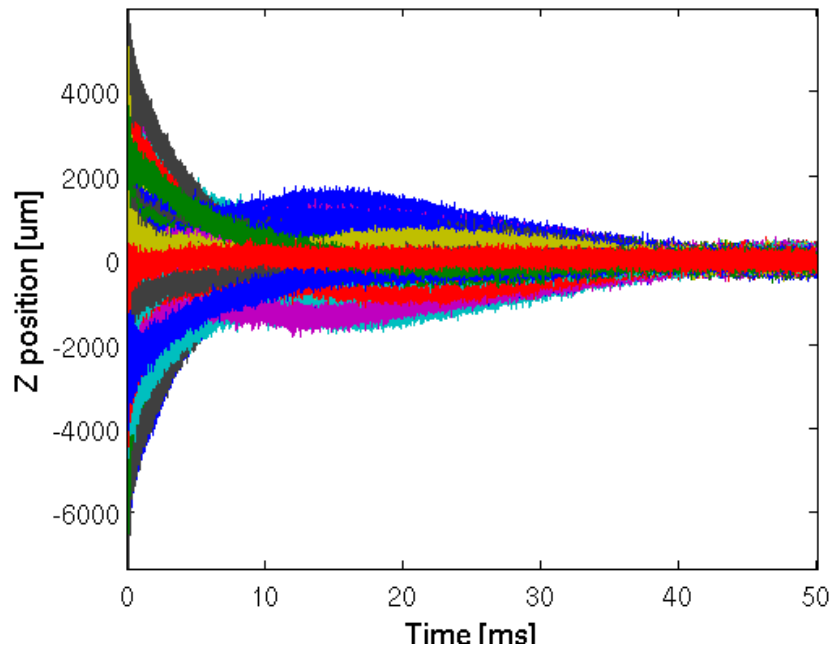

Vertical Tune monitor

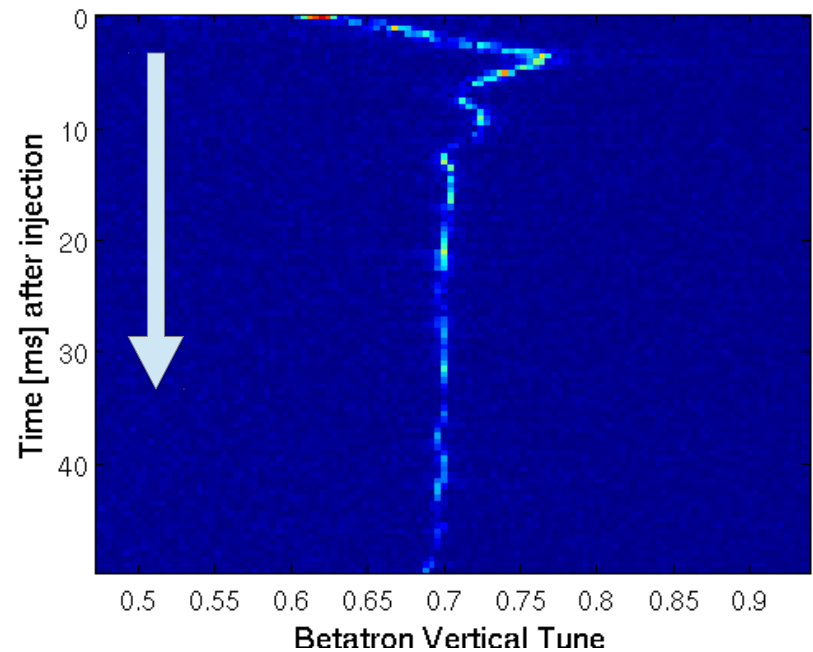

FFT in 0.5 ms data slices

3) Position resolution vs Beam current

- Booster operating with long-pulse mode (80% fill pattern)
- Current was reduced in steps from **2.5 mA** to **μA**

3) Position resolution vs Beam current

- Booster operating with long-pulse mode (80% fill pattern)
- Current was reduced in steps from **2.5 mA** to μA
- **Sum signal**: estimate real current intensity

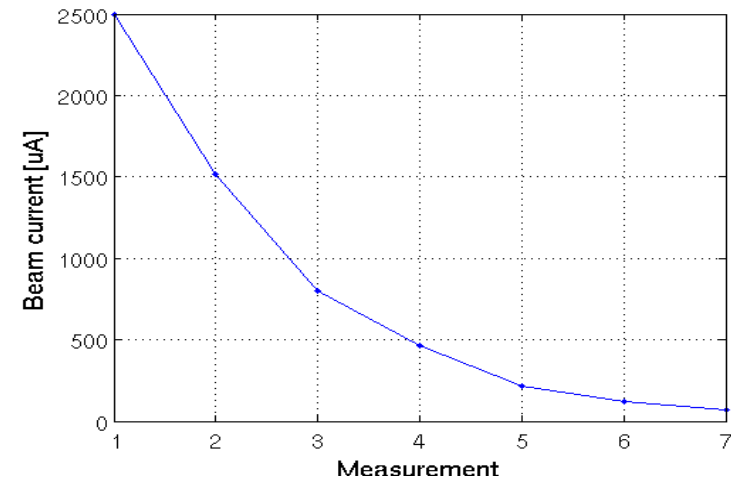

3) Position resolution vs Beam current

- Booster operating with long-pulse mode (80% fill pattern)
- Current was reduced in steps from **2.5 mA** to μA
- **Sum signal**: estimate real current intensity
- **X Z position**: estimate resolution with RMS

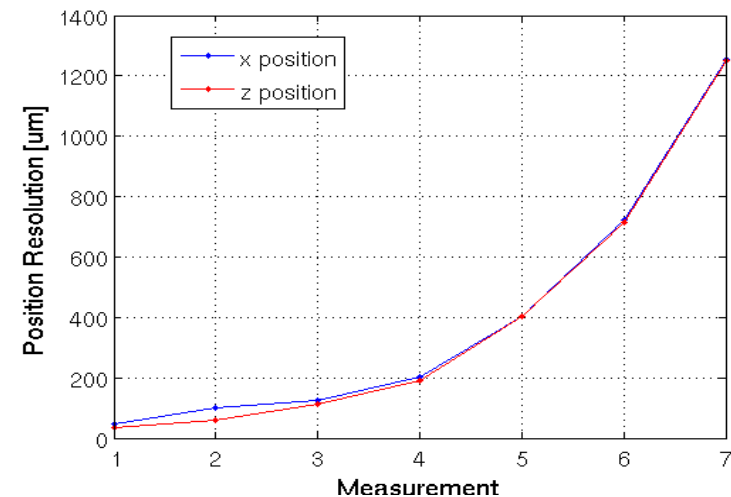
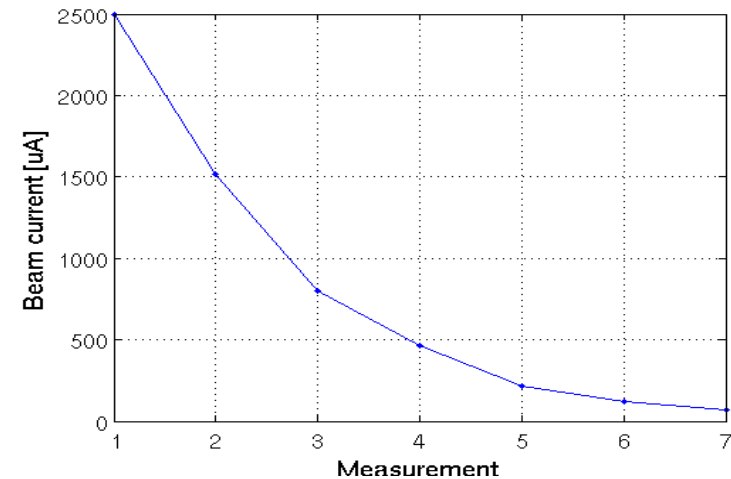

Decimated T-b-T data

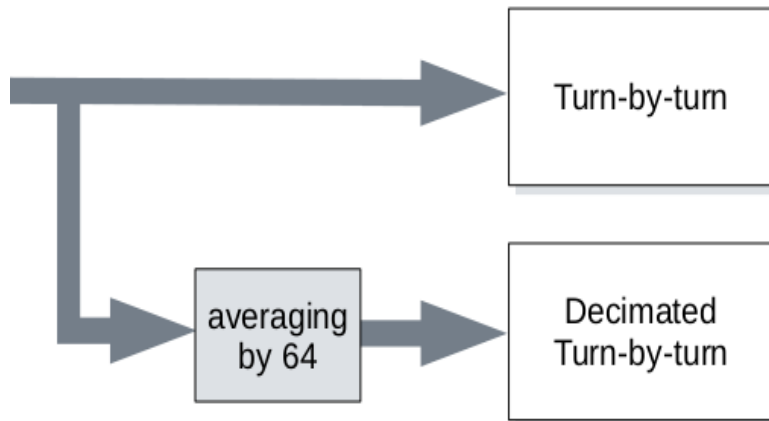

1 sample = 1 turn = 1 μ s

1 sample = 64 turns = 64 μ s

Decimated T-b-T data

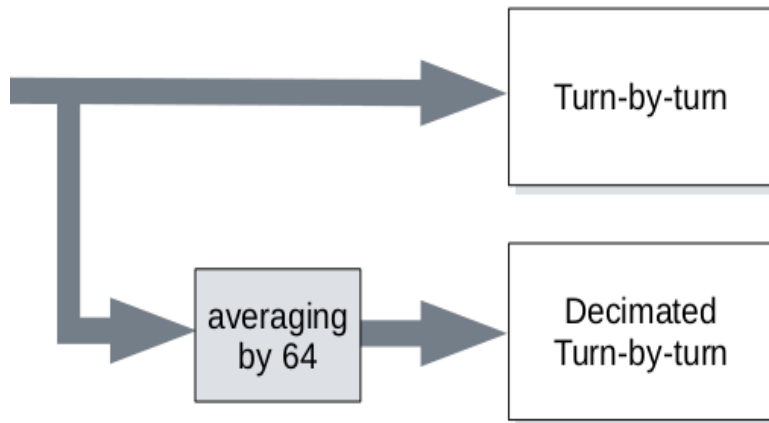

1 sample = 1 turn = 1 μ s

1 sample = 64 turns = 64 μ s

Motivation?

4) Position measurements

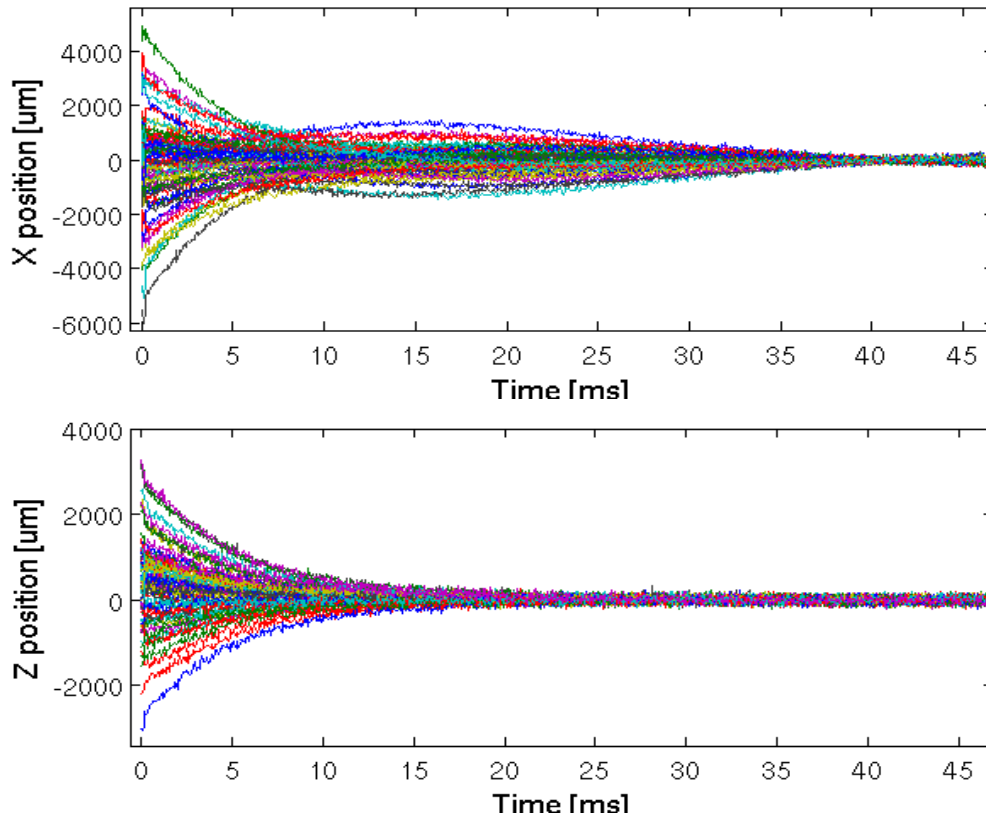

Motivation?

Reduced bandwidth
means reduced
noise contribution

5) Orbit measurements

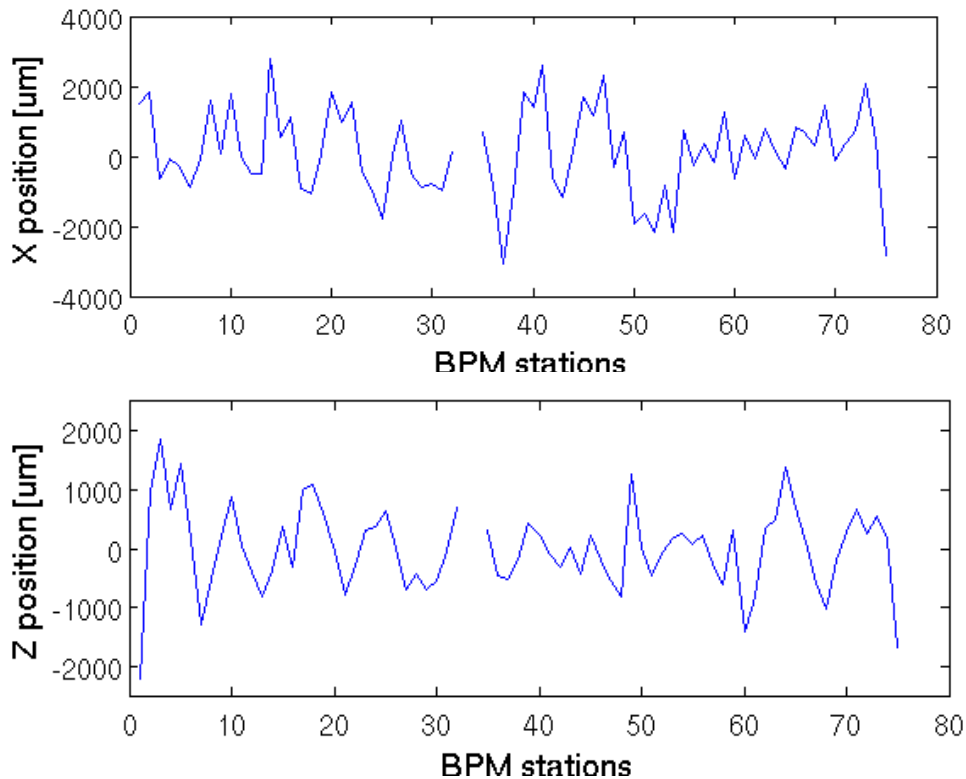

Motivation?

Reduced amount of
data to be transferred
over the network

6) Extraction process

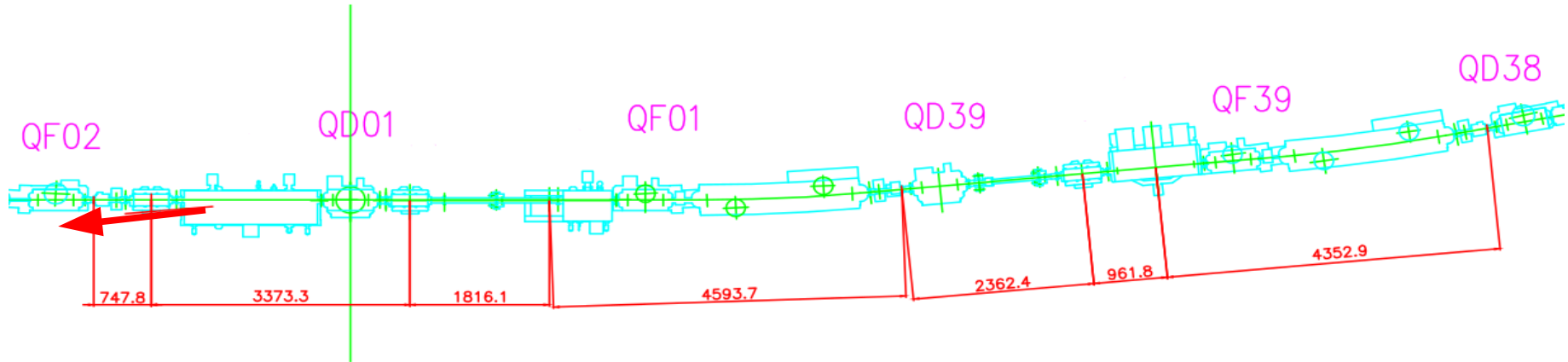

6) Extraction process

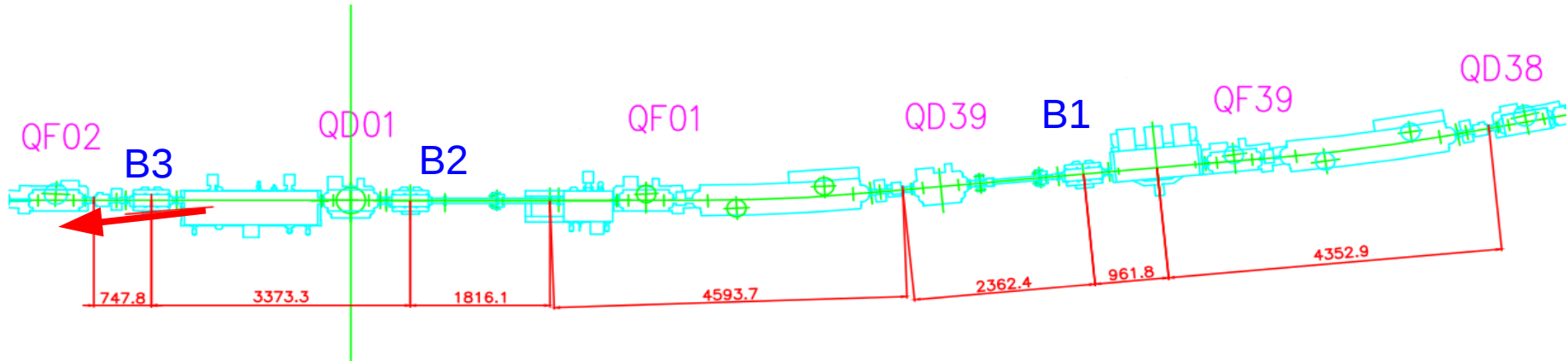

- Three bumpers (**B1**, **B2** and **B3**) create an horizontal bump 1.5 ms before extraction

6) Extraction process

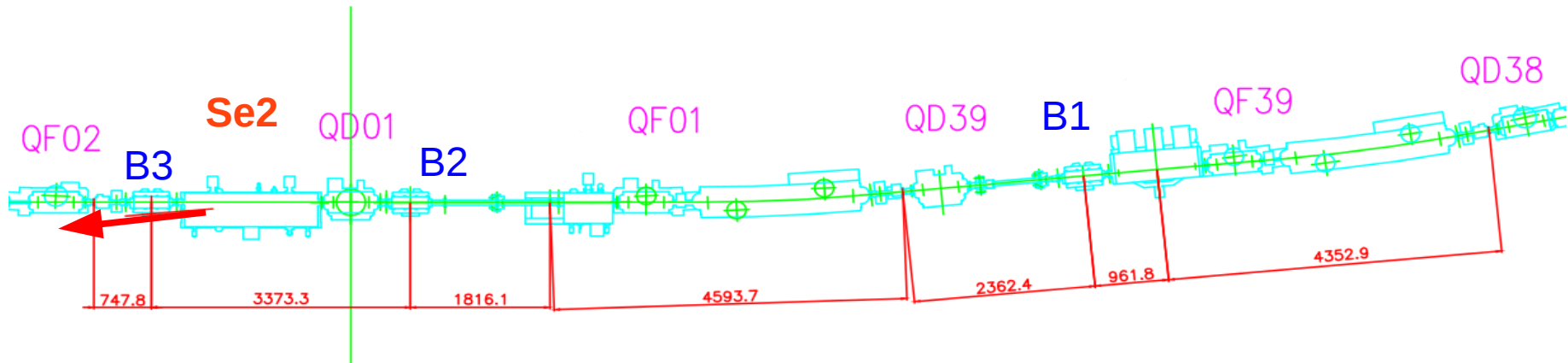

- Three bumpers (**B1**, **B2** and **B3**) create an horizontal bump 1.5 ms before extraction
- This moves the beam closer to the extraction septum magnet **Se2**

6) Extraction process

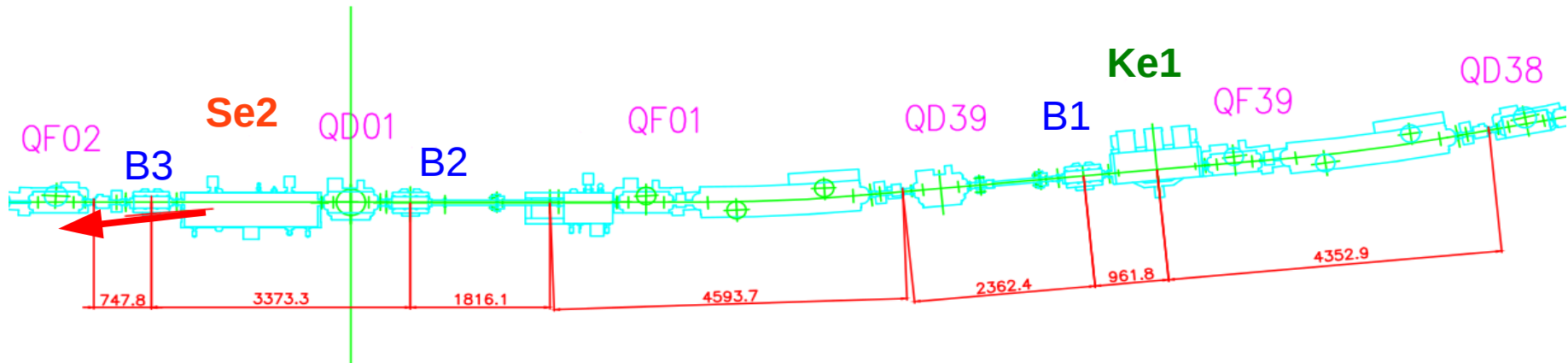

- Three bumpers (**B1**, **B2** and **B3**) create an horizontal bump 1.5 ms before extraction
- This moves the beam closer to the extraction septum magnet **Se2**
- The fast kicker **Ke1** extracts the beam in one turn

6) Extraction process

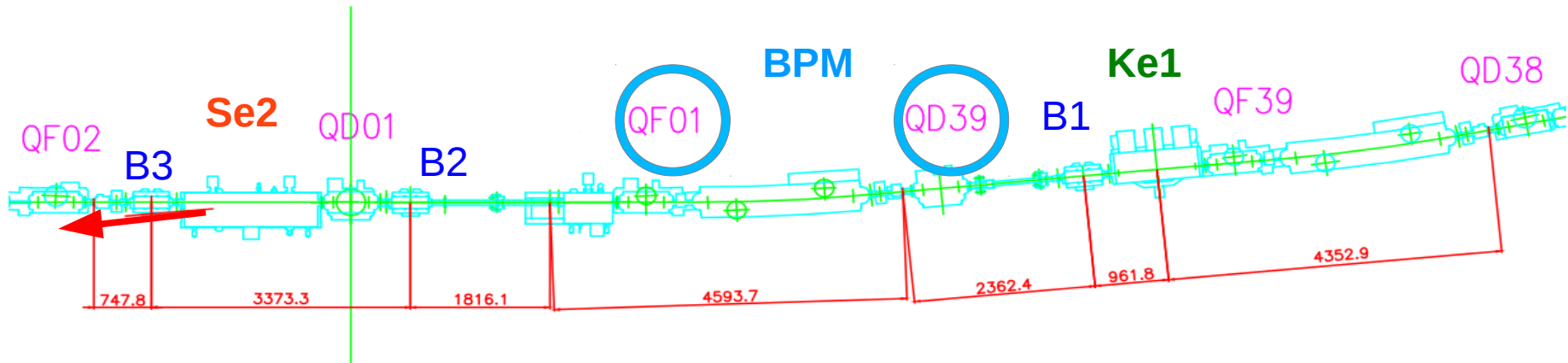

- Three bumpers (**B1**, **B2** and **B3**) create an horizontal bump 1.5 ms before extraction
- This moves the beam closer to the extraction septum magnet **Se2**
- The fast kicker **Ke1** extracts the beam in one turn

6) Extraction process

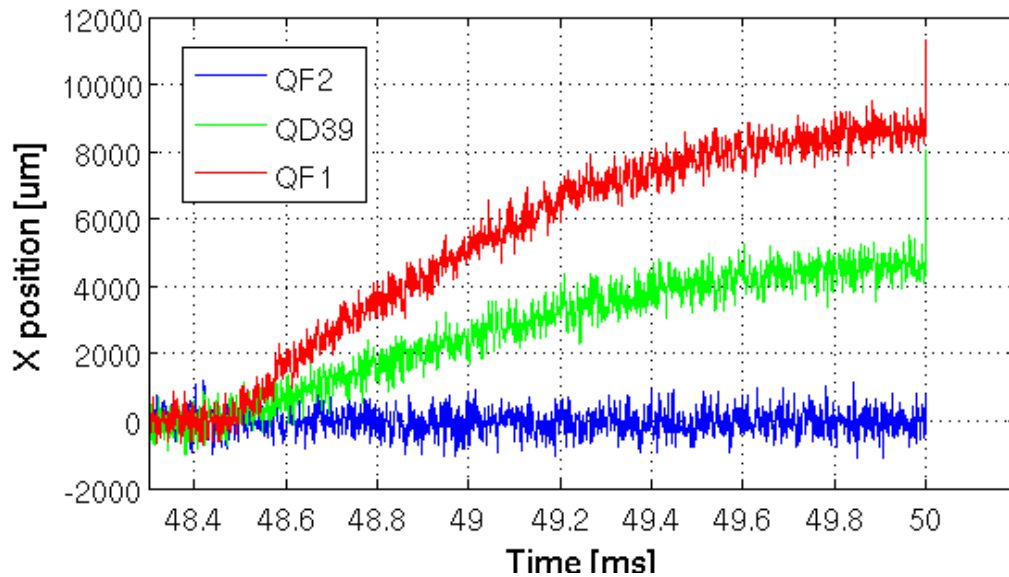

1.5 ms local bump

6) Extraction process

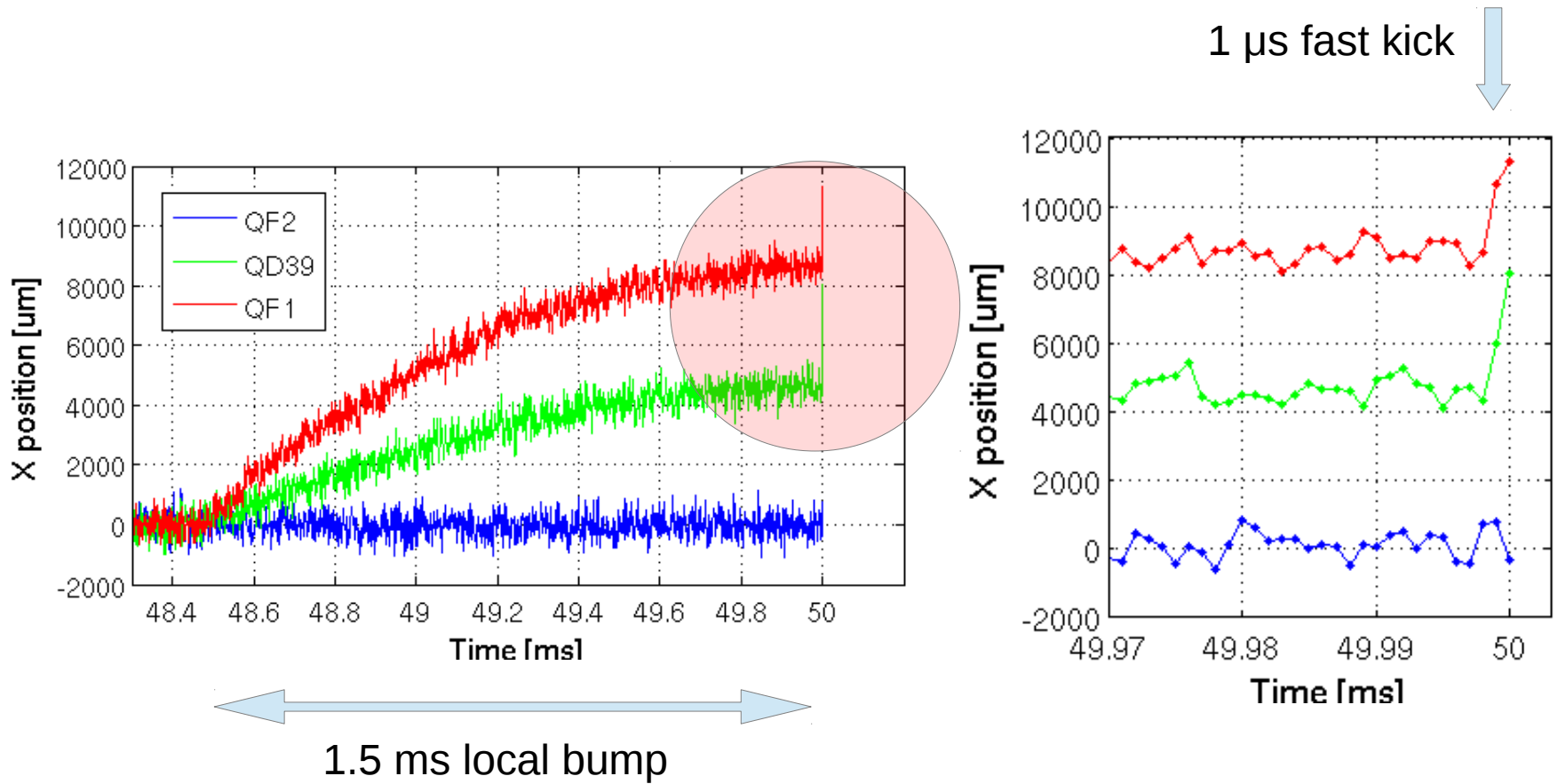

Conclusions

- Commissioning of **75** new BPM electronics
- Installation, Integration and Measurements: **2 weeks**
- ADC, T-b-T and Decimated data proven to be very useful
- Libera Spark is a cost-effective and valuable solution



Libera Spark

Thanks for your attention!

manuel.cargnelutti@i-tech.com