

# High Beam Intensity Harp Studies and Developments at SNS\*

Willem Blokland

Beam Instrumentation Team  
Spallation Neutron Source  
Oak Ridge National Laboratory



Sixth International Particle  
Accelerator Conference,  
Virginia, USA , May 3-8, 2015

\*ORNL/SNS is managed by UT-Battelle, LLC, for the U.S.  
Department of Energy under contract DE-AC05-00OR22725

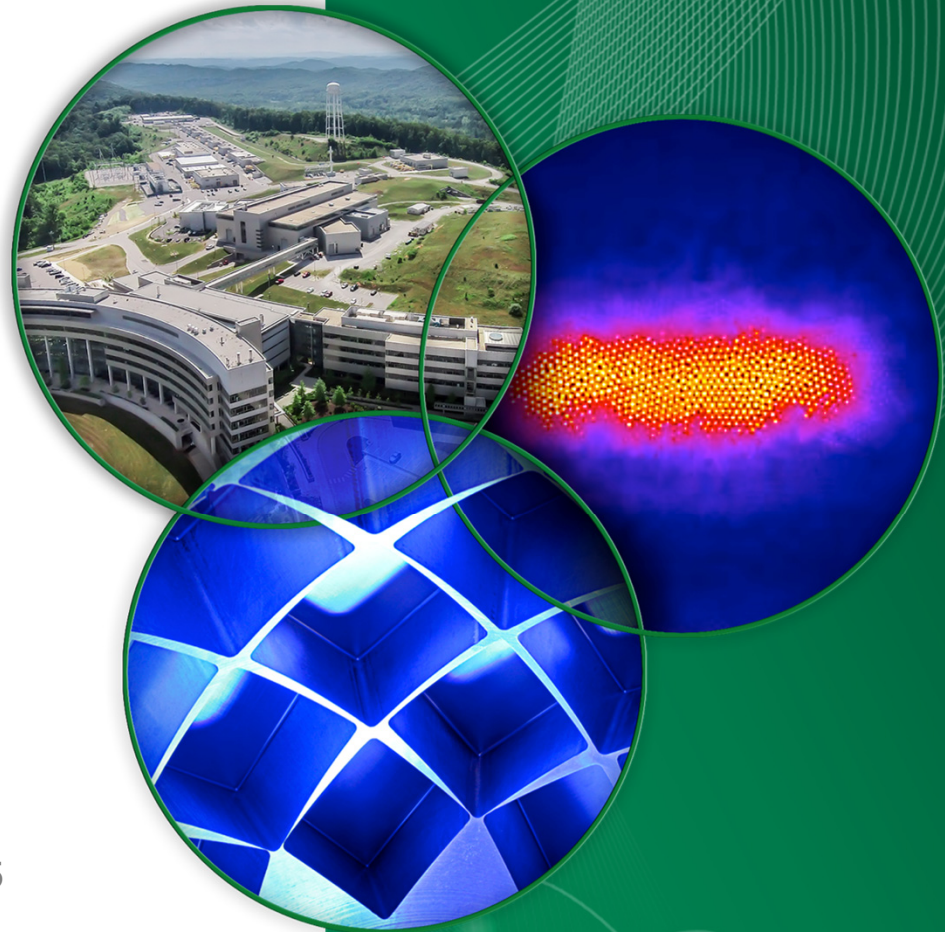

# Introduction

- SNS steers a 1.4 MW 1 GeV proton beam onto a mercury target to create neutrons for material research
- The harp is used to measure the proton beam's profile
  - 3 planes (~35 cm wide)
  - 30 wires per plane
  - 100  $\mu\text{m}$  tungsten wire

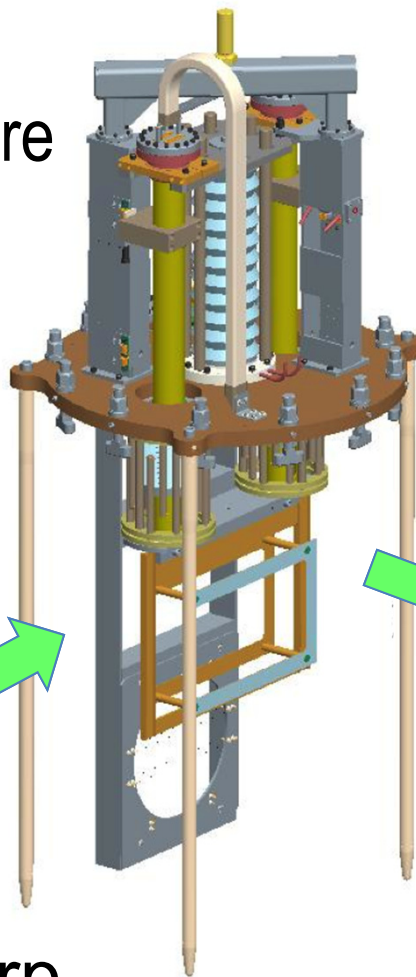
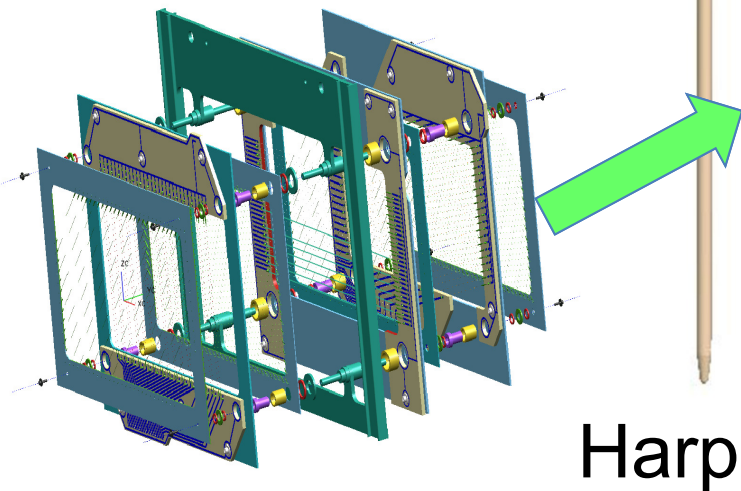

Harp

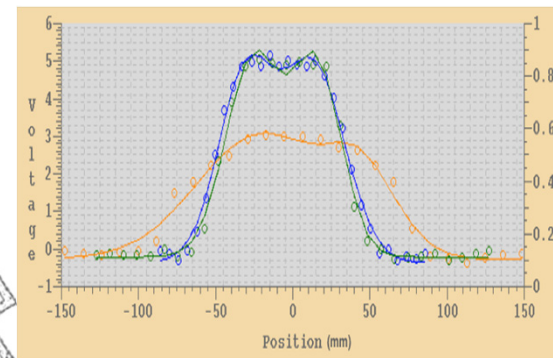



# Studies

## The motivation:

- Understand the harp signals and quality of profile
- Help design the data acquisition system upgrade:
  - The harp electronics (sample-and-holds) gets saturated at high intensities (timing must be delayed)
  - The electronics is >10 years old, obsolete, and sometimes the hardware has to be reset

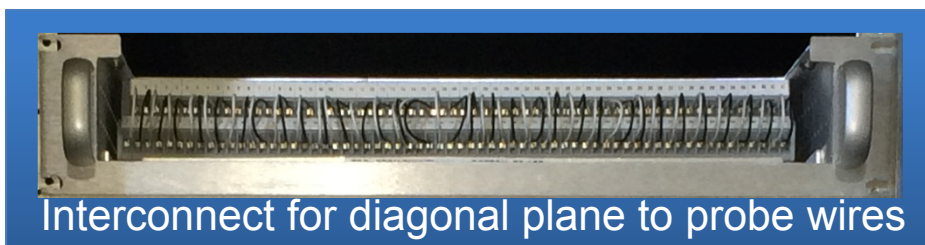

## Initial Studies:

- Wire signal strength
- Secondary Electron eMission
- Uniformity scan



Harp electronics

# Wire Signal Strength

What is the signal that is acquired?



We found that for a 2.5 uC beam pulse:

- Peak is 7.3 mV at 1M Ohm with 177 pC integrated charge
- Cable capacitance is  $C = Q/V$   
 $= 177 \text{ pC} / 7.3 \text{ mV} = 24.1 \text{ nF}$
- Signal range (diag):
  - 1.5 pC to 1.5 nC
  - 60  $\mu\text{V}$  to 60 mV

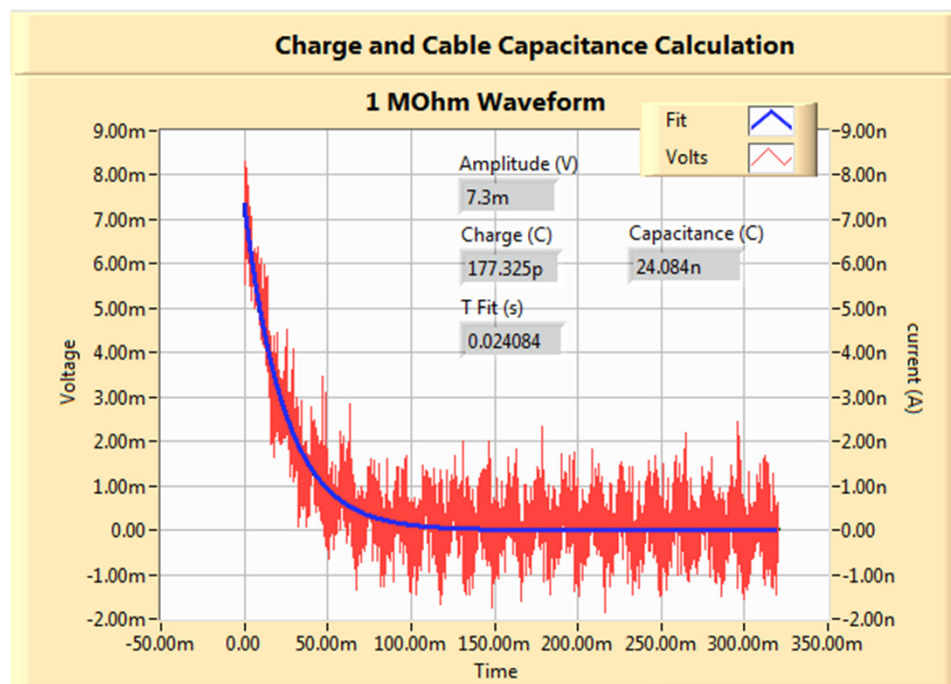

# Secondary Electron eMission (SEM)

How does the calculated SEM compare to the measured SEM?

SEM is the ratio of the measured charge from the wire with proton beam charge hitting the wire:

- Charge from the wire
  - As measured
- Proton beam charge,  $Q_p$ , hitting the wire
  - Calculate  $Q_p$  as fraction of the wire area of the profile over the total profile area times proton beam charge  $Q_b$

→ Estimated SEM = **0.07** ( $\pm 10\%$ )

→ Compare to model from Sternglass theory which predicts **0.15** (M. Plum). Accuracy about a factor of 4.

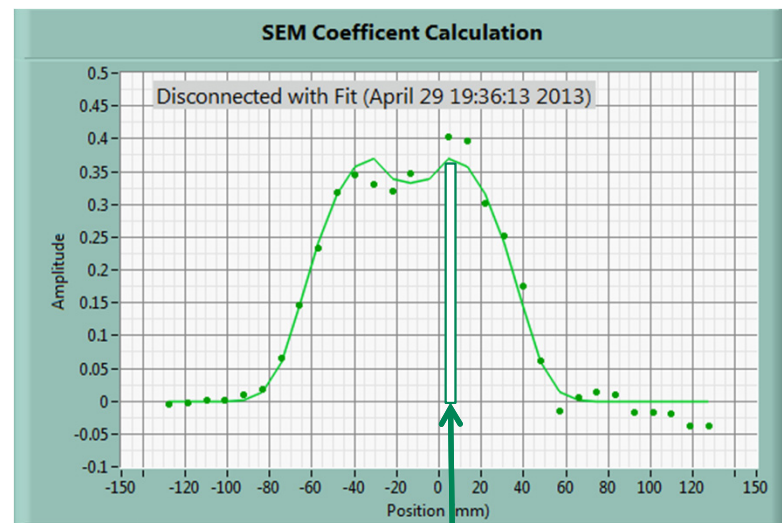

$$Q_p = \frac{V_i * W_{wire}}{\sum_{k=1}^N V_k * W_{spacing}} * Q_b$$

# Secondary Electron eMission (SEM)

How does the calculated SEM compare to the measured SEM?

SEM is the ratio of the measured charge from the wire with proton beam charge hitting the wire:

- Charge from the wire
  - As measured
- Proton beam charge,  $Q_p$ , hitting the wire
  - Calculate  $Q_p$  as fraction of the wire area of the profile over the total profile area times proton beam charge  $Q_b$

→ Estimated SEM = **0.07** ( $\pm 10\%$ )

→ Compare to model from Sternglass theory which predicts **0.15** (M. Plum). Accuracy about a factor of 4.

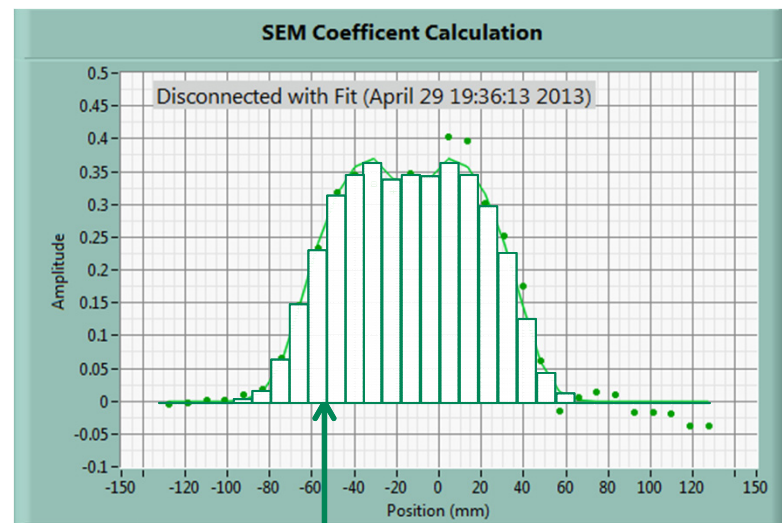

$$Q_p = \frac{V_i * W_{wire}}{\sum_{k=1}^N V_k * W_{spacing}} * Q_b$$

# Uniformity Scan

Does 25 GWh proton beam on target change the SEM across or along wires?

- Steer single turn beam across horizontal profile wires
- Steer single turn beam along one horizontal profile wire

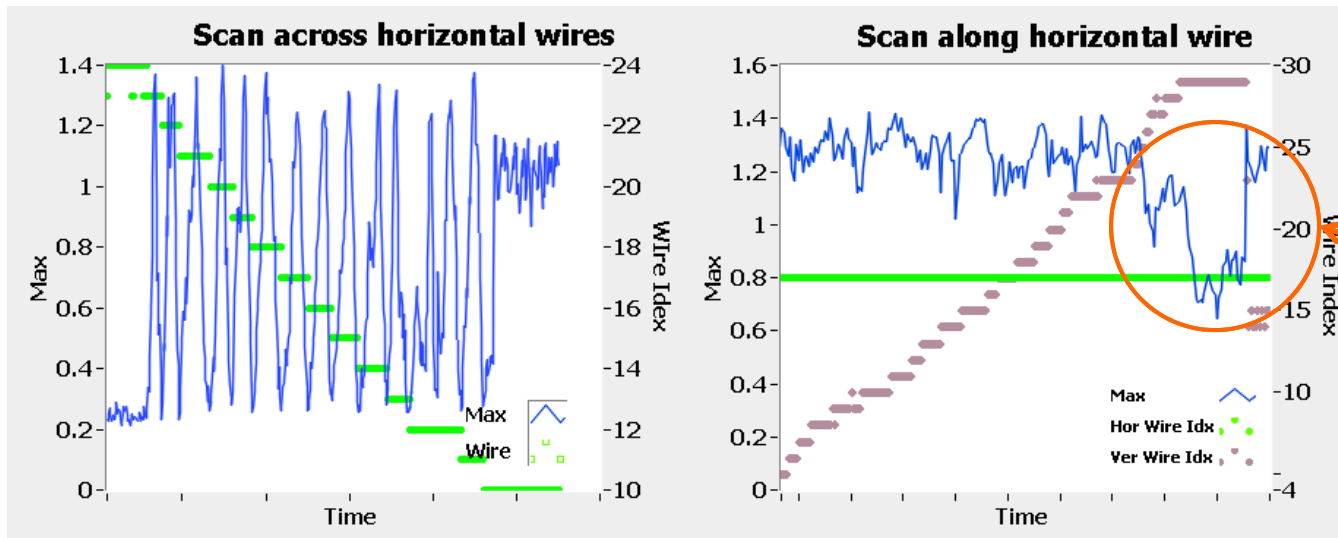

Real or lost beam?  
(beam is far outside normal trajectory)

- ~10% variation. We expect some variation due step size and beam jitter
- Plan to automate scan and redo to increase accuracy and track changes



# Data-acquisition Design for Harp

- Requirements:

- Main uses are tune-up and production beam (high intensity)
- Dynamic range of about 1:5000. Full intensity to about 1/50 (20 turns) and 1:100 per profile)
- 1 Hz update rate
- No Machine Protection function
- 90 Channels!
- Signal range 60 mV (up to 2x for ver) at  $\gg 50$  Ohm termination

- Resources:

- \$\$: Find a cost effective solution
- No electronics engineer: simple electronics solution
- cRIO, PXI, and PC platforms supported (e.g timing and EPICS)



# Data-acquisition

## Can we use cRIO and digitizers?

- \$10k for 96 channels of 16-bits at  $\pm 200$  mV to  $\pm 10$  V and up to 15 kS/ch/s

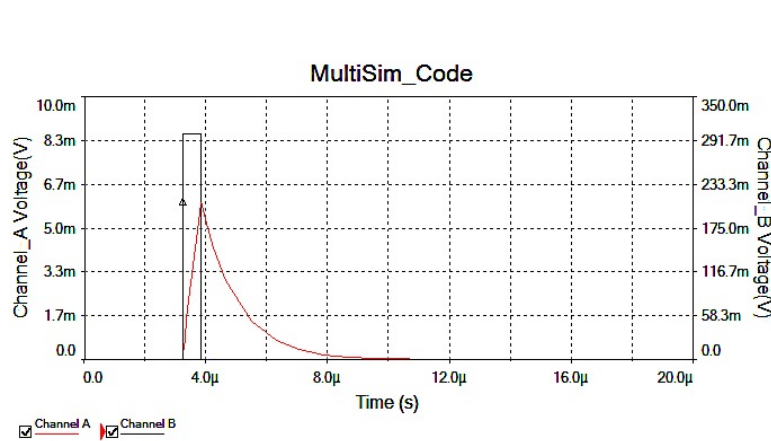

*50 Ohm termination:  
need fast digitizer*

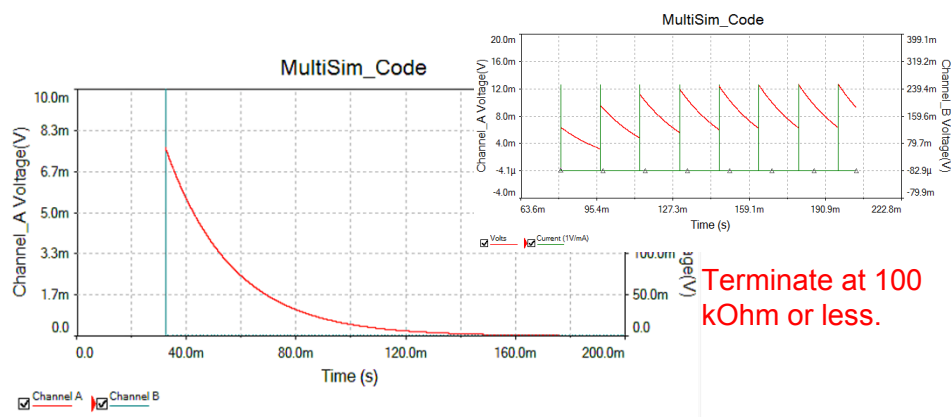

*1 MOhm termination: will  
charge up cable at 60Hz*

To sample at 15kS/s, we must smooth the charge-up peak (670 ns) to reduce sampling error

→ Use a passive filter

# Analog filter design

- Simulate a filter that smooths the rising edge of the pulse

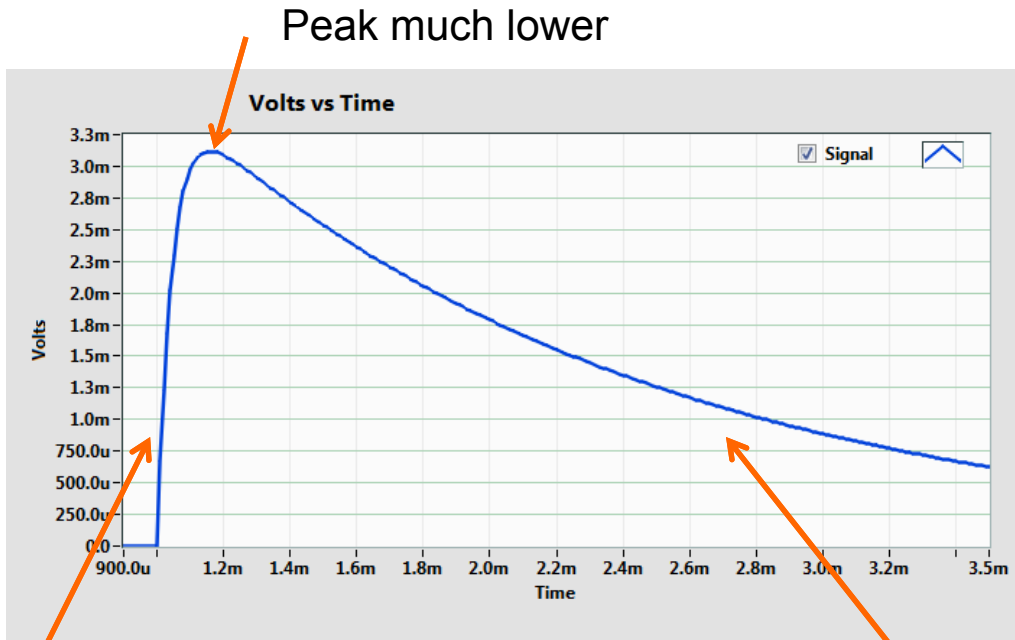

Ramp up is slowed (200  $\mu$ s) to minimize error due to the low sampling rate from 5% to 0.5%

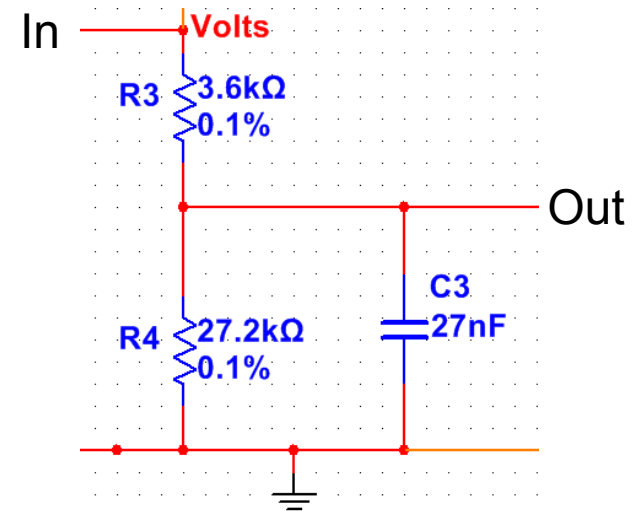

The RC circuit to slow the rising of signal

Decay fast enough to avoid charging up

# Harp signal with reference subtracted

Does the filter work as designed?

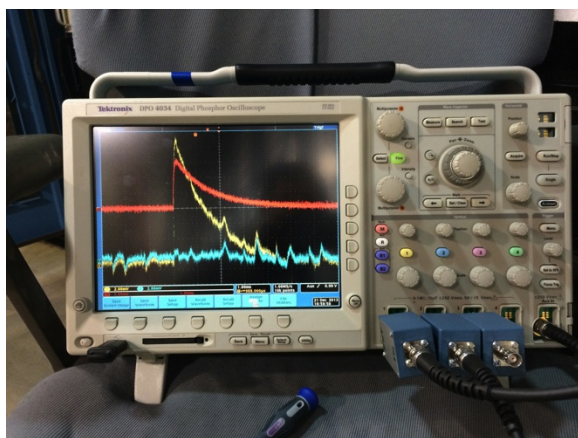
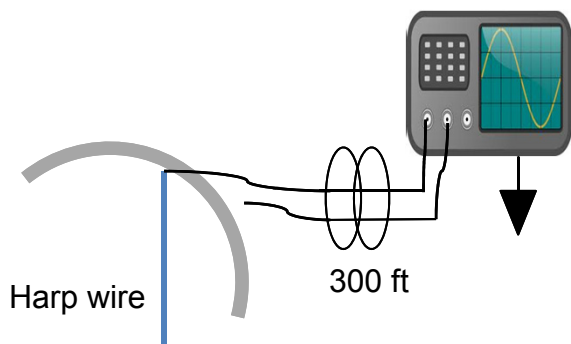

Scope measurement

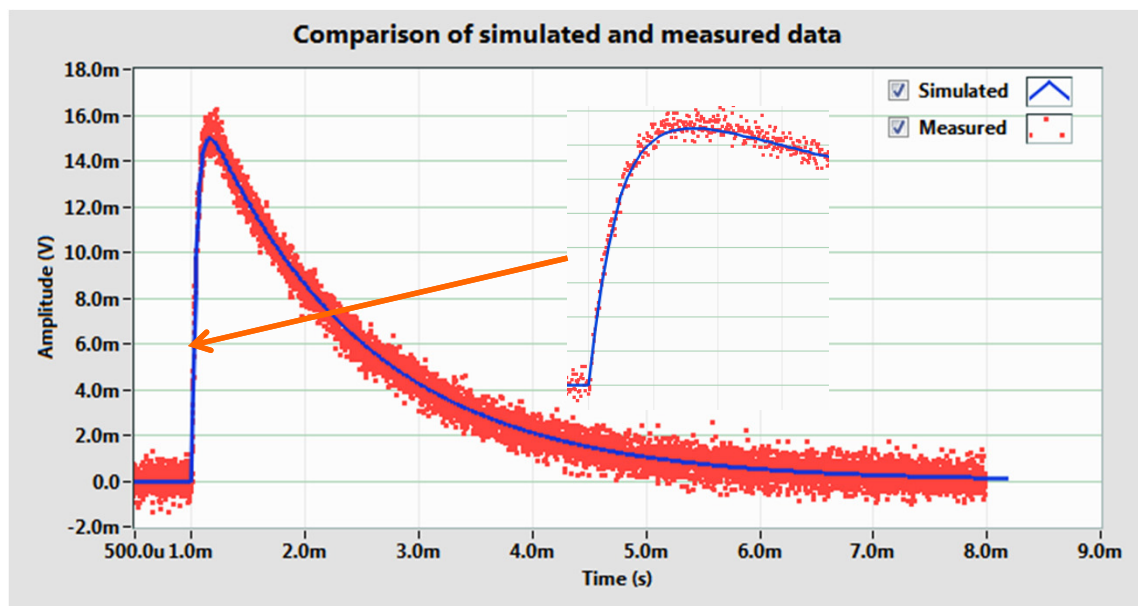

Comparison of simulated and measured signal

→ Very good match!

# Prototype cRIO-based data-acquisition

- cRIO system cost is about \$10k
- Runs RT OS
- EPICS integrated
- FPGA for timing

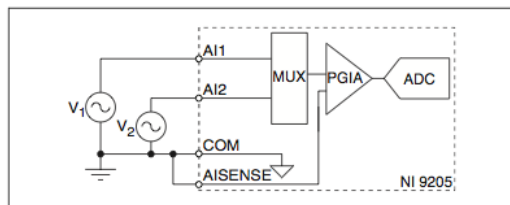
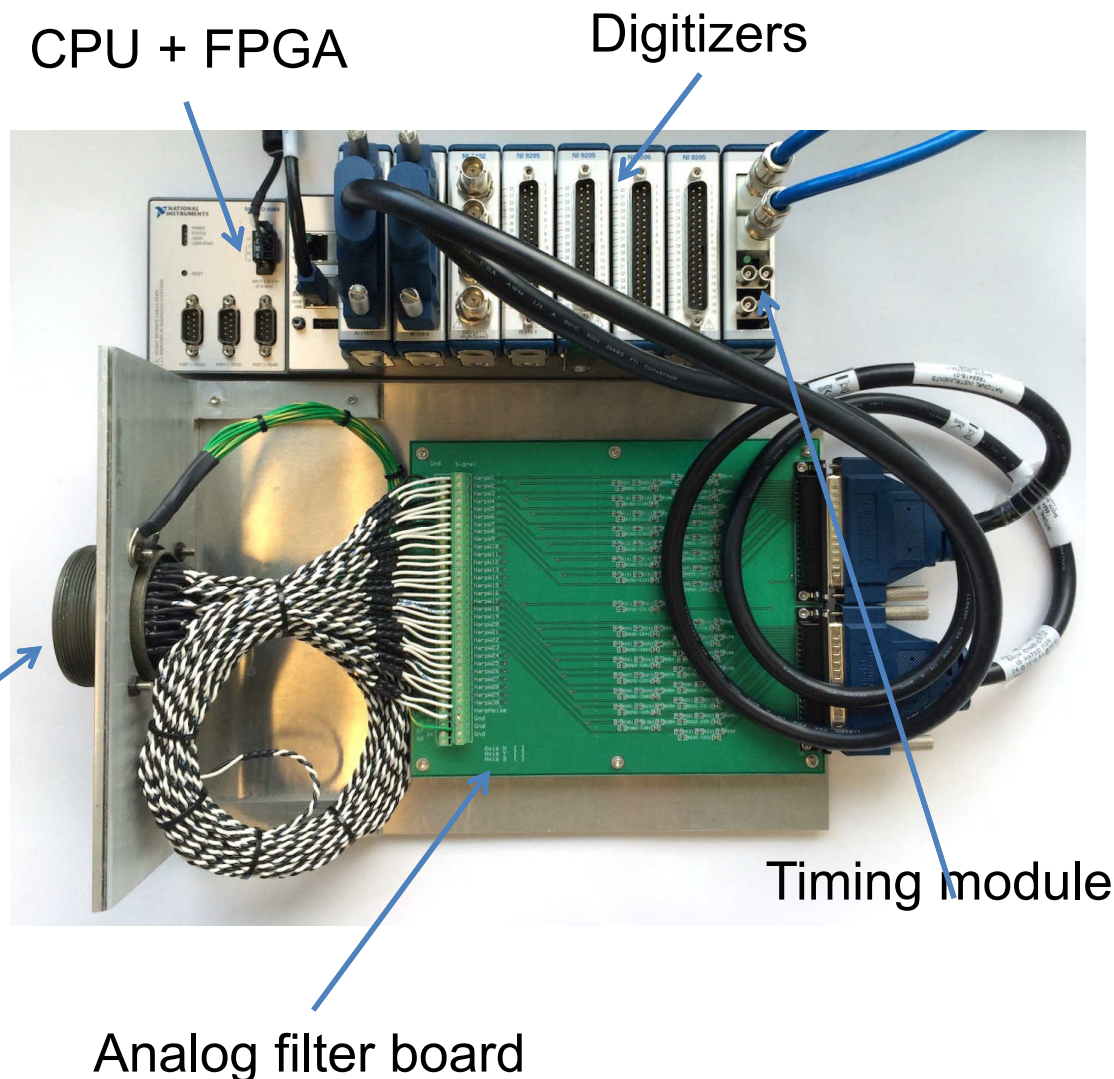

Figure 8. Connecting a Device to the NI 9205 Using NRSE Connections

In an NRSE connection configuration, the NI 9205 measures each input channel with respect to AI SENSE.



# Initial Results: First Test

- Diagonal beam profiles for different proton beam charges.

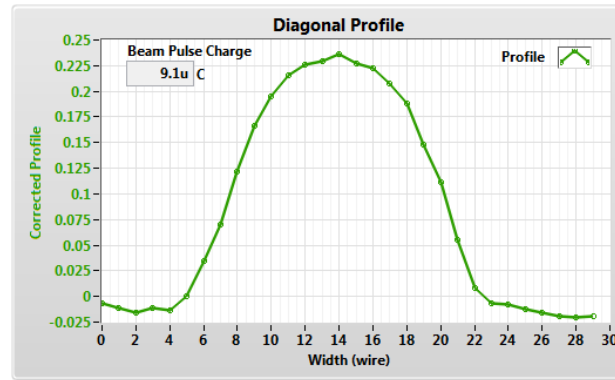

9.1  $\mu$ C

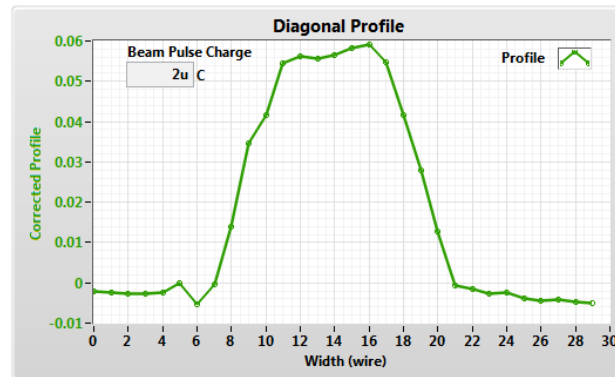

2.0  $\mu$ C

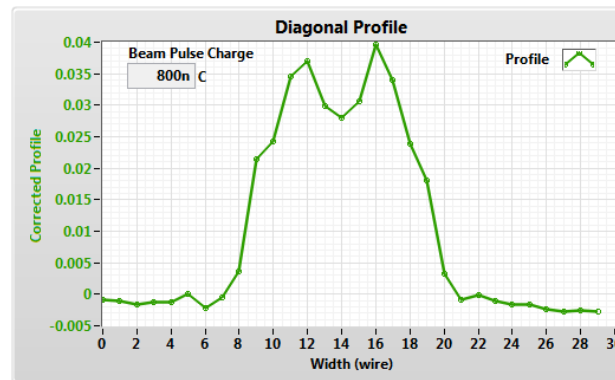

0.8  $\mu$ C

# Initial Results: Second Test

- Second study to get prototype system data and get profile data of existing system for direct comparison

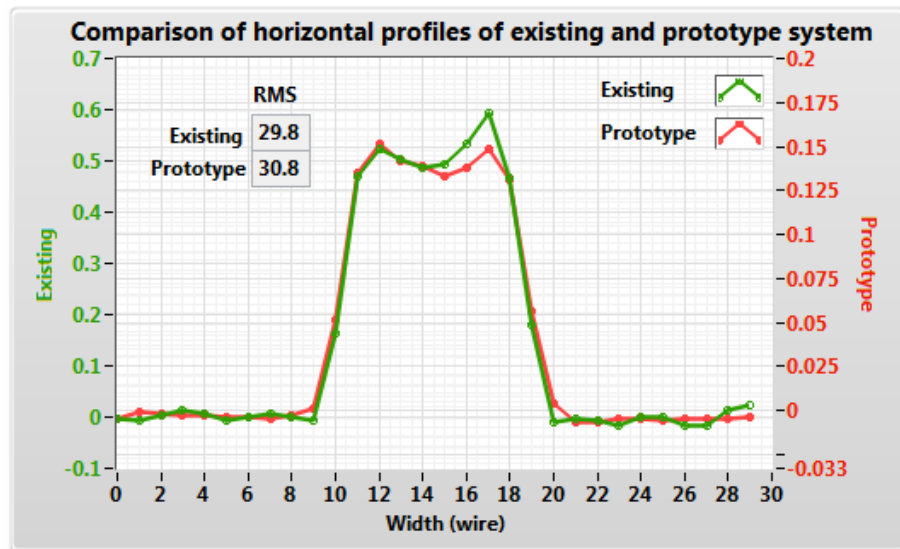

Horizontal Profile at 5  $\mu\text{C}$

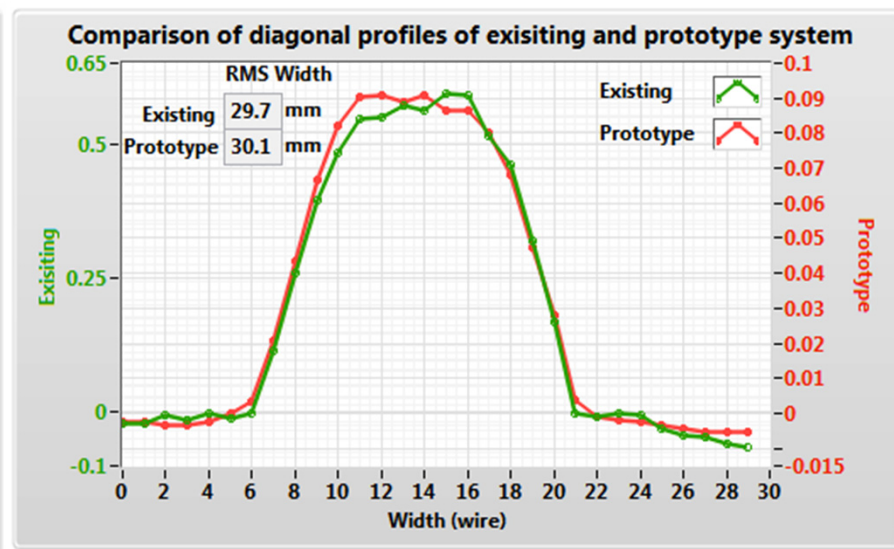

Diagonal Profile at 5  $\mu\text{C}$

→ RMS width of fitted function within 3% between existing and prototype system

# Initial results: Second Test

- Negative going trace is seen at high beam intensities but in the noise at lower intensities on both systems

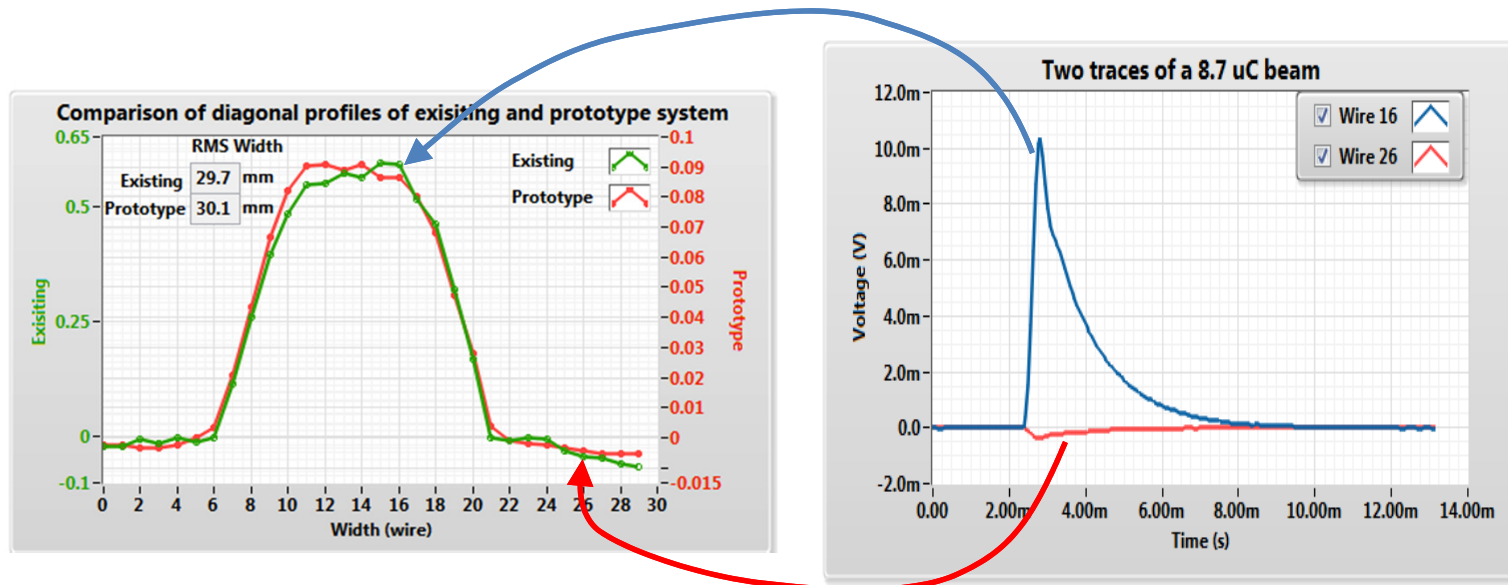

- Speculation is that bias voltage is not high enough to suppress electrons to migrate to nearby wires

# Initial results: Second Test

- Low intensity results: Need enough turns, typically  $\sim 20$ , to create wide enough beam for profile

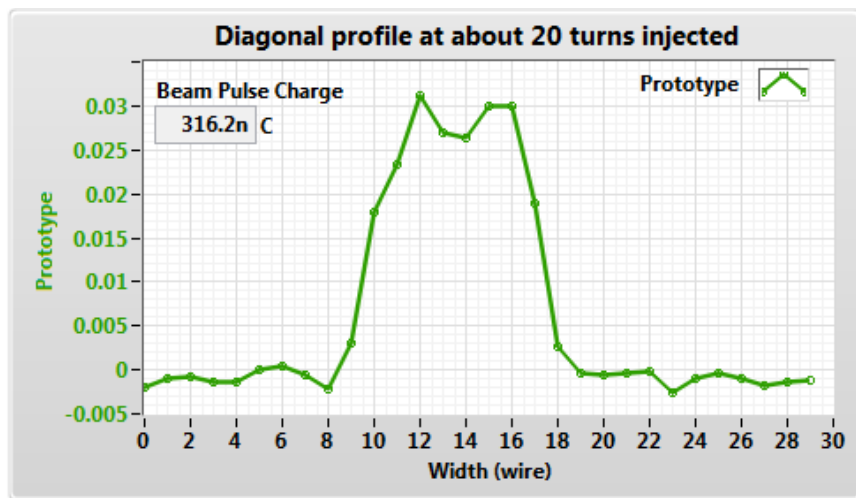
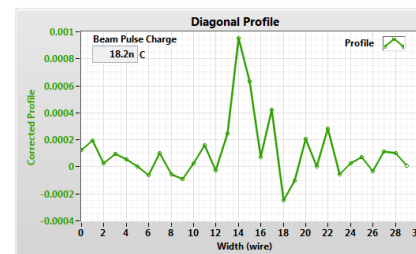

$\sim 20$  turns of beam at 316 nC

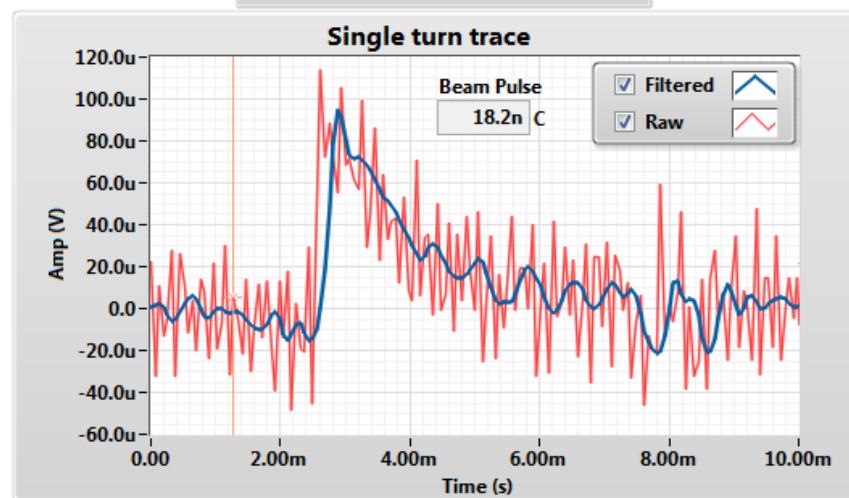

Trace of single beam pulse

→ Sensitive enough to see single pulse



# Discussion

- The prototype results are encouraging:
  - It can see single turn beam, well below the requirements, and it should easily see full beam without saturation
  - System can acquire at 60 Hz, so we can average profiles
  - The signal-to-noise can be further improved by switching to full differential mode, but this will require doubling the number of filters
- We must investigate negative going trace: modify bias supply but also compare profiles with wire scanners
- We plan to automate the uniformity scans and SEM coefficient measurement:
  - To improve these measurements
  - To see if the results change with exposure of the wires to the beam.

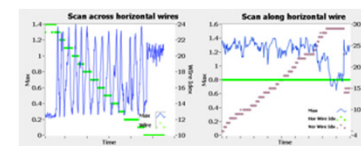
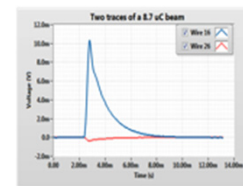
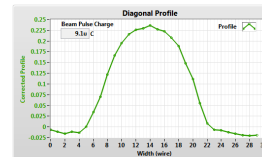

# Acknowledgements

The author wishes to thank in particular:

- Mike Plum for helping with the uniformity scan and calculating the model SEM value, and
- Syd Murray for his assistance with testing of prototype system and the implementation of the prototype analog board.

## REFERENCES

- [1] M. Holding et al., "Engineering The SNS RTBT/Target Interface For Remote Handling", PAC'05, Knoxville, TN, 2005, pp 2278-80.
- [2] M.A. Plum, "Wire scanner and harp signal levels in the SNS", SNS Tech Note 104050200-TD00230-R00, Dec 2001.
- [3] M.A. Plum, "SNS Harp Electronics Design", SNS Harp Workshop, March 13, 2003, ORNL, Oak Ridge, TN, USA.
- [4] W. Blokland, "Fitting RTBT Beam Profiles: the case for the Super-Gaussian", Internal talk at SNS, November 2, 2009
- [5] M.A. Plum, "Interceptive Beam Diagnostics -Signal Creation and Materials Interactions", BIW2004, AIP Conf. Proc. **732**, 23 (2004)