

TEN GAP MODEL OF A NEW ALVAREZ DTL CAVITY AT GSI

Anja Seibel, IAP University of Frankfurt, Germany

Xiaonan Du, Lars Groening, Oliver Kester, Sascha Mickat, GSI, Darmstadt, Germany

Abstract

In order to meet the challenges of the FAIR project at GSI requiring highest beam intensities an upgrade of the existing Universal Linear Accelerator (UNILAC) is planned. The 108 MHz cavities will be replaced by new rf-structures of the same frequency. Simulations are done to improve the rf-properties. The geometry of the drift tubes is to be changed to a smoother curvature to reach a homogeneous surface field distribution and higher shunt impedances. To check the necessity of cooling channels, simulations on the temperature distribution at the drift tubes and stems are conducted. A test bench for low power rf-measurements with a 10 gap aluminum model (scale 1:3) is under construction. The modular mechanical design of the model will allow probing experimentally a wide range of drift tube and stem geometries. With the bead pull method the electrical field distribution will be measured as well as the field stability with respect to parasitic modes. Additionally, appropriate locations along the cavity to place fixed and dynamic rf-frequency tuners will be determined.

As shown in Fig. 2, the existing HSI (high current injector) branch of the UNILAC consists of two ion source terminals, one RFQ, two IH cavities, a gas-stripper, and the poststripper with five Alvarez cavities and 10 single gap cavities. After the HSI the beam has an energy of 1.4 MeV/u. The operating frequency of the Alvarez DTL is 108.408 MHz accelerating the beam to the final energy of 11.4 MeV/u [3]. After almost 40 years in operation it is recommended to replace this section with an improved Alvarez DTL [4].

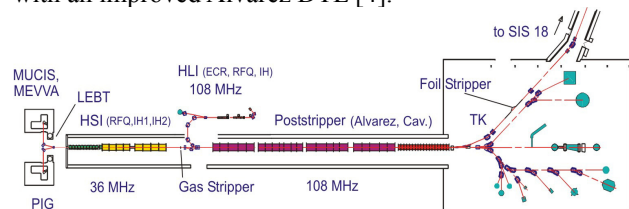

Figure 2: Existing UNILAC at GSI with the five Alvarez cavities working at 108.408 MHz [5].

DESIGN OF THE TEN GAP MODEL

A set of simulations has been performed using CST Microwave Studio [6] to improve the rf-properties of the existing Alvarez cavity [7]. Therefore a 1:3 scale ten gap model (Fig. 3) is simulated with a new design geometry inside. The frequency scales correspondingly to three times 108.408 MHz (= 325.224 MHz). To reach the exact frequency after fabrication, the tank is designed a bit larger in diameter, in accordance that the operating frequency is lower and can be shift up by tuners. The reasons for such procedure are small inaccuracies in fabrication which influence the frequency. The model design parameters are listed in Tab. 1.

The ten gap model with nine full and two half drift tubes at the end plate allows to vary the angle between the stems. With the rotating stem geometry the frequency of the TM011 mode (Fig. 4) can be pushed away in the simulations more than 5 MHz from the operating TM010 mode for the existing Alvarez 3 tank [7]. The stem configuration of each drift tube is used to damp parasitic modes and thus increase the field stability. In addition, the drift tube cabs are exchangeable to compare different drift tube geometries.

The goal is to optimize the rf-design geometry with respect to the field distribution stability. Therefore the above mentioned 10 gap aluminium model is under construction, to verify the simulated results using the bead pull method. The calculated electric field profile along the beam axis (Fig. 5) shows a flatness of better than 3 %.

THE FAIR PROJECT

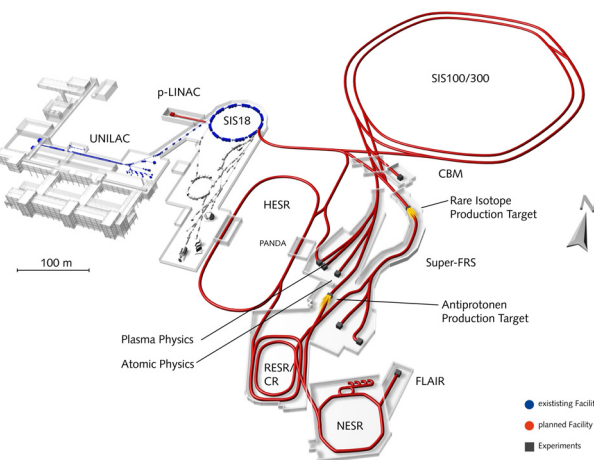

Figure 1: The FAIR facility in the full version [1].

The FAIR project (Fig. 1) will be a new international particle accelerator facility for antiprotons and heavy ions which is currently under construction [1]. This project will provide knowledge of still unknown subatomic components of matter in the Universe. In parallel the existing GSI facility is upgraded together with a new proton linear accelerator and will serve as pre-accelerator and injector for the new heavy ion synchrotron SIS100. The SIS100 beams are delivered to a complex of storage rings [2] and experimental stations reaching energies and intensities as required for FAIR [1].

Content from this work may be used under the terms of the CC BY 3.0 licence (© 2015). Any distribution of this work must maintain attribution to the author(s), title of the work, publisher, and DOI.

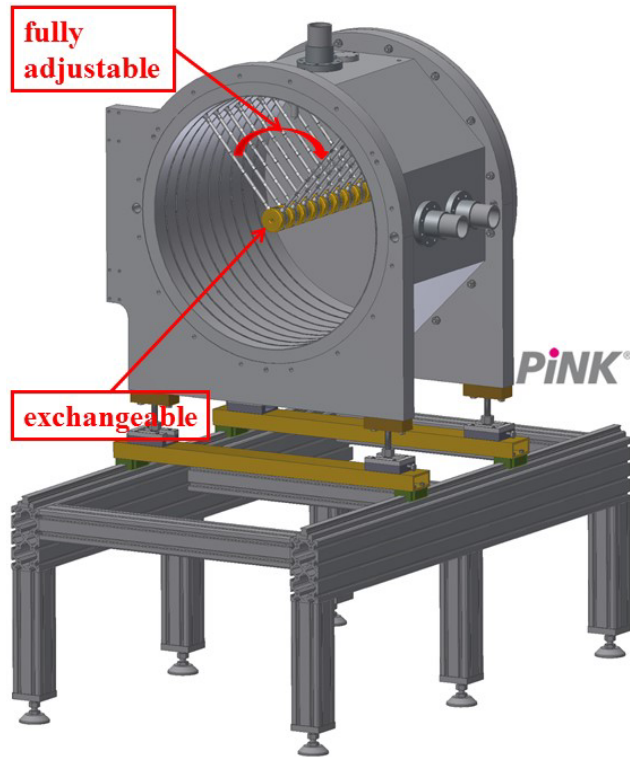

Figure 3: Ten gap Alvarez model with the variable stem geometry for low power rf-measurements [8].

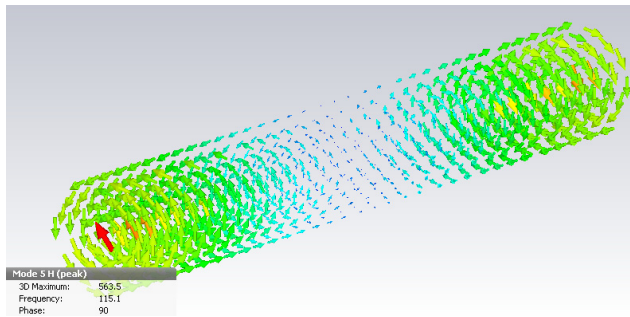

Figure 4: Magnetic field distribution of the parasitic mode TM011 [6, 7].

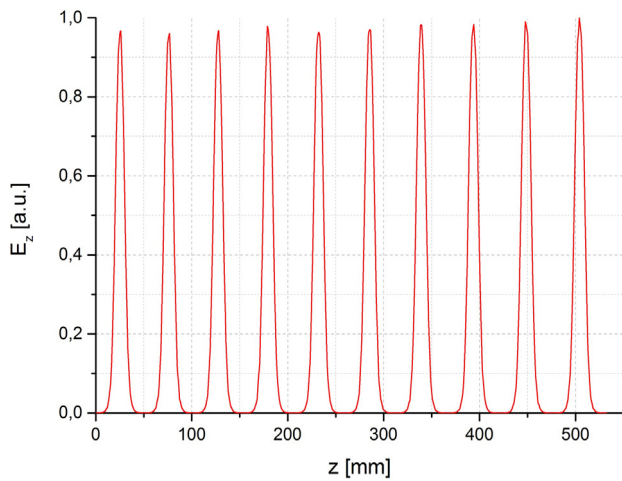

Figure 5: Calculated axial electrical field distribution.

The geometry of the drift tubes (Fig. 6) is changed with respect to the existing design to improve the ratio of shunt impedance to maximum surface field. This geometry allows a more homogeneous surface field distribution (Fig. 7) as well [7].

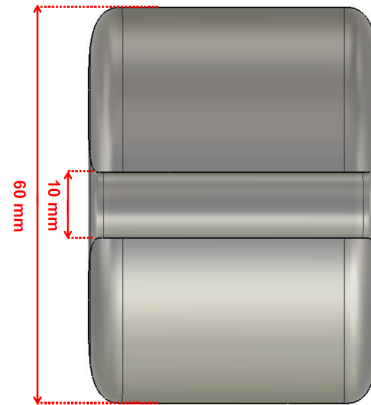

Figure 6: Design of the new drift tube geometry for the 1:3 model. Inner diameter: 10 mm and outer diameter: 60 mm [6].

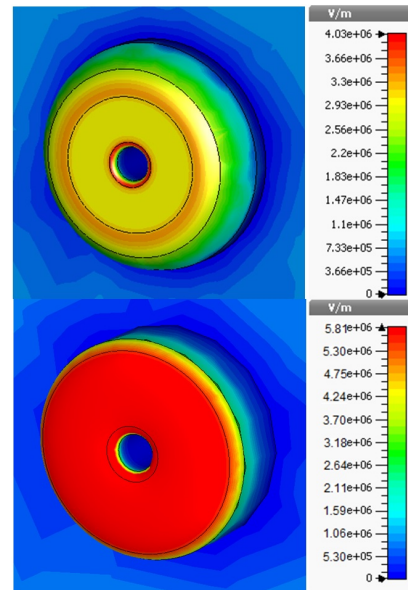

Figure 7: Old drift tube design (above) with the absolute electric field distribution. New drift tube design (below) with a homogeneous field distribution [6, 7].

Table 1: Design Parameters (1:3 – Model)

Parameter	Unit	Value
# of Gaps	-	10
Tank length	mm	526
Tank diameter	mm	634.5
Aperture diameter	mm	10
Frequency	MHz	325.224
Q-Factor		50000

Content from this work may be used under the terms of the CC BY 3.0 licence (© 2015). Any distribution of this work must maintain attribution to the author(s), title of the work, publisher, and DOI.

The adjustability of the stem length is realised by a right-left-hand thread, while the angle variation of the stems is provided by dovetail grooves in the tank and the drift tubes. The resonance frequency of the cavity is reduced by 500 kHz compared to a cavity without grooves.

TUNING

To match the operation frequency tuners are needed, therefore three different positions for the tuners along the tank are investigated (Fig. 8). The inductive tuners are cylindrical with a diameter of 60 mm. The frequency shift is 0.4 MHz per tuner per 100 mm plug-in depth (Fig. 9). The field distribution is independent of the tuner position for all three tuners and the frequency shift is the same of each tuner.

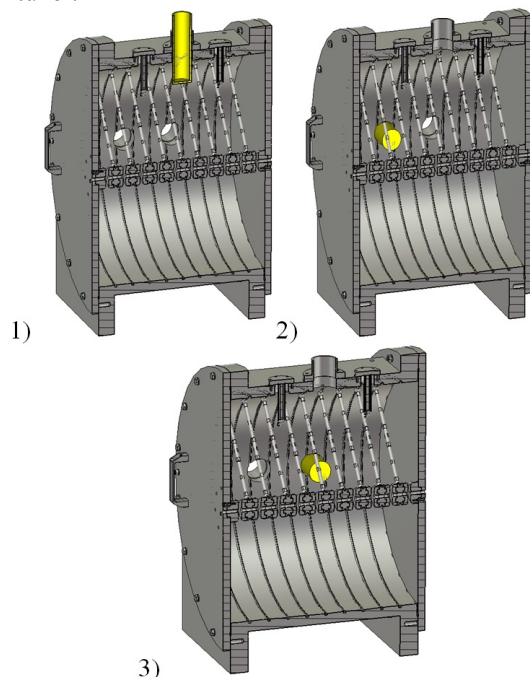

Figure 8: Three tuner positions to test fixed and dynamic tuners [6].

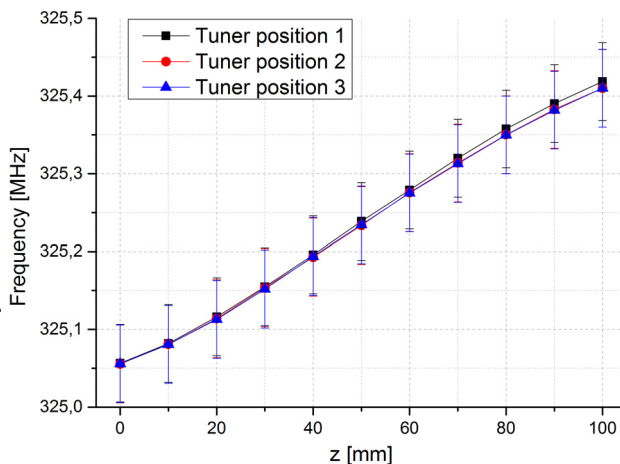

Figure 9: Simulated shift of the resonance frequency for the three tuner positions varying the penetration depth.

THERMAL SIMULATIONS

In the future the UNILAC will be operated with 2 ms rf-pulse duration and 10 Hz repetition rate which corresponds to a duty cycle of 0.02. Simulations on the temperature distribution (Fig. 10) at the drift tubes and stems are performed (for a real sized ten gap tank). First the surface current distribution is simulated to identify the areas with the most significant power flux. The highest current occurs in the area of the stems, which therefore needs to be cooled most.

The drift tubes and stems have cooling channels around their whole body. For the tank 12 cooling channels in parallel to the beam axis are sufficient. The water temperature is set constant to the room temperature of 293 K. The highest temperature read in simulation occurs in the area of the end plates which are not cooled yet. The simulated temperature rise is just 3.5 K, however it is planned to cool the end plates as well.

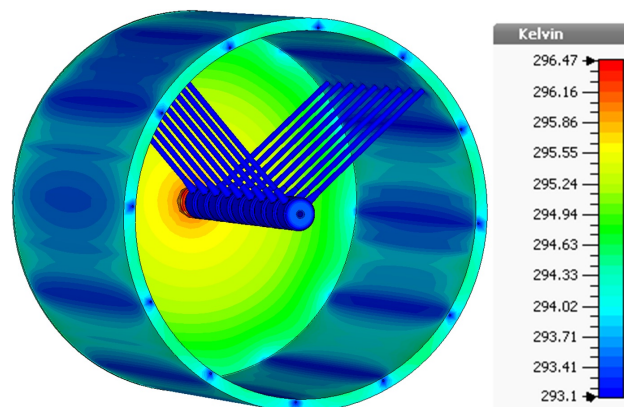

Figure 10: Temperature distribution with water cooling [6].

OUTLOOK

Fabrication of the 10 gap aluminium prototype (without cooling channels and copper plating) has already started at PINK GmbH Vakuumtechnik. The delivery of the model is expected in June 2015. Electric field distribution measurements using the bead pull method are planned at the p-linac test bench at GSI. The low power rf-model can be extended by additional tank segments.

REFERENCES

- [1] www.fair-center.eu
- [2] O. Kester et al., IPAC15 proceedings, TUBB2.
- [3] L. Groening et al., IPAC15 proceedings, TUXB2.
- [4] S. Mickat et al., internal report 2014.
- [5] www.gsi.de
- [6] www.cst.com
- [7] X. Du et al., IPAC15 proceedings, WEPMA017.
- [8] www.autodesk.de