

EXTRACTING A HIGH CURRENT LONG PULSE H⁻ BEAM FOR FETS

D. Faircloth, M. Perkins, S. Lawrie, C. Gabor, M. Cannon, STFC/RAL/ISIS, Chilton, Oxfordshire, OX11 0QX, UK

Abstract

The Front End Test Stand (FETS) at the Rutherford Appleton Laboratory (RAL) requires a 60 mA 2 ms 50 Hz H⁻ beam. A Penning Surface Plasma Source (SPS) is used to produce the beam. This paper gives the latest results obtained using a new 25 kV long pulse extraction power supply designed and built at RAL. Power supply performance, beam current and emittance are detailed.

INTRODUCTION TO FETS

High power short-pulse proton drivers are required for a wide range of applications including neutron spallation sources, neutrino factories, muon colliders, ADSRs and nuclear waste transmutation. In order to generate high power beams, proton drivers typically require multi-turn charge-exchange injection of H⁻ ions into an accumulator ring. The overall deliverable power and quality of the beam is largely determined by the initial accelerating stage of the machine: the 'Front End'. Creating a front end to meet the demands of modern proton drivers is an ongoing challenge in accelerator technology.

For hands-on maintenance of high power proton drivers, the beam-loss-induced radio-activation of components must be kept to a minimum. One of the major sources of beam loss is the trapping of particles in the ring RF buckets. By pre-chopping the H⁻ beam in the linac, trapping losses are considerably reduced. Chopping should be performed at low energy, in the front end, to ease the dumping of up to 40% of the beam. Chopping should also be as quick as possible so there are no partially chopped bunches leaving the linac. A sufficiently quick 'perfect' chopper has yet to be demonstrated anywhere in the world.

FETS is based in building R8 at RAL. It is a collaboration between ISIS, ASTeC, Imperial College, University of Warwick, University College London and Royal Holloway. This project will design, build and test the first stages necessary to produce a very high quality, perfectly chopped H⁻ ion beam as required for high power proton drivers. The beam parameters are 3 MeV energy and 60 mA beam current at 50 Hz repetition rate and up to 2 ms pulse duration.

FETS ION SOURCE AND LEBT

FETS uses a Penning Surface Plasma Source (SPS) [1] (Fig. 1) and a 3 solenoid Low Energy Beam Transport (LEBT) [2] which will transfer beam into the 3 MeV Radio Frequency Quadrupole (RFQ). The results presented in this paper use the setup shown in Fig. 2 with a diagnostic vessel where the RFQ will be.

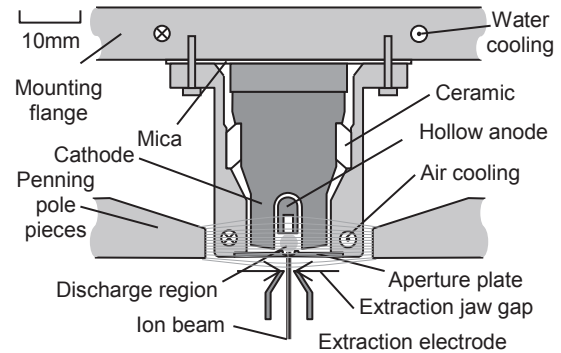

Figure 1: FETS Penning SPS schematic.

EXTRACTION CHALLENGE

Ion source extraction systems are a challenging load for power supplies. Not only must the supply deliver regulated voltages for a wide range of currents it must also cope with breakdowns. Caesiated negative surface plasma Penning sources [1] pose a particular challenge because they have high extraction current densities, large co-extracted electron currents and caesium coated electrodes. All of which encourage breakdowns. The power supply must be able to keep working reliably with multiple breakdowns that inevitably occur during the electrode conditioning process.

To overcome these challenges an extraction voltage power supply has been developed at RAL [3]. The power supply is based on a design that has reliably extracted beam for ISIS operations for almost 20 years. It consists of a 1μF reservoir capacitor that is switched by an Amperex 8960 tetrode and regulated using an analogue control system.

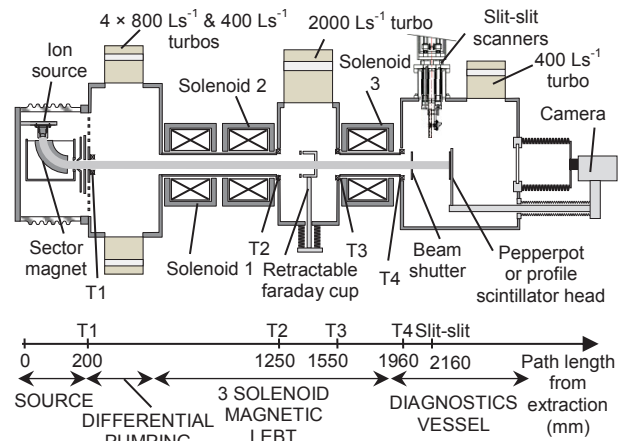

Figure 2: The FETS ion source and LEBT schematic.

MAXIMUM EXTRACTION VOLTAGE POWER SUPPLY PERFORMANCE

The extraction power supply is tested into a 215 kΩ resistive load to confirm the maximum voltage output. Figure 3 shows the output voltage pulse shape at 50 Hz, 2ms duty. Figure 4 shows the corresponding current pulses. The maximum voltage obtained is 28 kV.

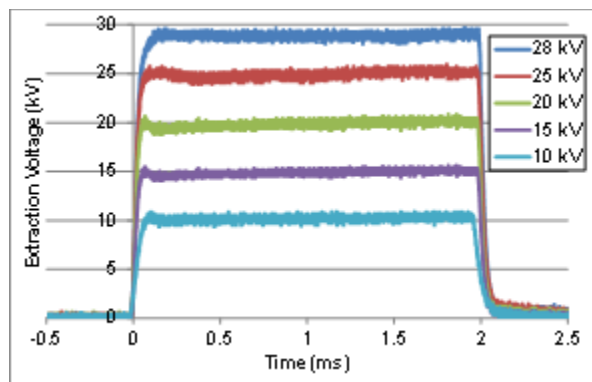

Figure 3: Extraction power supply voltages at a 2 ms, 50 Hz duty cycle into a 215 kΩ resistive load.

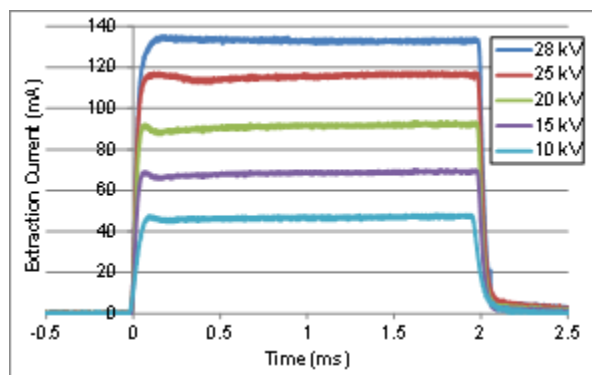

Figure 4: Extraction power supply currents, 2 ms, 50 Hz duty cycle into a 215 kΩ resistive load.

VARY EXTRACTION ELECTRODE JAW GAP

Two different extraction electrode jaw gaps (Fig. 1) are tested: 2.1 mm and 1.1 mm. Beam currents are measured using toroids and the emittances measured using X and Y slit-slit scanners, the results are shown in Figs. 5 and 6 respectively. The positions of the toroids and slit-slit scanners are shown in Fig. 2. The 3 solenoid currents are set as follows: S1 = 220 A, S2 = 80 A, S3 = 220 A. The extraction voltage is set to 21 kV. The beam energy is 65 keV. The normalised rms emittances are approximately 0.6 πmm.mRads.

Higher currents are extracted and transported with the narrow jaw setting and the focal length is shorter, which provides the best match into the RFQ.

Figure 7 and 8 show the electric fields and particle trajectories calculated with IBSIMU [4]. The equipotential lines do not penetrate as far with the smaller jaw gap. This causes less defocusing of the beam.

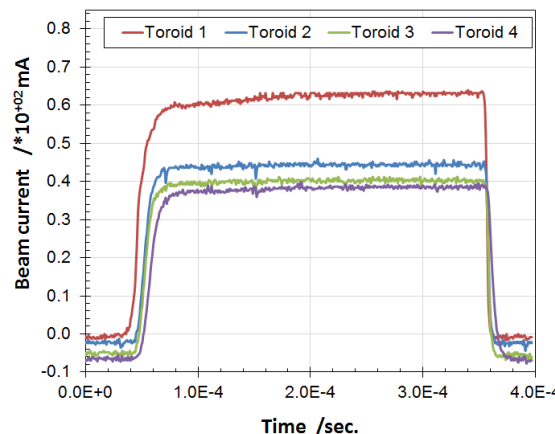
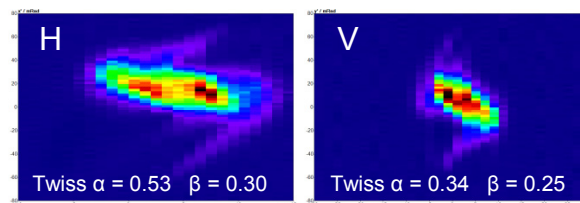

Figure 5: Emittance and beam currents for a 2.1 mm wide extraction jaw gap.

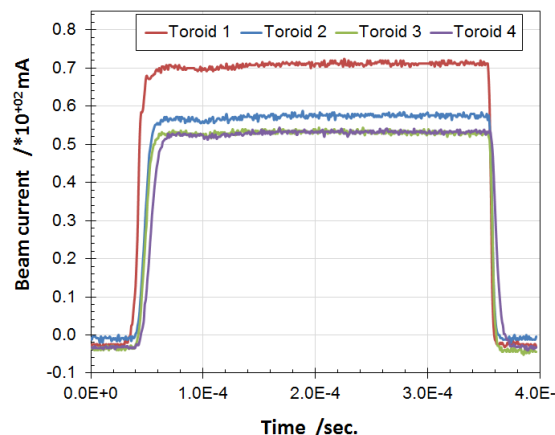
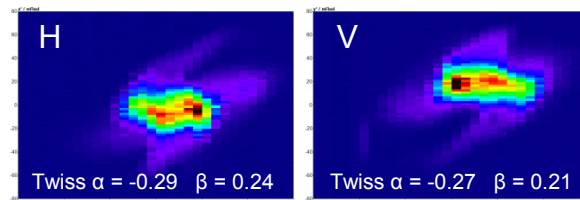

Figure 6: Emittance and beam currents for a 1.1 mm wide extraction jaw gap.

MAXIMUM SOURCE PERFORMANCE

Figure 9 shows the beam currents with the solenoids off. The maximum transmission is achieved for a 21 kV extraction voltage. Beyond 21 kV the beam becomes too divergent and the transmission drops.

If the beam current at T1 is optimised by varying the sector magnet, the maximum current extractable from the source can be found. Figure 10 shows that for at 25 kV extraction voltage almost 90 mA of H- can be extracted.

Content from this work may be used under the terms of the CC BY 3.0 licence (© 2014). Any distribution of this work must maintain attribution to the author(s), title of the work, publisher, and DOI.

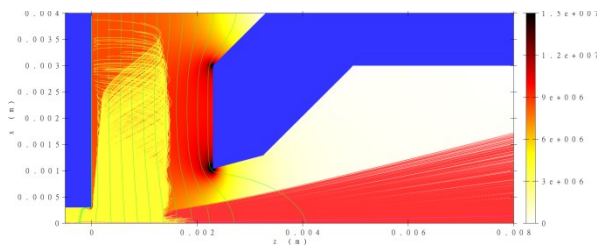

Figure 7: The electric field strength, equipotential field lines (green), H^- ion trajectories (red), and electron trajectories (yellow) for a 2.1 mm extraction electrode jaw gap.

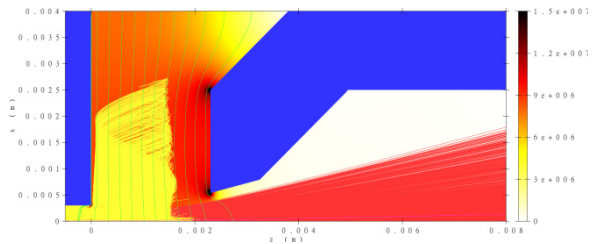

Figure 8: The electric field strength, equipotential field lines (green), H^- ion trajectories (red), and electron trajectories (yellow) for a 1.1 mm extraction electrode jaw gap.

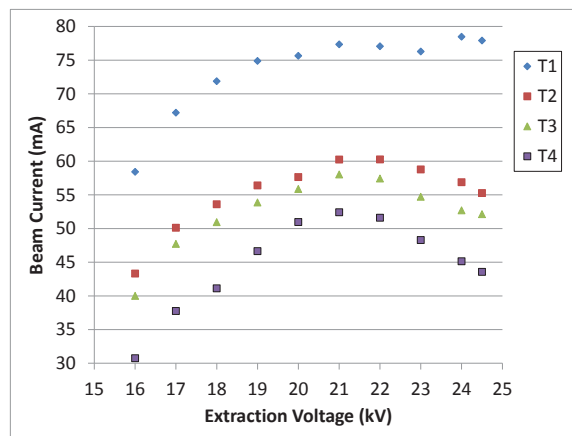

Figure 9: H^- ion currents measured at the 4 toroids for different extraction electrodes.

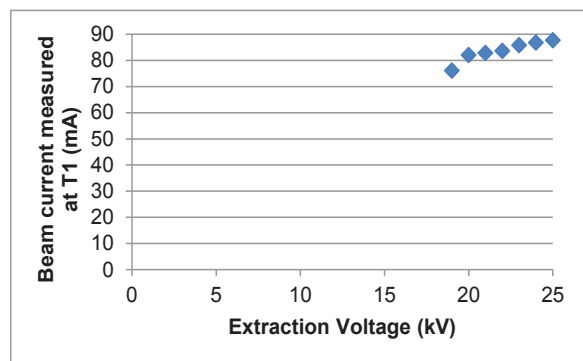

Figure 10: Peak H^- ion currents measured at T1 after optimising the sector magnet current.

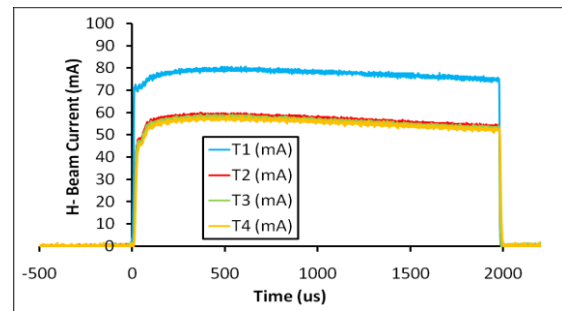

Figure 11: H^- ion currents measured at the 4 toroids for a 2 ms 25 Hz duty cycle.

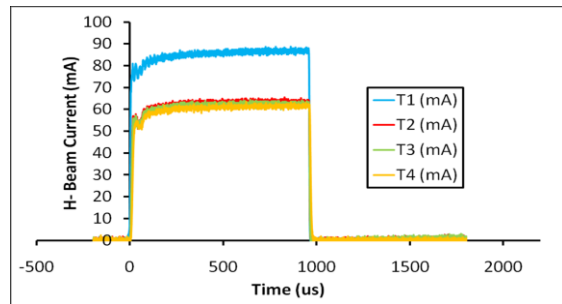

Figure 12: H^- ion currents measured at the 4 toroids for a 1 ms 50 Hz duty cycle.

SUMMARY AND OUTLOOK

The extraction power supply has demonstrated that it is capable of reliably meeting the 2 ms, 50 Hz duty cycle requirements.

The source is capable of meeting all the FETS beam requirements, but not simultaneously. Figure 11 shows a 2 ms pulse at 25 Hz rep rate. Figure 12 shows a 1 ms pulse at a 50 Hz rep rate. For 2 ms pulse lengths at 50 Hz there is too much droop on the beam current. A dedicated ion source test stand has been built [5] that will allow new extraction configurations and scaled sources to be developed that are capable of meeting the full FETS beam requirements. In the short term, the existing source is capable of providing beam for RFQ and chopper commissioning.

REFERENCES

- [1] D.C. Faircloth et al., “The Front End Test Stand high performance H^- ion source at Rutherford Appleton Laboratory”, Review of Scientific Instruments, Volume 81, Issue 2, (2010).
- [2] J. Back et al., “Performance of the Low Energy Beam Transport at The RAL Front End Test Stand”, THPME073, these proceedings, IPAC’14, Dresden, Germany (2014).
- [3] D.C. Faircloth et al., “A New Long Pulse High Voltage Extraction Power Supply for FETS”, MOPEA064, IPAC’13, Shanghai, China (2013).
- [4] <http://ibsimu.sourceforge.net/>
- [5] S.R. Lawrie et al, “Installing the VESPA H^- Ion Source Test Stand at RAL”, MOPRI015, these proceedings, IPAC’14, Dresden, Germany (2014).