



**GALAXIE: GV-per-meter AcceLerator And
X-ray-source Integrated Experiment**

A Dielectric Laser Accelerator-Based, GV/m All-Electromagnetic FEL

James Rosenzweig

UCLA Dept. of Physics and Astronomy

IPAC 2013, Shanghai, China

May 14, 2013



The GALAXIE Collaboration

- UCLA Dept. of Physics and Astronomy
 - Miao, Musumeci, Putterman, Rosenzweig
- Stanford Linear Accelerator Center
 - Tantawi, Yakimenko (late of BNL)
- Penn State University
 - Jovanovic
- RadiaBeam Technologies
 - Murokh, Boucher
- UCLA Electrical Engineering
 - Candler
- Brookhaven National Laboratory
 - Pogorelsky

Collaborations on micro-undulators/MEMS beam optics with Candler group (UCLA) and Arnold group (Florida); cathode physics with SRI

GALAXIE: An *Integrated* Table-top X-ray FEL

GALAXIE: GV-per-meter AcceLerator And X-ray-source Integrated Experiment

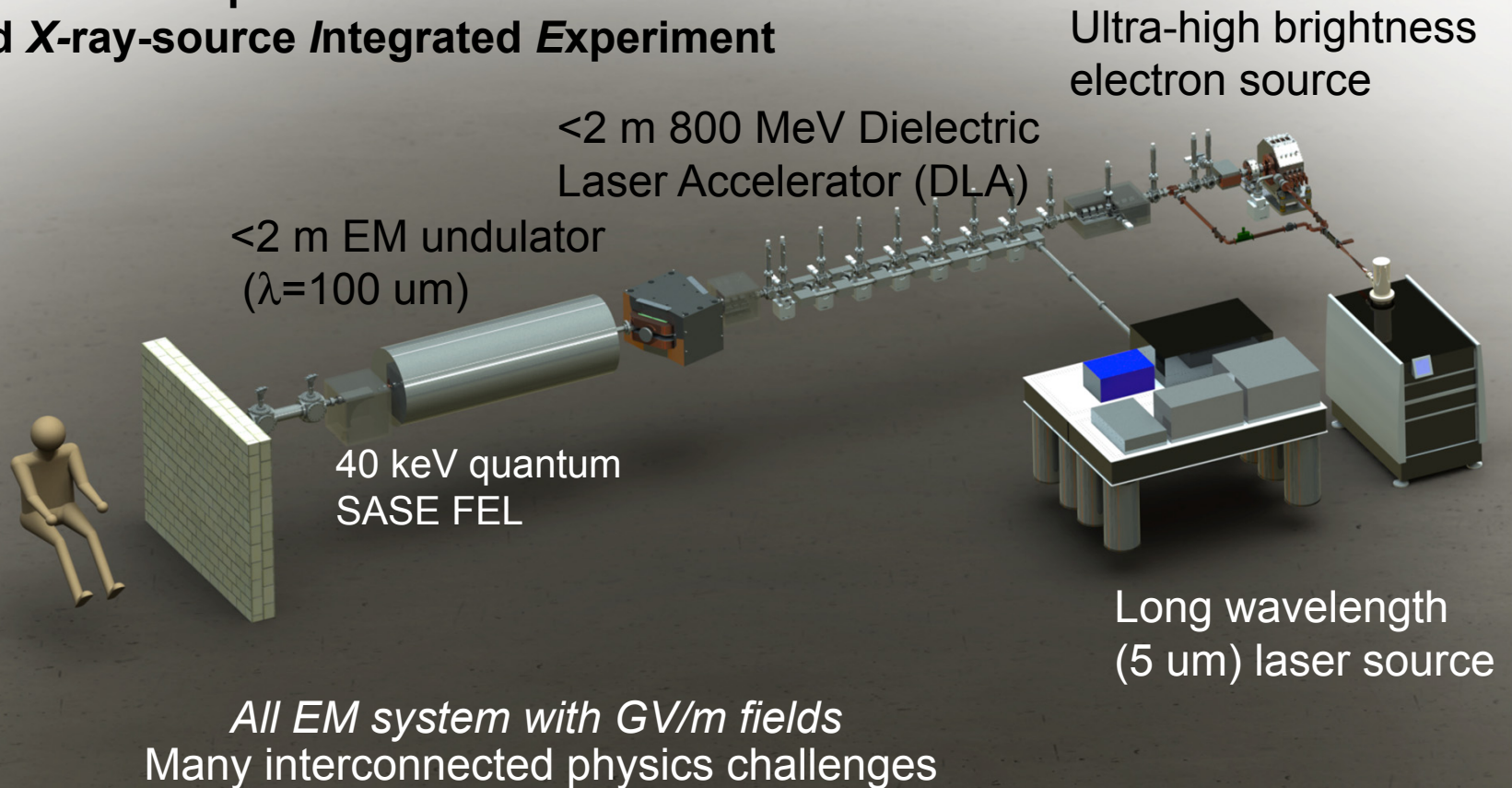

GALAXIE: A 5th Generation Light Source

Physics & Applications of High Brightness Electron Beams: Towards a 5th Generation Light Source



ICFA sponsored workshop
San Juan, Puerto Rico,
March 25-28, 2013

5th Generation: Marriage of new high gradient accelerators and light sources; burgeoning field with intense activity. GALAXIE is a key example (of many), within ambitious DARPA program



High brightness electrons beget high brightness photons

- FEL: 3-wave interaction instability

- Growth rate depends on e- beam $B_e \equiv \frac{2I}{\epsilon_n^2}$ *brightness*

$$L_{g1D} = \frac{\lambda_u}{4\pi\sqrt{3}\rho_{1D}} \quad \rho_{1D} = \left[\frac{JJ(K_{rms})K_{rms}k_p}{4k_u} \right]^{2/3} \propto B_e^{1/3}$$

- High I , small ϵ : dense lasing medium

$$E_{rad} \propto \exp(z/L_g); L_g \propto B_e^{-1/3}$$

- +8 orders of magnitude photon brightness: fs, *coherent* X-rays

- Revolution in imaging

- X-ray FEL needs high energy, very high quality electron beams

- Energy mitigated by short λ_u

$$\lambda \approx \lambda_u / 2\gamma^2$$

- Compact FEL possible, w/new accelerator

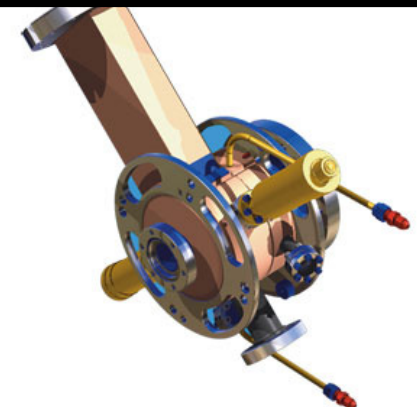
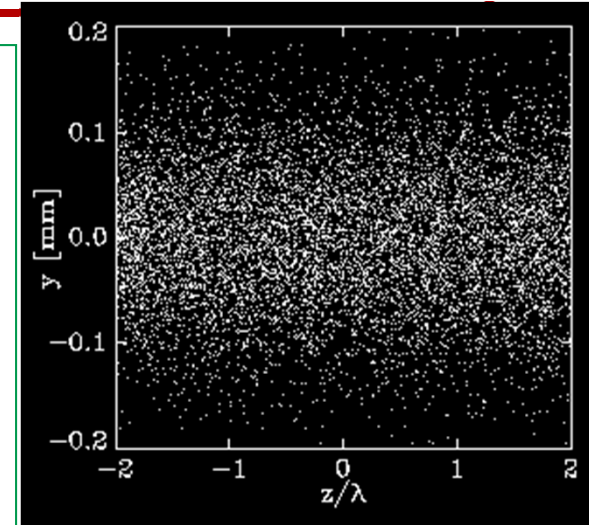

$$B_e = 2 \times 10^{14} \text{ A/m}^2$$



High brightness electrons beget high brightness photons

- FEL: 3-wave interaction instability
- Growth rate depends on e- beam $B_e \equiv \frac{2I}{\epsilon_n^2}$ *brightness*

$$L_{g,1D} = \frac{\lambda_u}{4\pi\sqrt{3}\rho_{1D}} \quad \rho_{1D} = \left[\frac{JJ(K_{rms})K_{rms}k_p}{4k_u} \right]^{2/3} \propto B_e^{1/3}$$

- High I , small ϵ : dense lasing medium

$$E_{rad} \propto \exp(z/L_g); L_g \propto B_e^{-1/3}$$

- +8 orders of magnitude photon brightness: fs, *coherent* X-rays
 - Revolution in imaging
- X-ray FEL needs high energy, very high quality electron beams
 - Energy mitigated by short λ_u
 - Compact FEL possible, w/new accelerator

$$\lambda \approx \lambda_u / 2\gamma^2$$

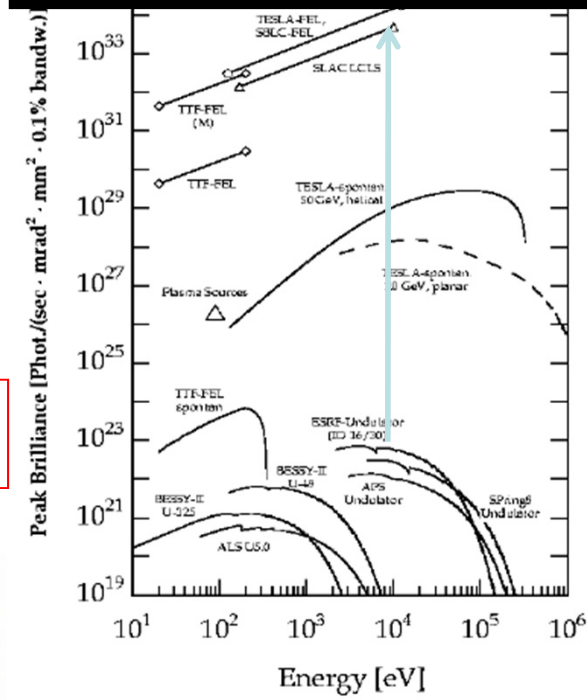
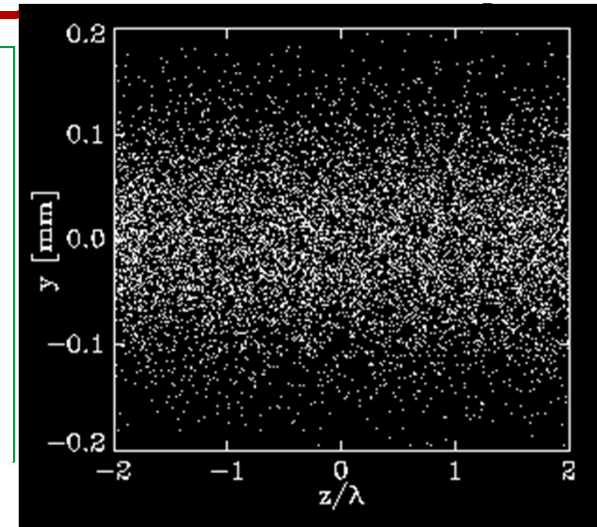

Glance at GALAXIE parameters

GALAXIE nominal design parameter list.

Parameter	Symbol	Value
Injection Energy	U_i	3-6 MeV
Normalized Emittances (split)	ϵ_x, ϵ_y	$2 \times 10^{-7}, 2 \times 10^{-9}$ m-rad
Normalized Emittances (round)	$\epsilon_x = \epsilon_y$	2×10^{-8} m-rad
Injection current (unbunched)	I_{ave}	1 A
Peak current (bunched)	I_p	300 A
Nominal acceleration field	E_{acc}	1 GV/m
Accelerating laser wavelength	λ	5 μm
FEL Operational Energy	U_f	720 MeV
FEL EM undulator wavelength	λ_u	100 μm
FEL undulator strength parameter	K	0.11
FEL Pierce parameter (3D)	ρ_{3D}	5×10^{-5}
FEL Gain Length	$L_{g,3D}$	9.3 cm
FEL Saturation Length	L_{sat}	1.8 m

Injector parameters set by FEL *and* accelerator



Choice of DLA wavelength

Why longer λ ? Structure/dynamics

- Avoid aperture limitations
 - Vertical ε @ 1E-9 m-rad for 5 μm case; 3E-11 m @ 0.8 μm !
 - Strong 2nd order focusing still needed
- More stable longitudinal acceleration — enlarged “buckets” $\sim \lambda$
 - Complex dynamics from focusing harmonic
 - Uses *adiabatic compression* in acceleration
- Mitigate structure (GV/m) breakdown
 - Small quantum energy
 - Optimize at \sim ps pulse length
- Breakdown thresholds unknown ($>$ GV/m)
 - *Material investigations performed*

Laser pulses
180 degrees
out of phase

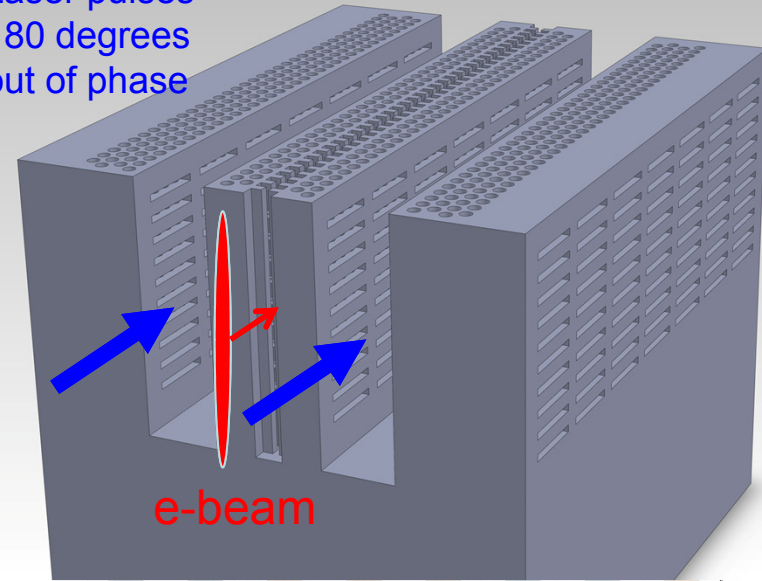

Biharmonic \sim 2D structure

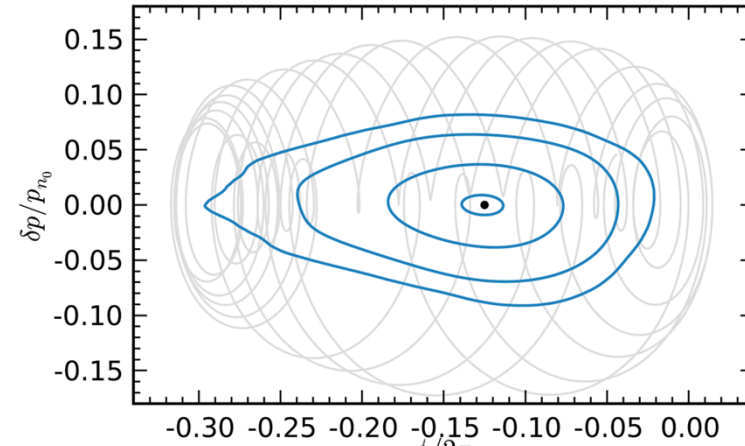

Longitudinal phase space



Choice of DLA wavelength

Why longer λ ? Structure/dynamics

- Avoid aperture limitations
 - Vertical ε @ 1E-9 m-rad for 5 μm case; 3E-11 m @ 0.8 μm !
 - Strong 2nd order focusing still needed
- More stable longitudinal acceleration — enlarged “buckets” $\sim \lambda$
 - Complex dynamics from focusing harmonic
 - Uses *adiabatic compression* in acceleration
- Mitigate structure (GV/m) breakdown
 - Small quantum energy
 - Optimize at $\sim\text{ps}$ pulse length
- Breakdown thresholds unknown ($>\text{GV/m}$)
 - *Material investigations performed*

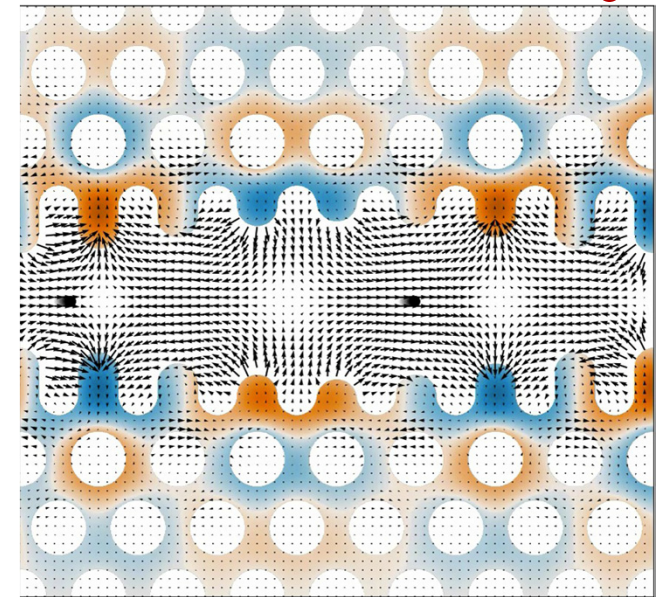

Biharmonic $\sim 2\text{D}$ structure

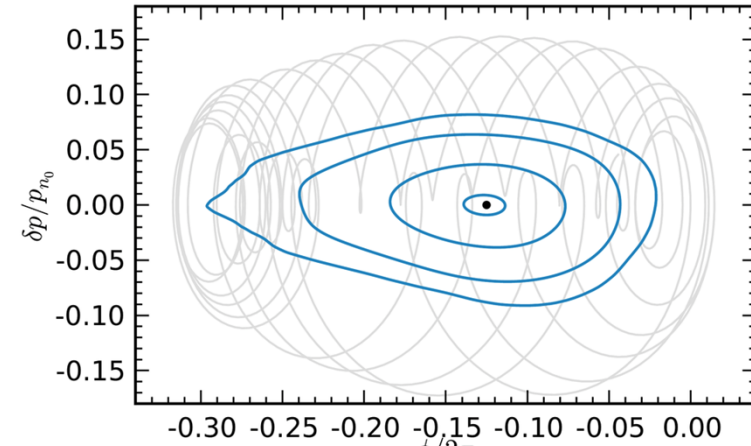

Longitudinal phase space



Ultra-high Brightness Electron Source

- DLA 3D stability requires injection >3 MeV
- Very high gradient (~150-200 MeV/m) S-band or X-band RF gun
 - Synergistic with standard FEL injectors
 - *No need to improve cathode “temperature”*; small spot possible!
- Magnetize cathode to obtain asymmetric emittances
 - skew quad splitter

Beam post-RF gun is angular momentum (L) dominated

150-200 MV/m
HB photogun

B_z at cathode gives coupling:
– L : angular momentum

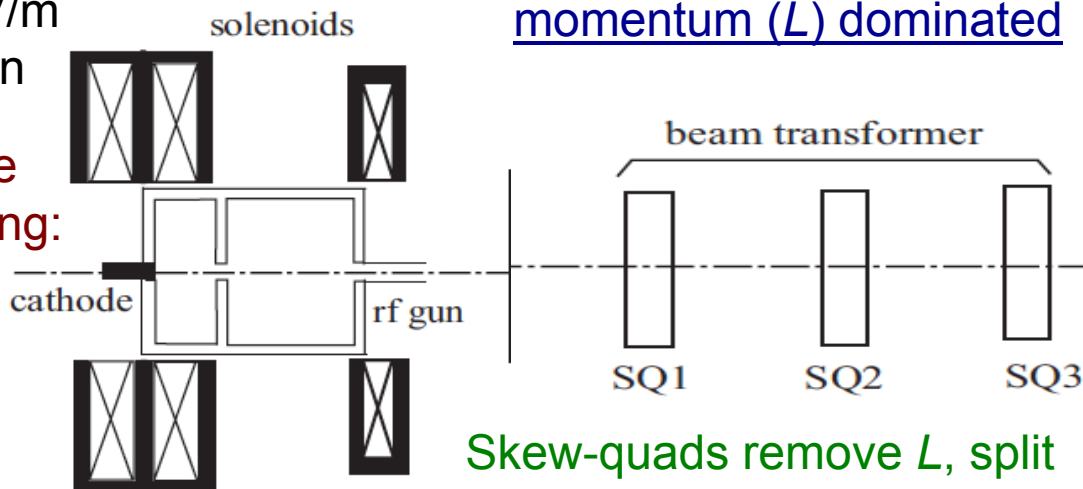

$$\begin{cases} \varepsilon_+ = \varepsilon + L \\ \varepsilon_- = \varepsilon - L \end{cases}$$

Skew-quads remove L , split emittances in x and y

$$\varepsilon_+ \approx 10^{-7} \text{ m-rad}$$

$$\varepsilon_- \approx 10^{-9} \text{ m-rad}$$



Source: simulated performance

- Dynamics include space-charge ($Q=1$ pC)
 - Emittance compensation w/angular momentum

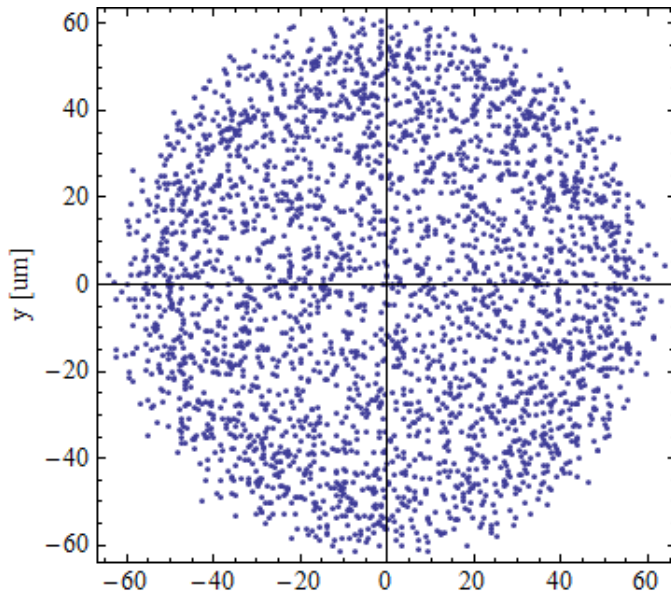

Beam after photoinjector (w/o AM)
 $\epsilon_{xn} = \epsilon_{yn} = 2.8 \times 10^{-8}$ m-rad

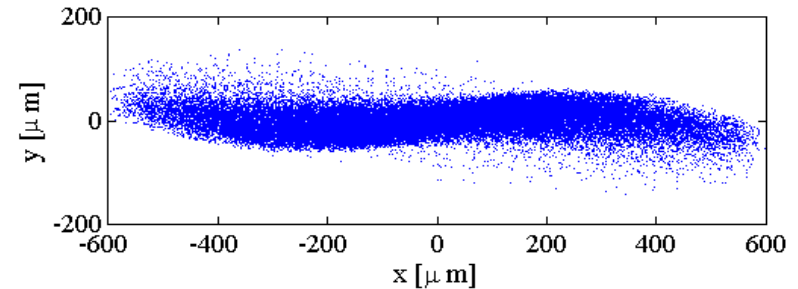

Beam after splitter

Normalized Emittance
 $\epsilon_{n-}, \epsilon_{n+} = 2.9 \times 10^{-9}, 2.6 \times 10^{-7}$ m-rad



Injector RF design and engineering

- S-band “Super-Gun” permits 160 MV/m injection
- 7 MeV beam, $\sim 3\times$ current B_e
- “Disruptive” to FEL comm.
- Fabrication at RadiaBeam

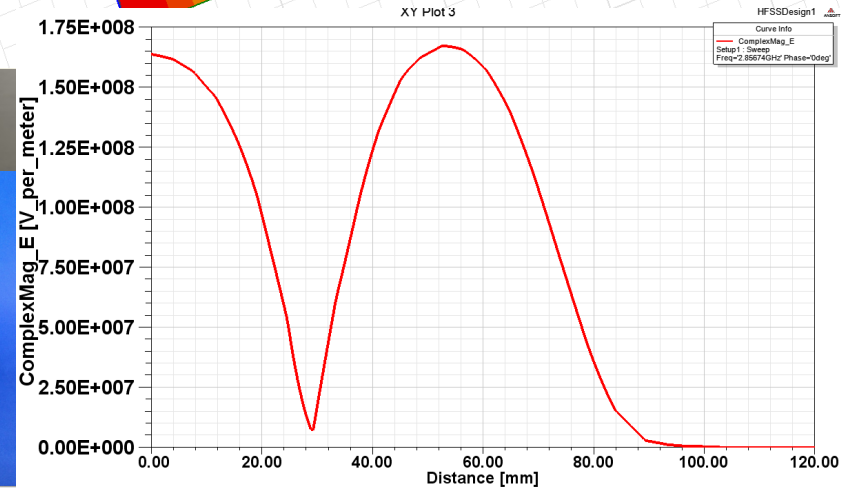
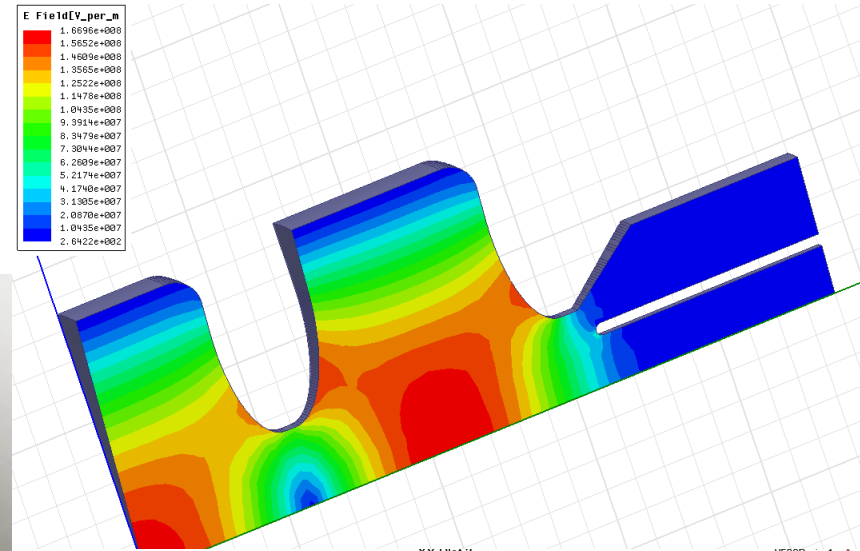
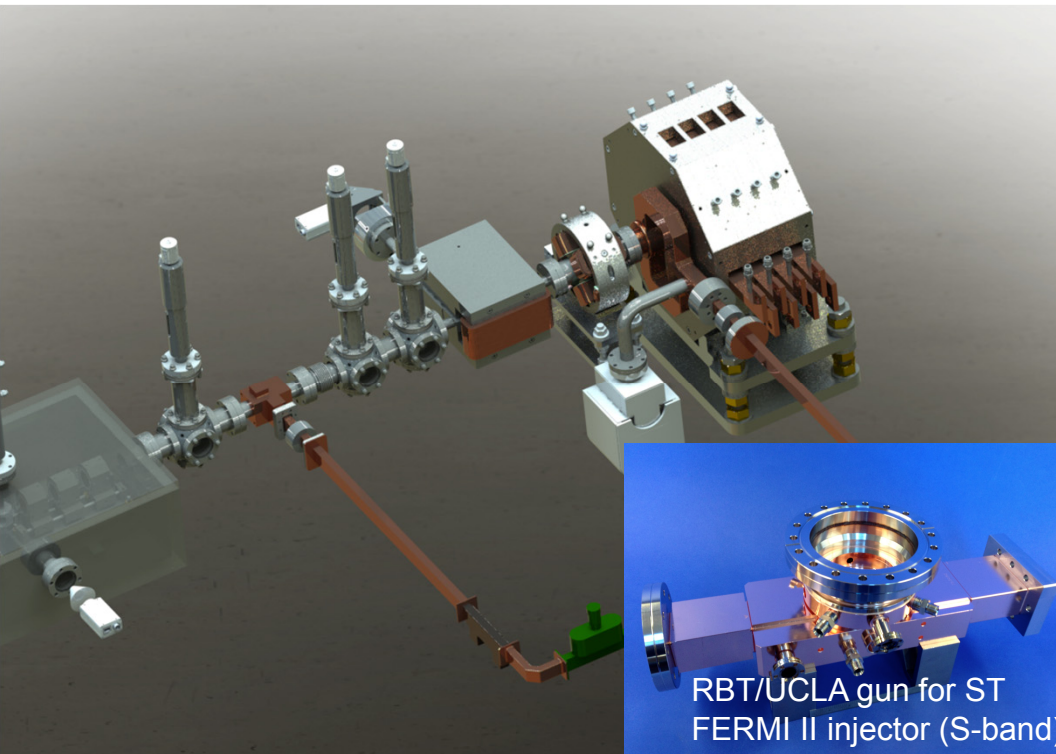

Creation and measurement of nm emittances

- New dark-field technique pioneered at UCLA Pegasus
 - Low gradient RF gun
- Uses TEM grid, edge distribution – 10 nm ϵ resolution

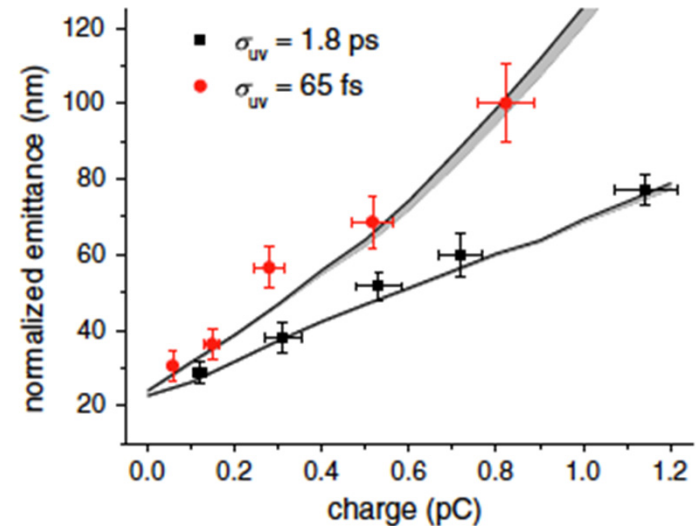
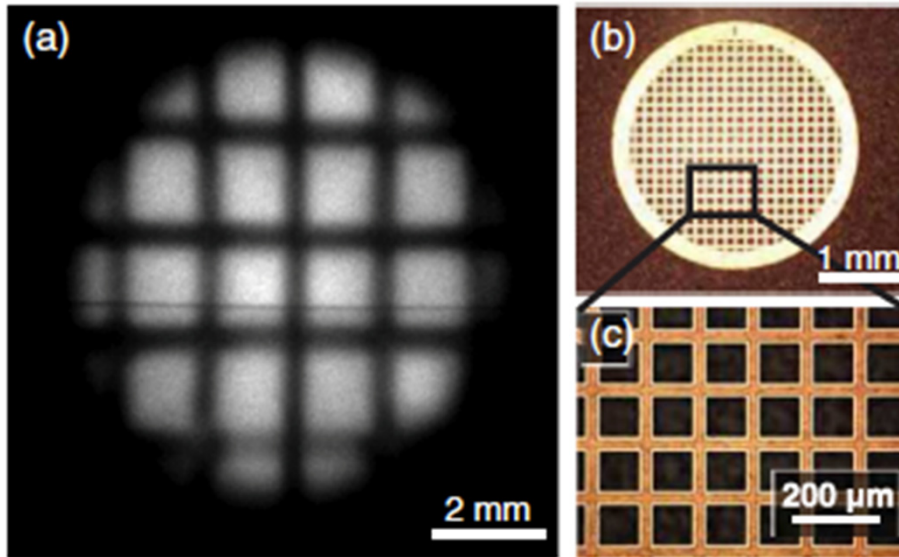

R.K. Li, et al., Phys. Rev. ST-Accel Beams 15 090702 (2012)



GALAXIE GV/m DLA structure

- Myriad challenges:
 - Optimized field on dielectric (GV/m breakdown)
 - Novel wavelength (5 μm)
 - Photonic confinement (no metals allowed)
 - Beat Earnshaw's theorem (y. 1842!), obtain simultaneous transverse & longitudinal focusing
 - Utilize a continuous coupling to yield long interaction between DLA and e-beam
 - *Fabrication.* Start with Si, aim for sapphire later...



Optimized DLA structure design

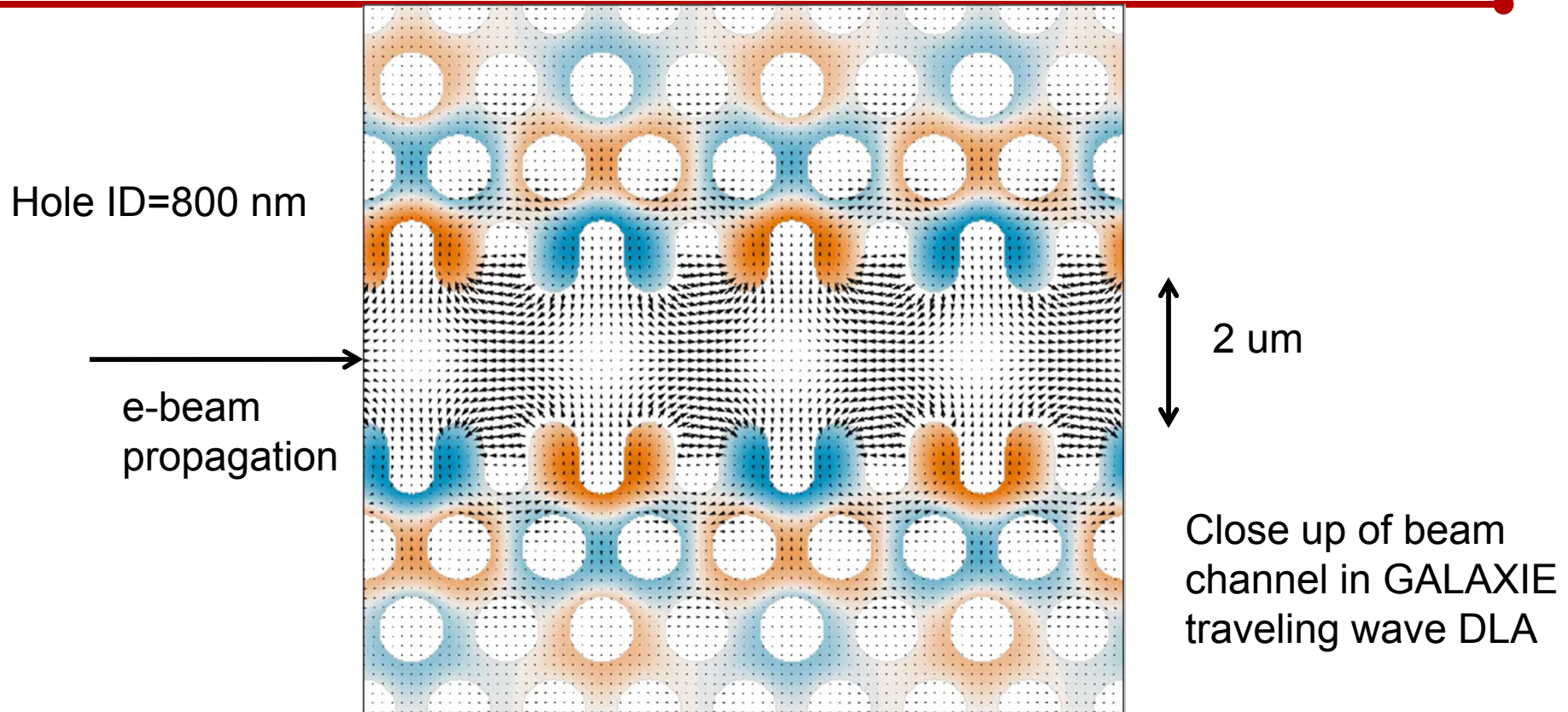

- *Single material (Si, Al₂O₃) photonic structure*
- Rich spatial harmonic spectrum
- Described in recent PRL
 - Naranjo, Valloni, Putterman, Rosenzweig, *PRL* 109, 164803 (2012)

Focusing and acceleration provided by nearby spatial harmonics

Focusing given by 2nd order interaction with non-synchronous fields

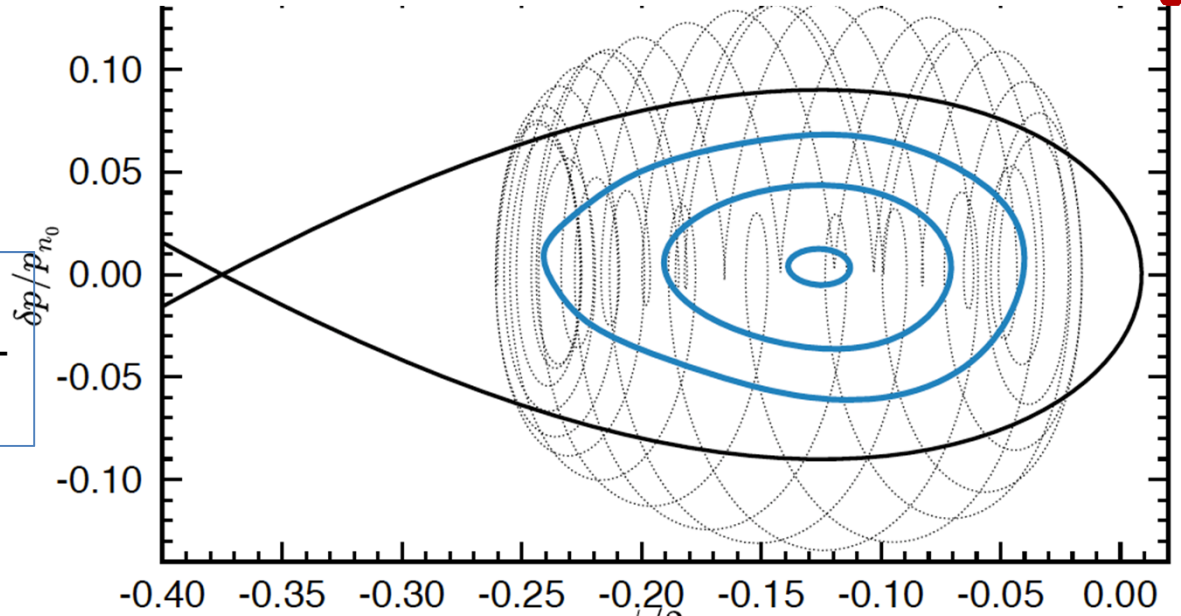

Longitudinal phase space (Poincaré and actual). Note bouncing due to harmonics

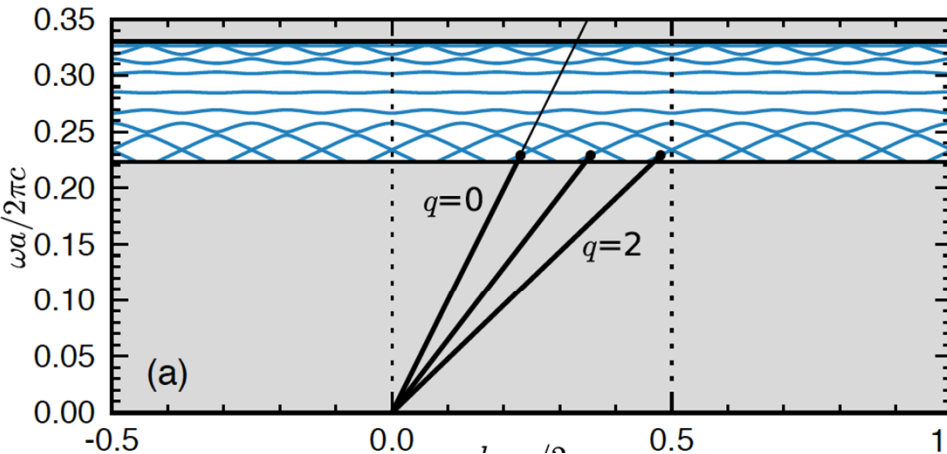

Brillouin diagram for GALAXIE structure

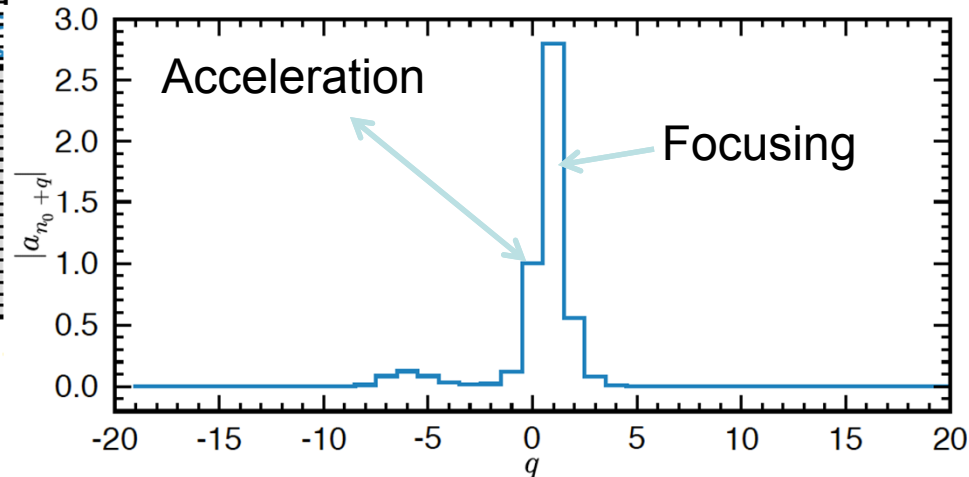

Laser-Structure Coupling

Dual laser drive structure, large reservoir of power recycles

Laser pulses
(180 degrees
out of phase)



e-beam

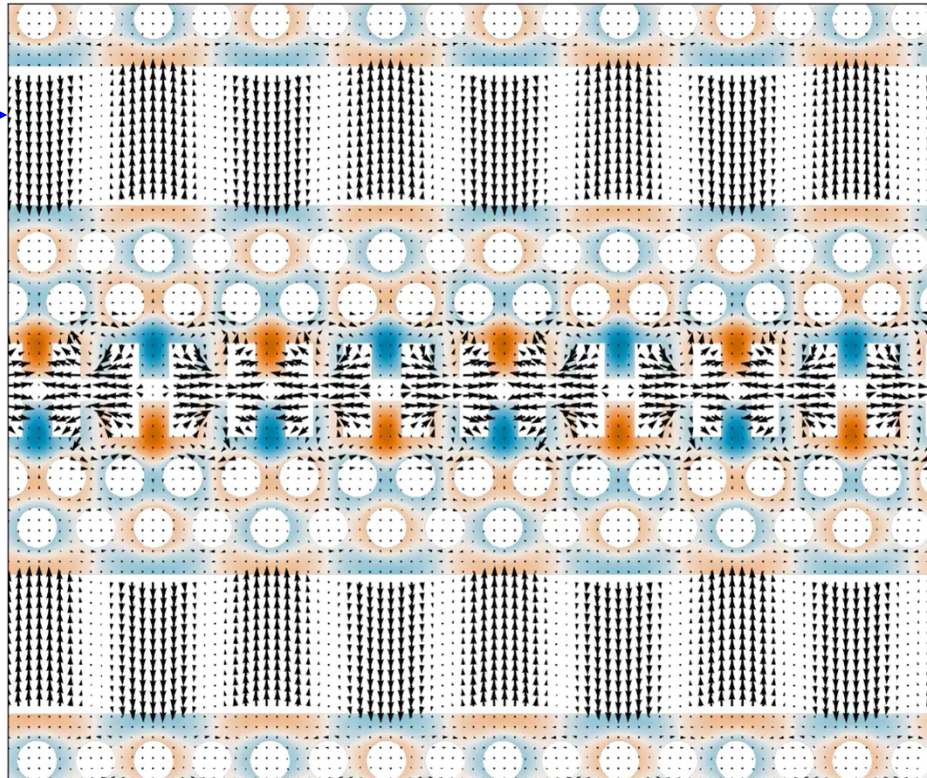

“Rolling” coupling to give synchronism between beam and v_g

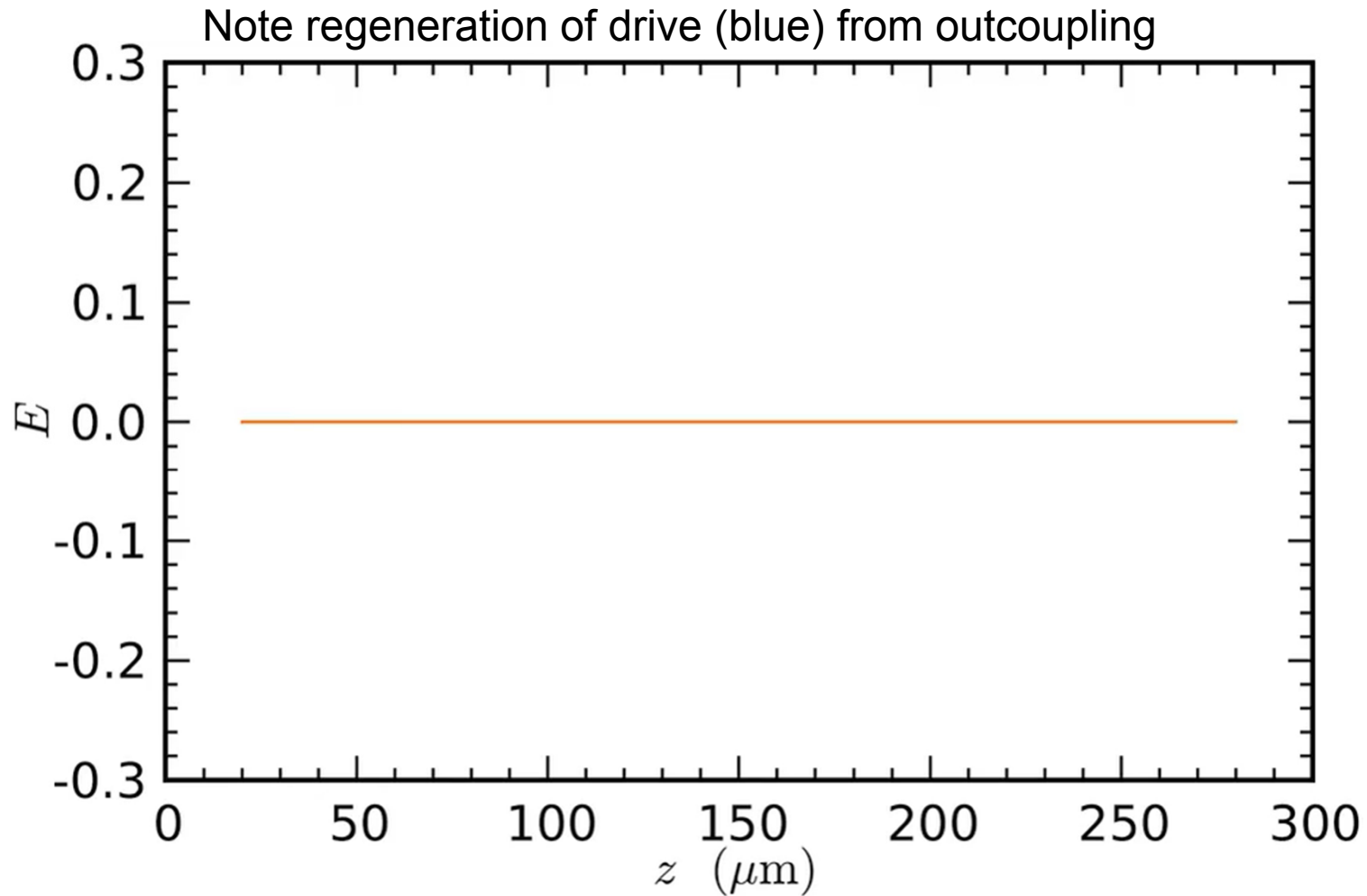

Beam dynamics: injection to final energy

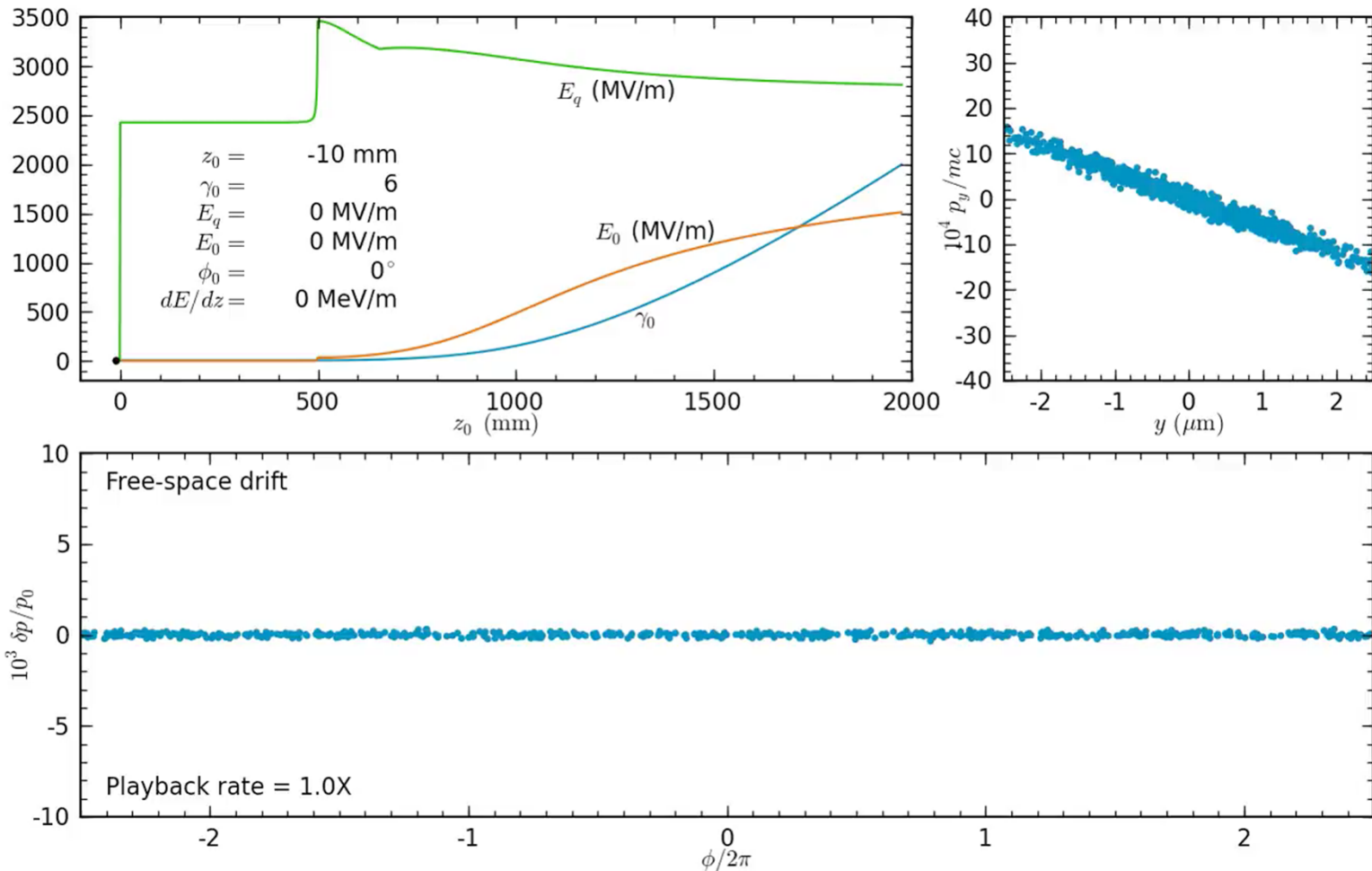

Adiabatic: (1) focusing (2) capture (3) compression (x1000!)

Under preparation for PRSTAB



Collective effects beyond space-charge: wakefields

- 1st observation of *slab-symmetric* dielectric structure wakes
 - Key for DLAs: mitigates wakes, space-charge, beam loading
 - Coherent Cerenkov radiation benchmark on mode frequencies
 - Deceleration/acceleration observed (several 100 keV); STE simulated

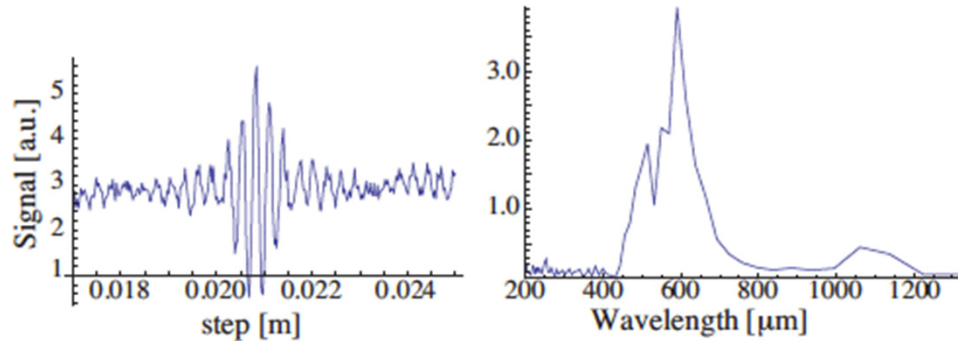
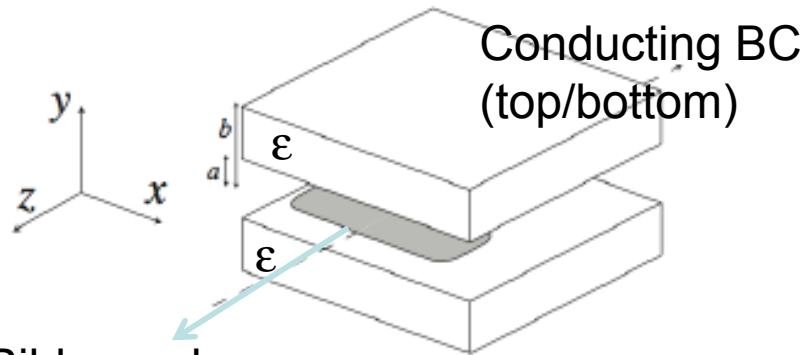

CCR signal and FFT

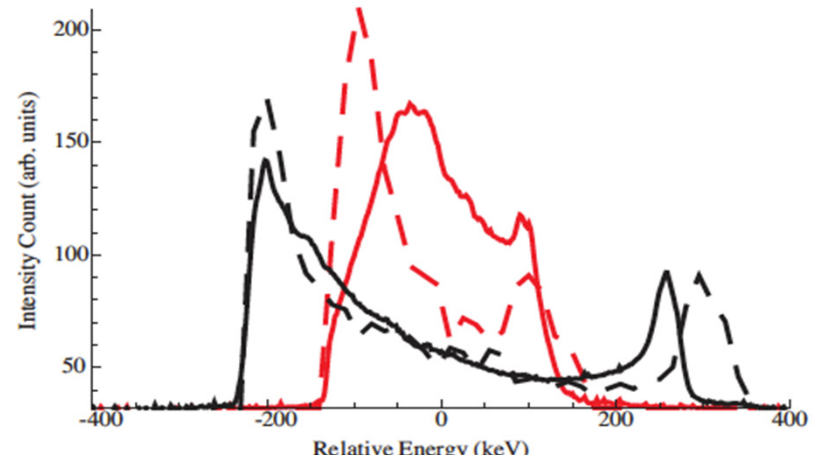

Observed (solid) and simulated (dashed) momentum spectra

G. Andonian, et al., *PRL*108, 244801 (2012)

Photonic device wakes I: Bragg

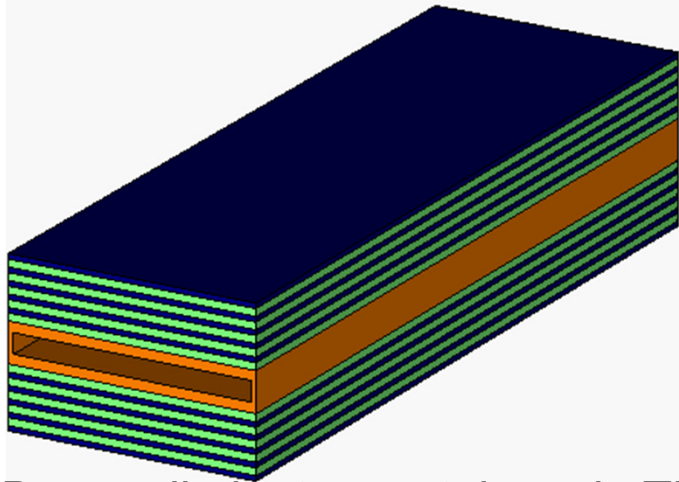

Bragg eliminates metal use in THz

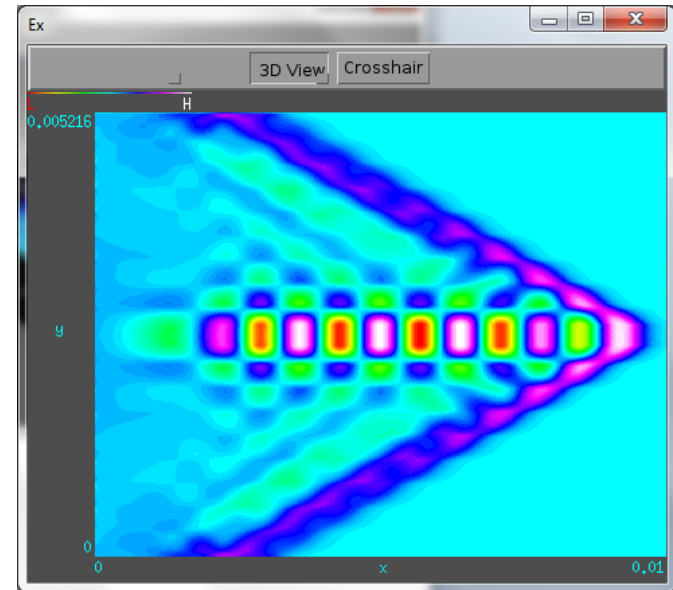
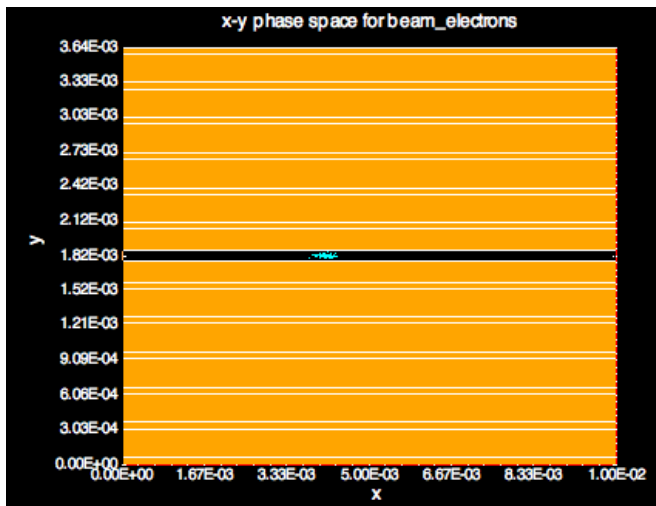

VORPAL simulation

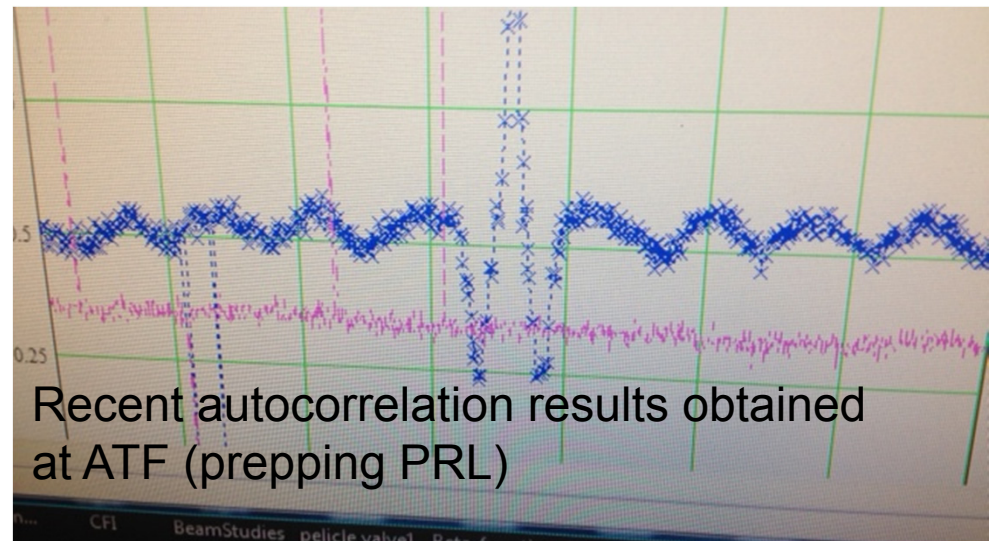

Recent autocorrelation results obtained at ATF (prepping PRL)

Simple 2D photonics (1st of its kind)
Quartz (also matching layer) + ZTA

New studies at FACET and BNL ATF

- Very high field longitudinal wakes
 - >5 GV/m DWA before breakdown in THz
- New, photonic structures
 - Woodpile (canonical), scaled GALAXIE

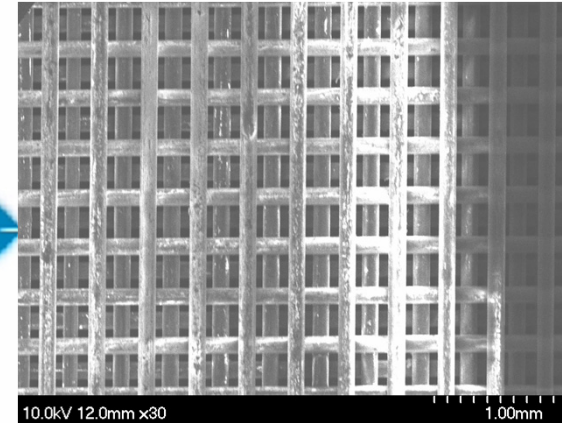
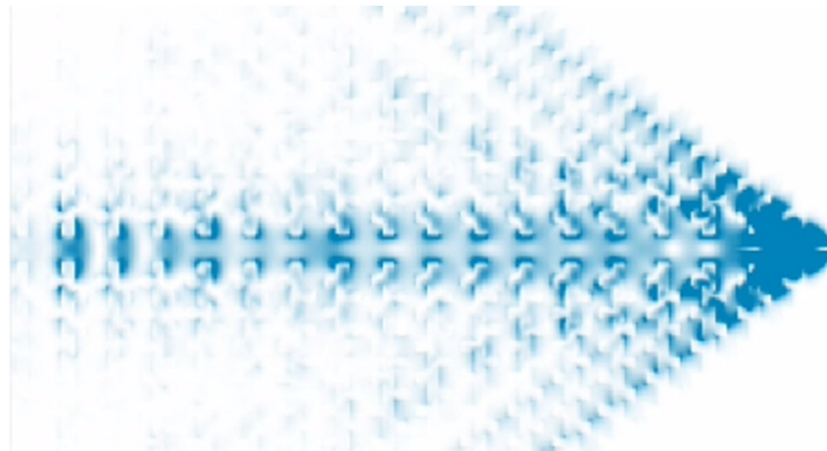
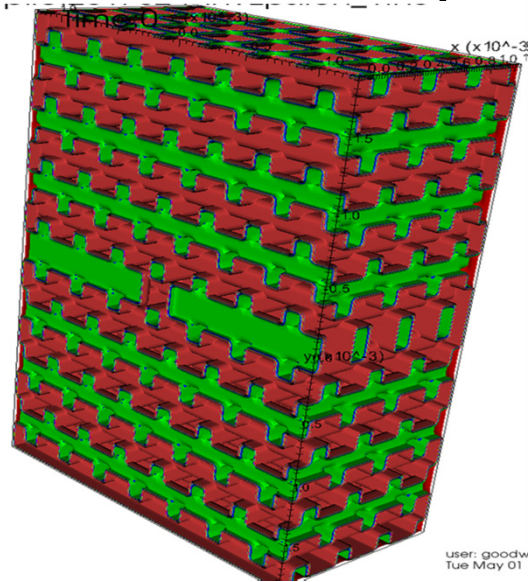

Photonic structure (woodpile) wakes; as constructed (left)



New FACET results

- GV wakes in tubes and slabs observed

Interferogram

Processed Data

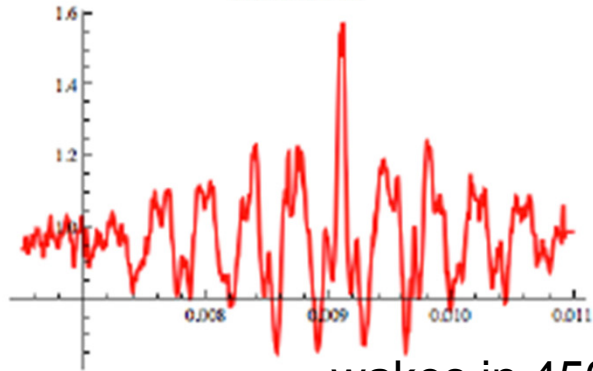

FFT

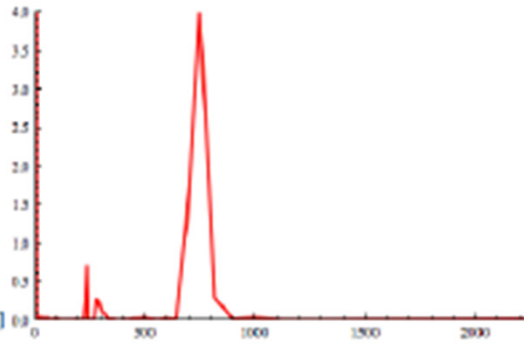

wakes in 450 um ID tubes

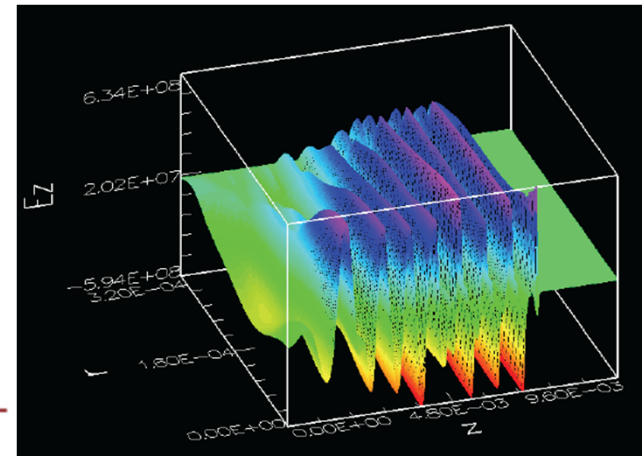

OOPIC sims of tube wake

- 100 MW narrow band THz source!
- On to Bragg, woodpile...



Next generation wakes: 3D photonics

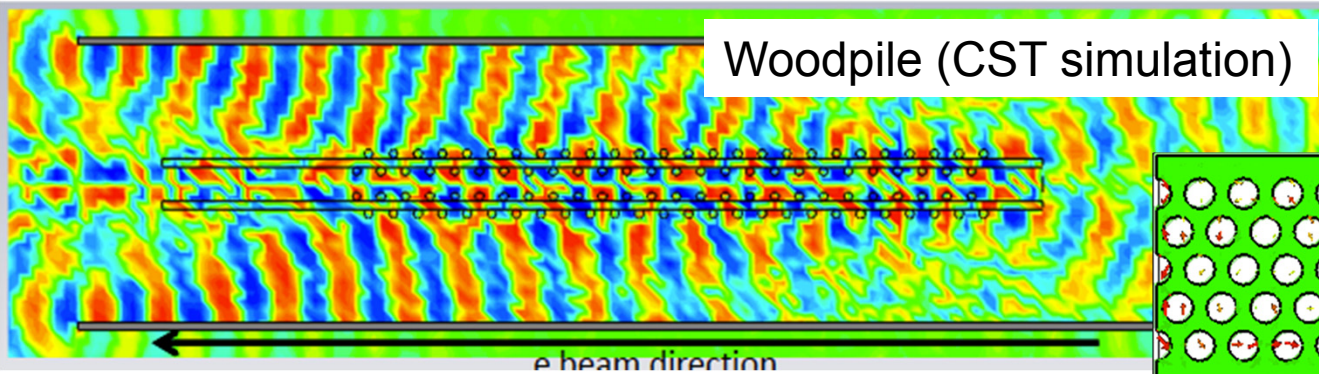

- Woodpile fabricated
 - June 2013 test at ATF
- Scaled GALAXIE structure fabricate by *laser assisted etching* of sapphire

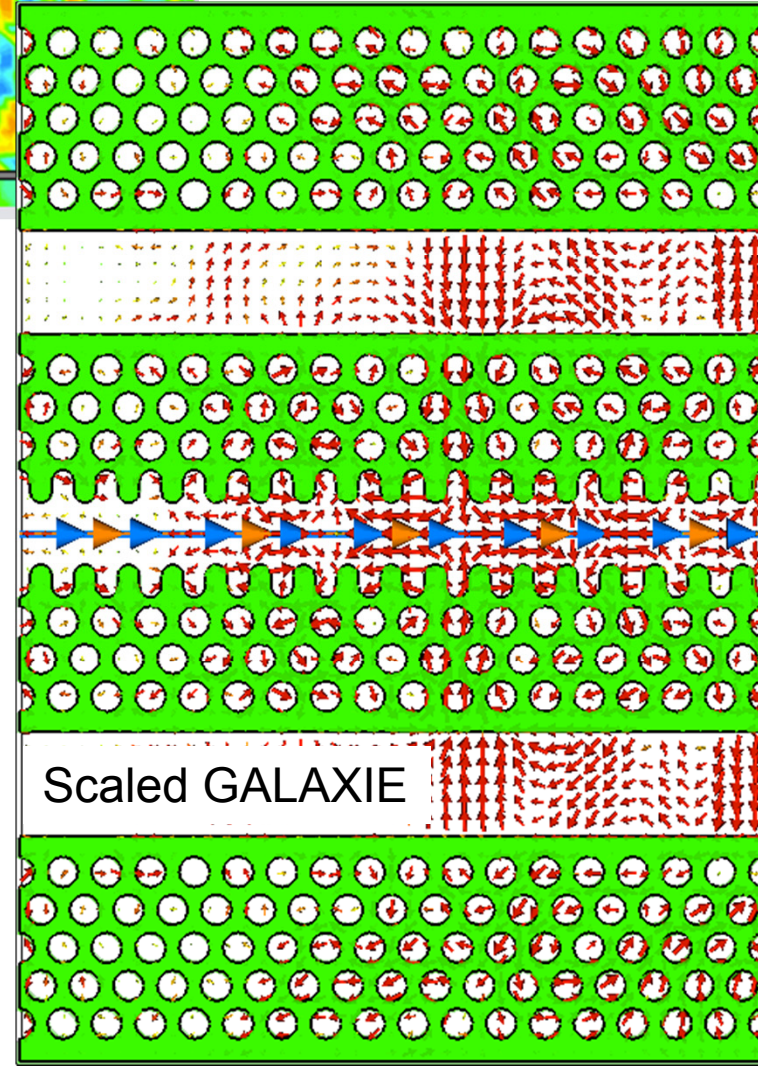

Integration studies (and their lessons)

- Need μm beam diagnostics (coherent imaging, λ -scale)
- Develop $\mu\text{-beam}$ optics (Candler group)

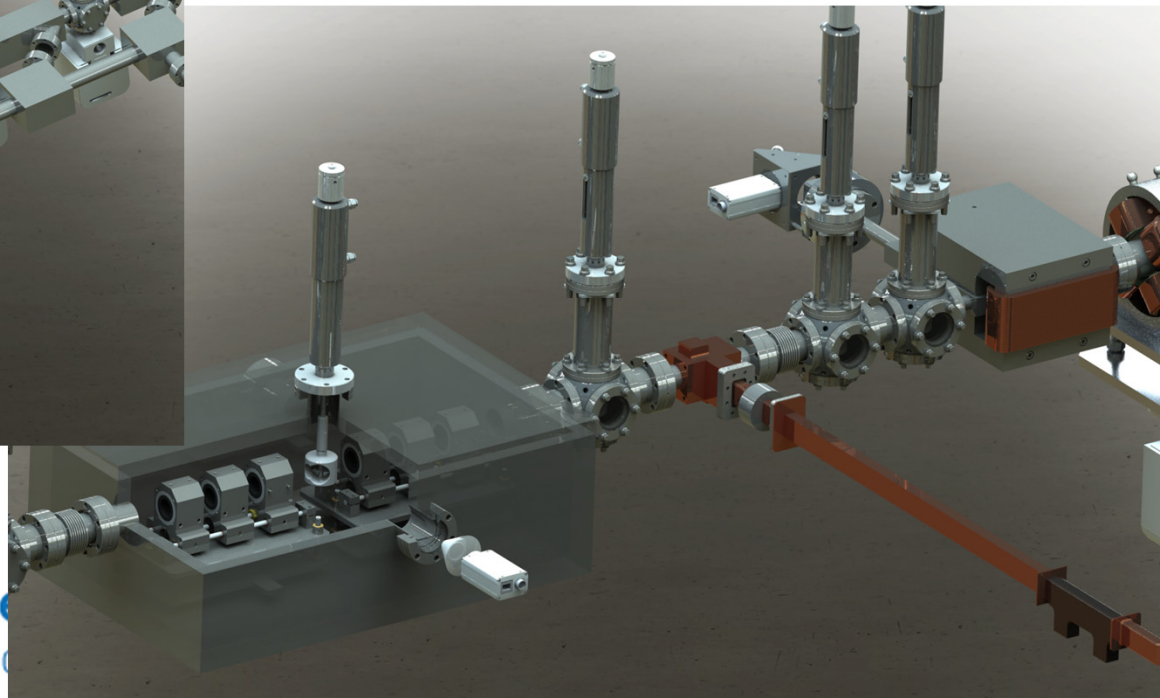
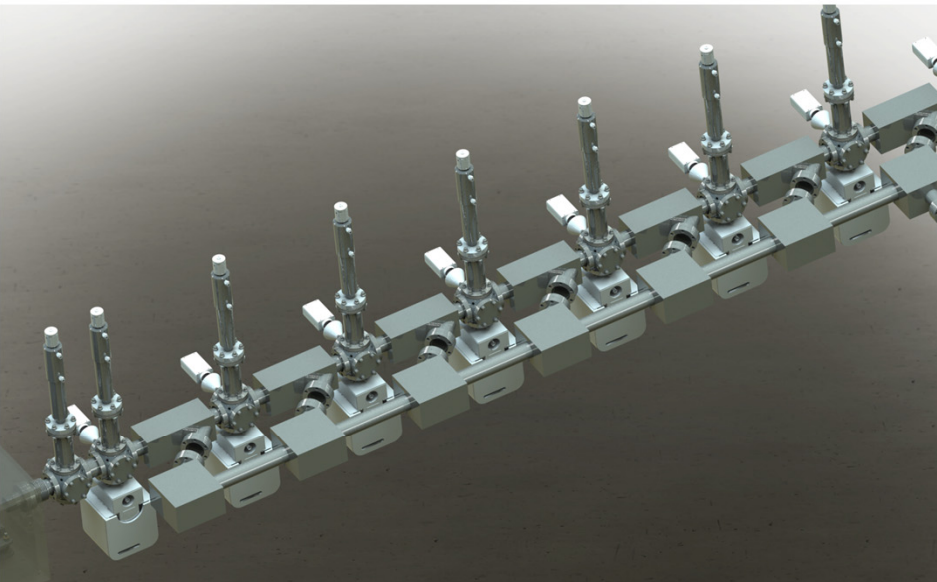
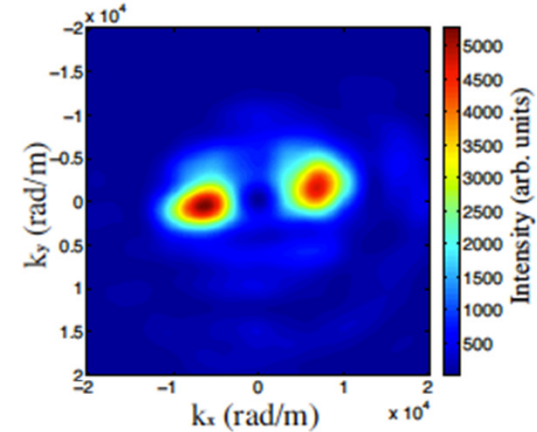

Integration studies (and their lessons)

- Need um beam diagnostic (coherent imaging, λ -scale)
- Develop μ -beam optics (Candler group)

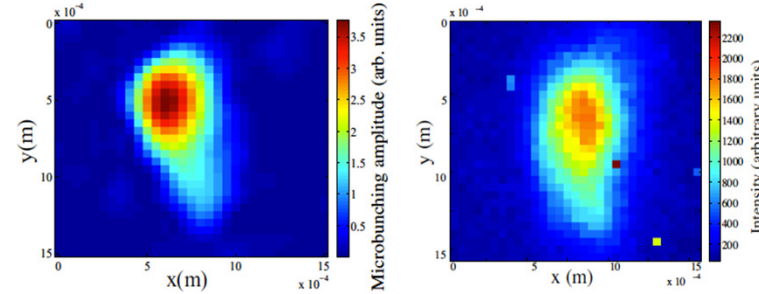
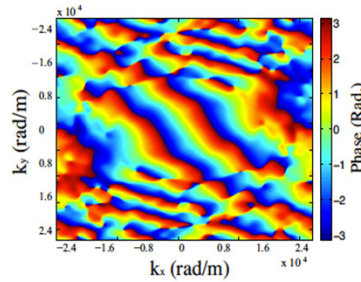

A. Marinelli et al., *Phys. Rev. Lett.* 110, 094802 (2013). UCLA expts. at SLAC

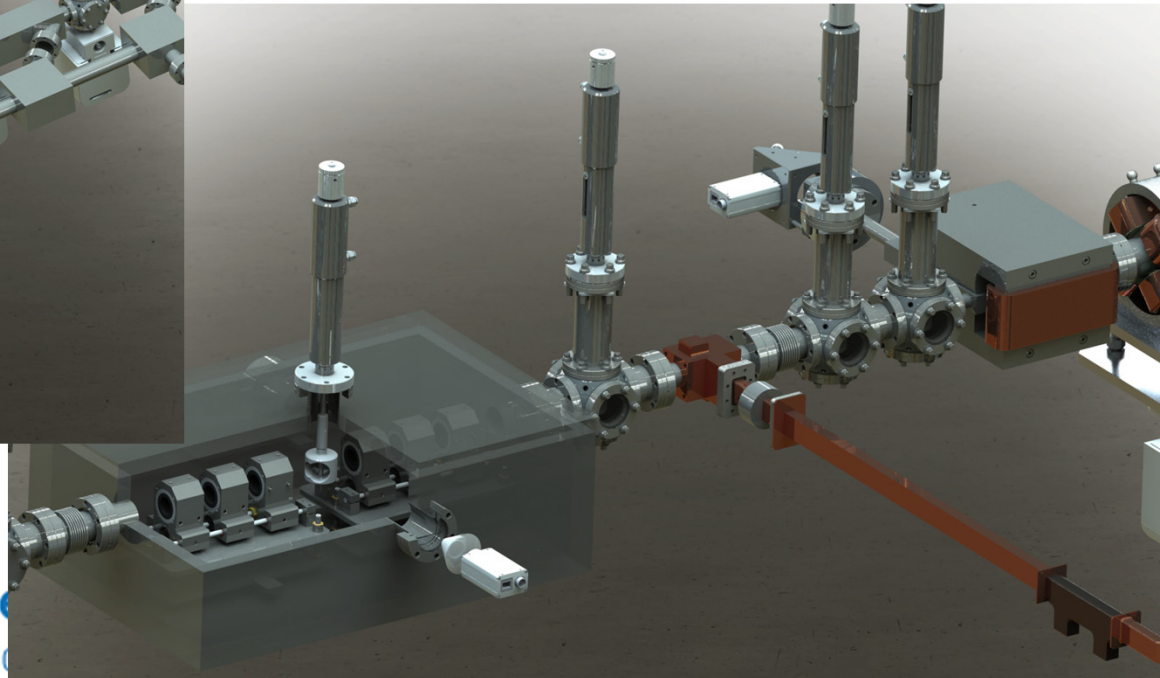
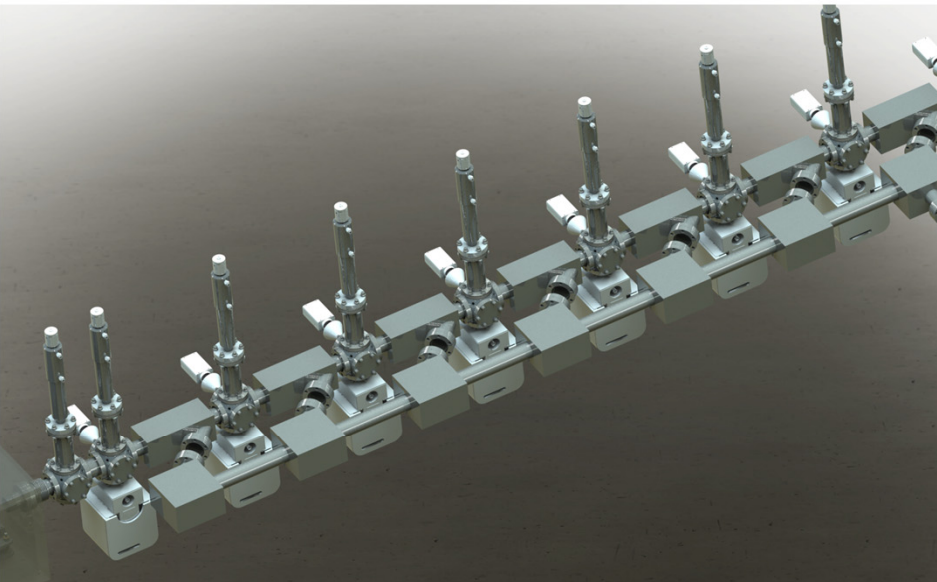

MEMS Quadrupole Focusing Magnets

Courtesy R. Candler (UCLA), B. Jacobsen (RBT)

Technology μ machined Electromagnets

∇B $>3,000$ T/m

Inner diameter 200 μ m

Tuning Electromagnet

Beam Parameters

Energy 12 MeV

Charge 1 pC

Emittance 20 nm

Energy spread 0.05 %

Bunch length 200 fs (10 fs compressed)

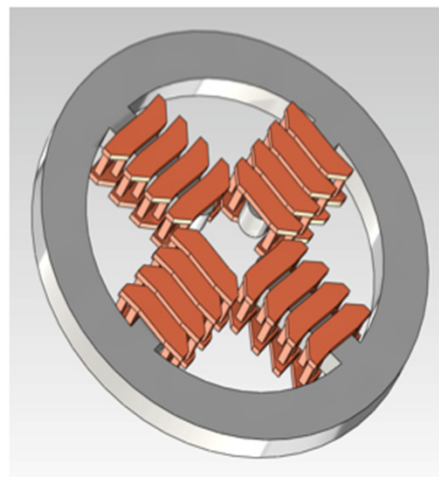
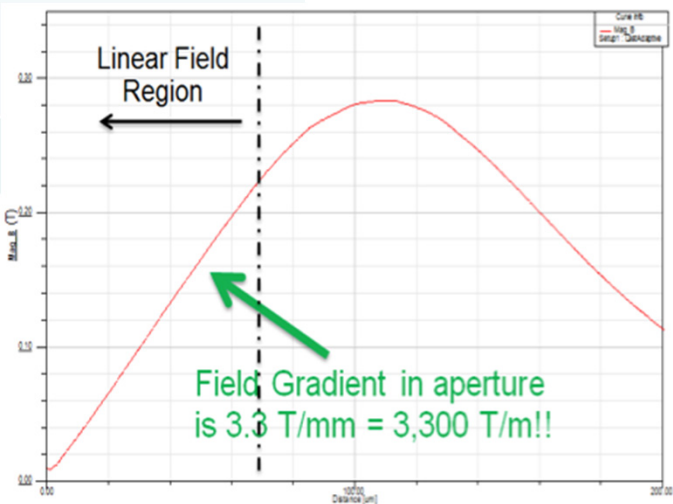

Very compact, short focal quads!
Numerous applications (FEL, ICS, PWFA)



At screen (simulation)



MEMS Quadrupole Focusing Magnets

Courtesy R. Candler (UCLA), B. Jacobsen (RBT)

Technology	μ machined Electromagnets
∇B	>3,000 T/m
Inner diameter	200 μ m
Tuning	Electromagnet

Beam Parameters

Energy	12 MeV
Charge	1 pC
Emittance	20 nm
Energy spread	0.05 %
Bunch length	200 fs (10 fs compressed)

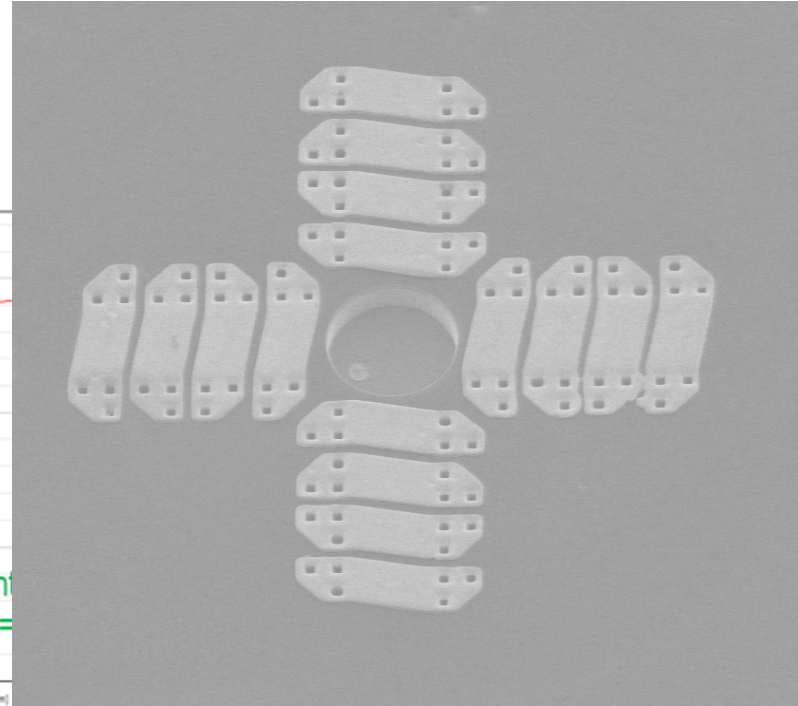
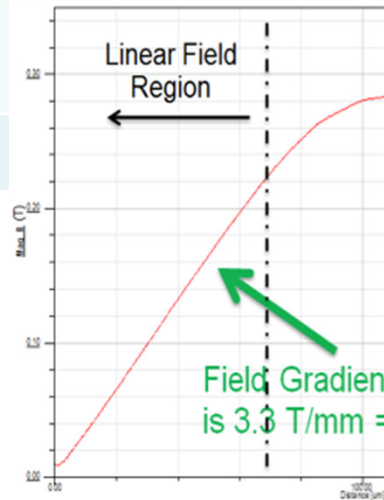

Very compact, short focal quads!
Numerous applications (FEL, ICS, PWFA)



At screen (simulation)

Development of 5- μm laser at PSU

Poster WEPME063 (G. Xu, S. Wandel, I. Jovanovic)

Future: direct pumping by Tm/Ho/Cr-based high-energy short-pulse laser

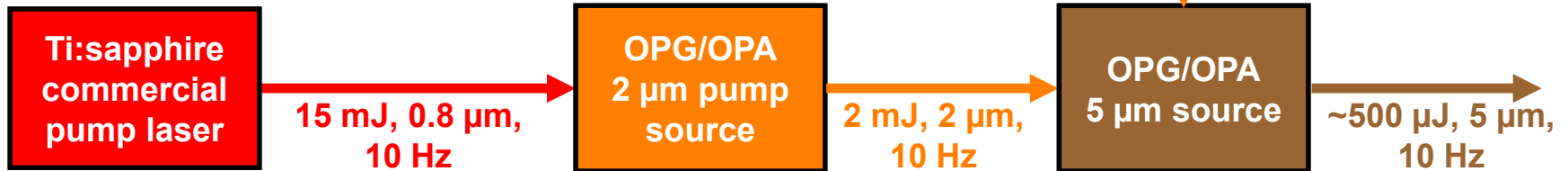
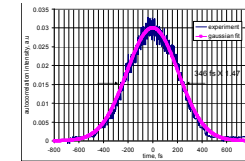
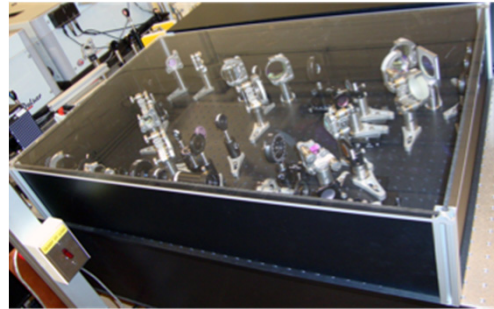

BBO: 2 μm



ZGP: 5 μm

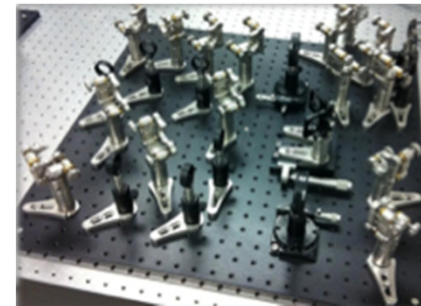

High-energy, compact 2- μm source produces high quality, <100 fs pulses

High-energy 2- μm OPA (2' x3')

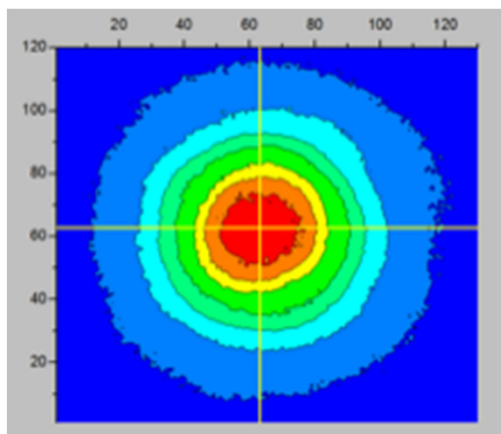
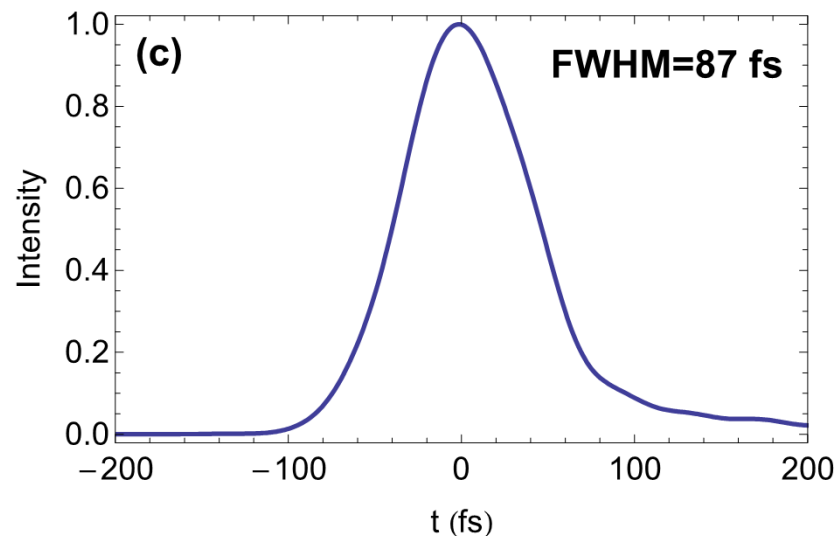
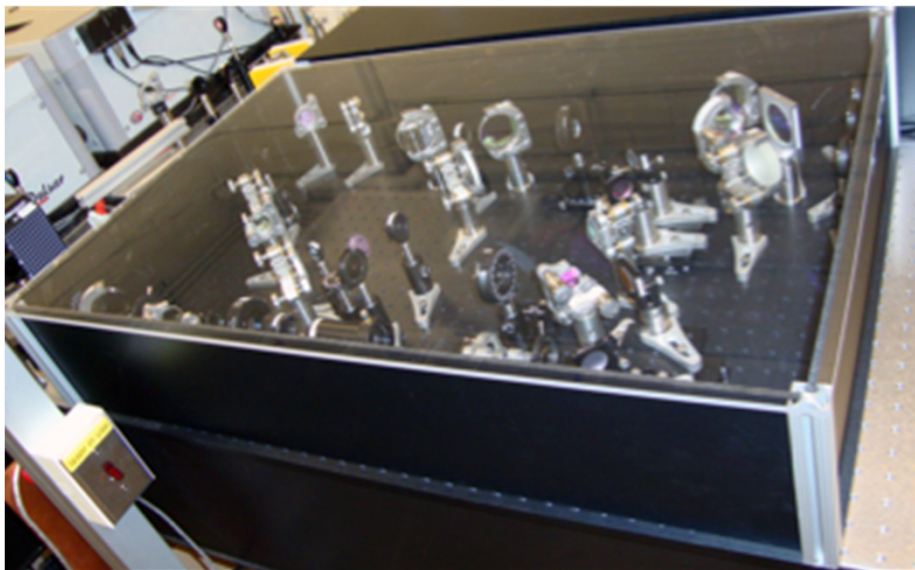

Large-aperture
BBO crystal is
used as OPA.



2.2 mJ pulses now generated at 2 μm

OPA 1

0.8 μm pump: 795 μJ
1.3 μm signal: 58 μJ
(after energy losses on beam expander and dichroics)



1:7 beam expander

OPA 2

0.8 μm pump: 14.3 mJ
1.3 μm signal: 3.65 mJ
2 μm idler: 2.2 mJ
(after energy losses on beam expander and dichroics)

Pump pulses
at 792 nm

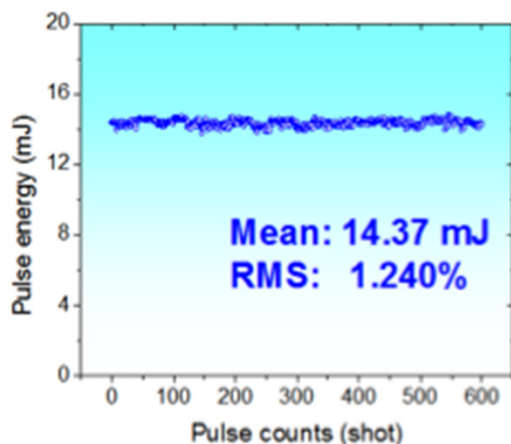

Idler pulses
at 2.05 μm

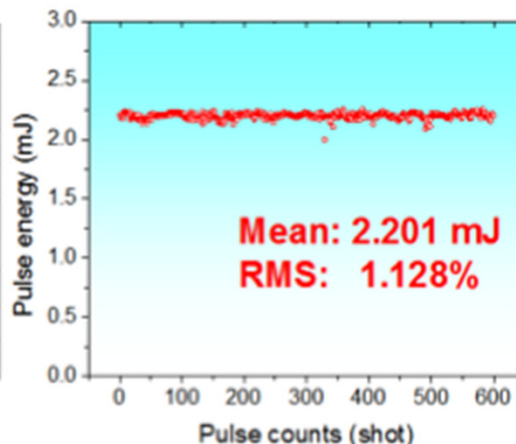

Signal pulses
at 1.29 μm

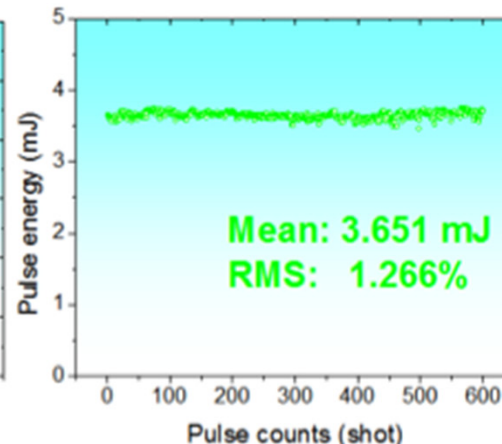

5- μm source layout

ZGP Type I Phase Matching
2.0 μm (o) \rightarrow
3.3 μm (e) + 5.0 μm (e)



1-mm-thick ZGP with a cut angle of 56.1° is used in OPG and OPA

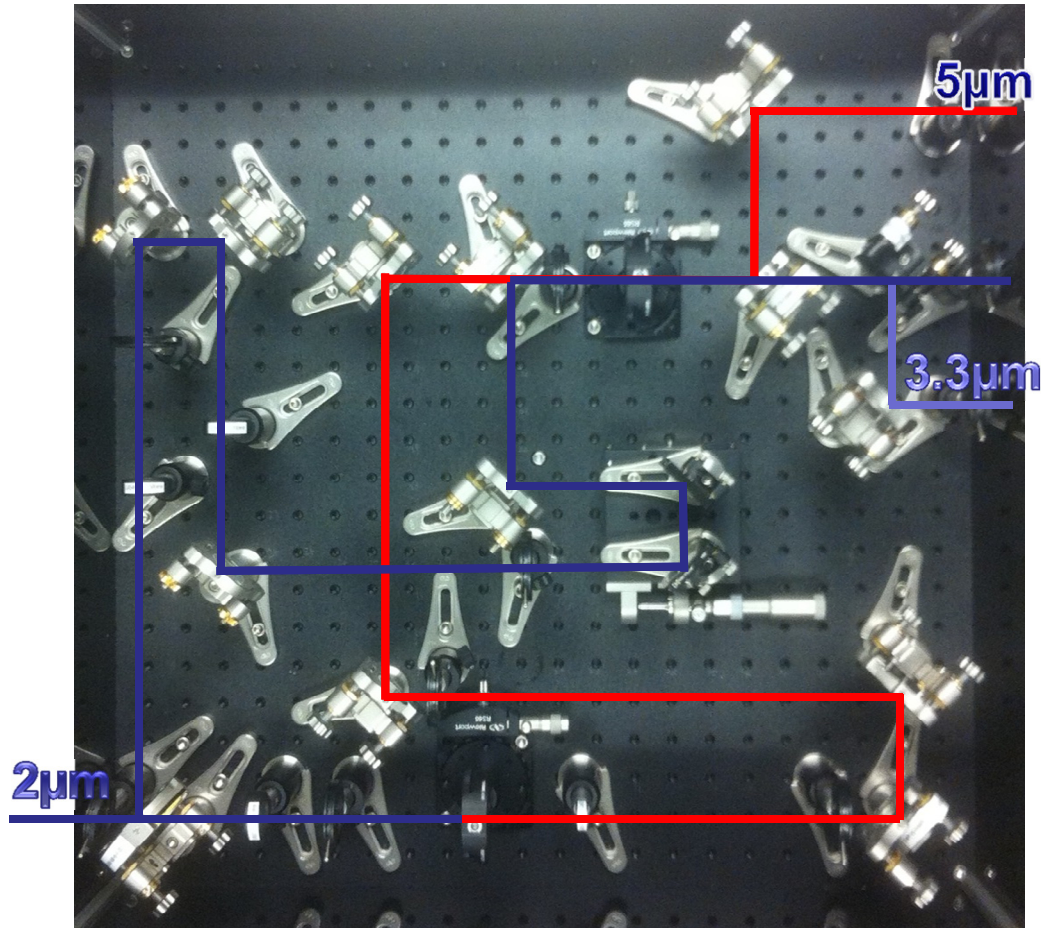

5- μm source performance to date

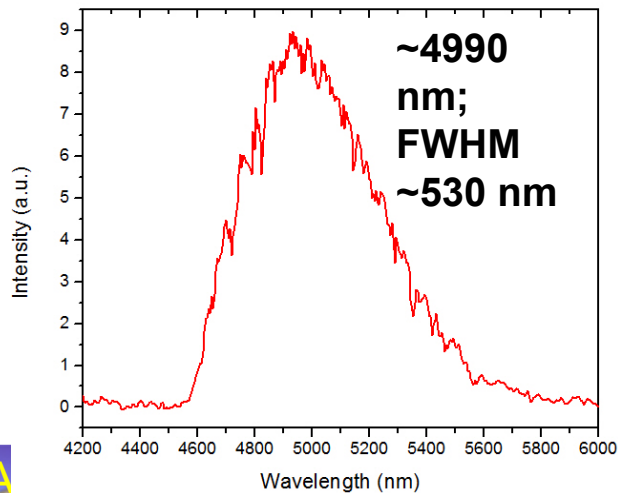
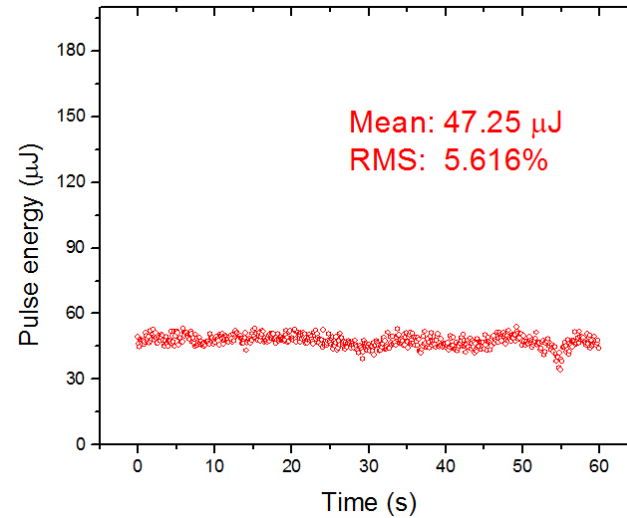
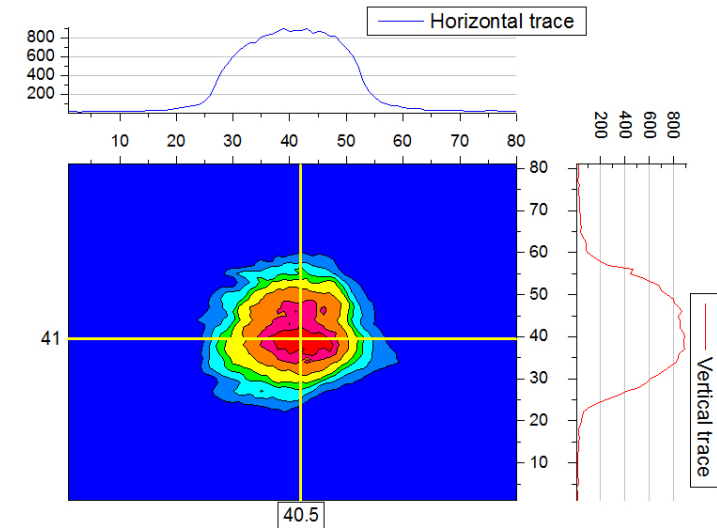

5 um testing of structures: INRWA

- Infrared Network Analyzer (IRNWA)
- Based on Palitra OPA (Quantronix).
- Up to 0.5 mJ at 5 um
- Test 5 um structures fabricated at UCLA

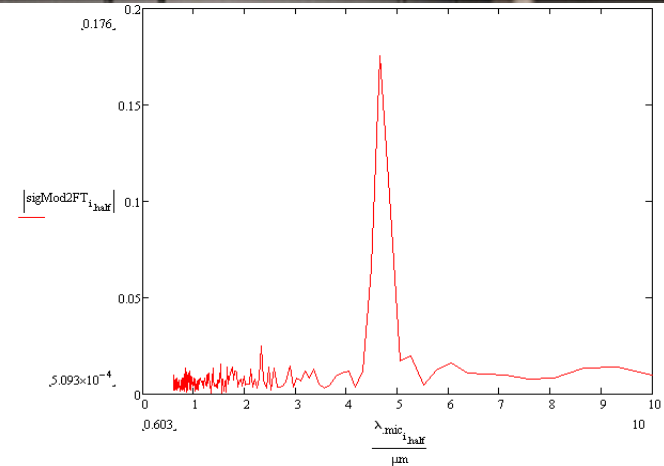
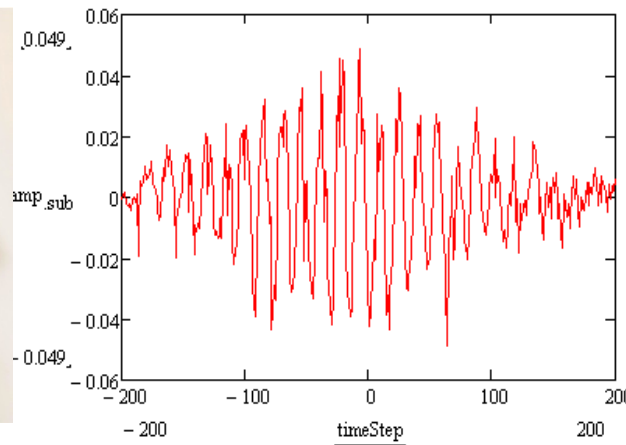
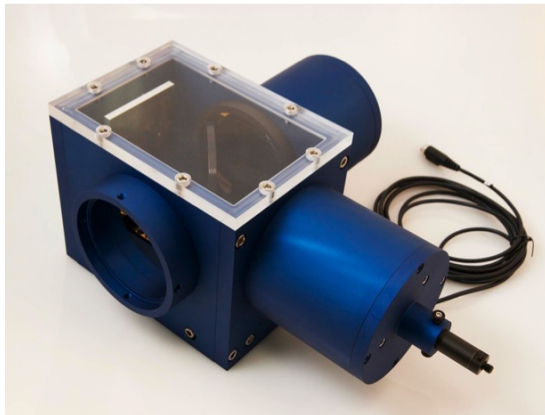
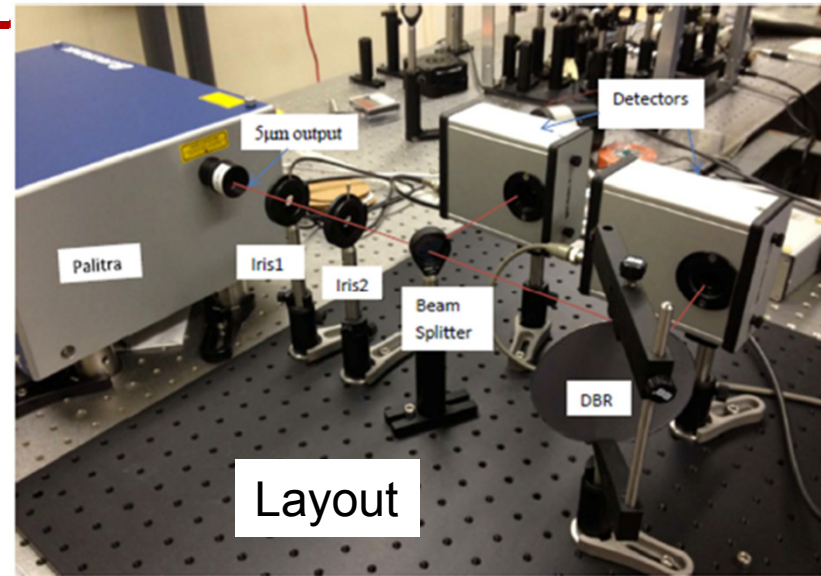

Autocorrelation of 5 um pulse from Palitra



Upgrades in IRNWA performance

- Precision measurements with QCL and spectrum analyzer
- High power in sub-ps system: *breakdown?*

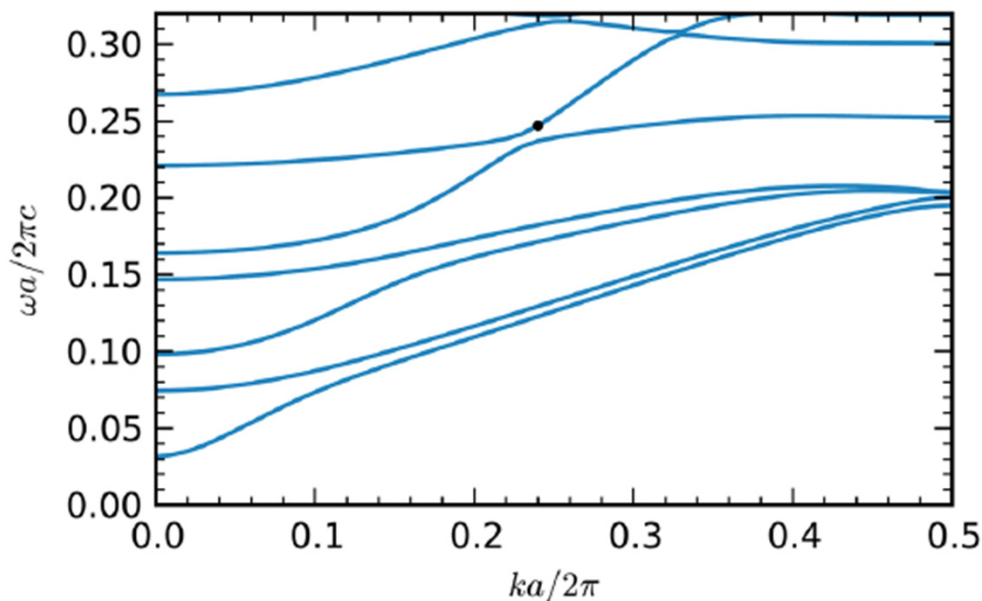

GALAXIE band diagram



Daylight solutions QCL (4/13)



Toptica wavelength meter



Material properties, breakdown at 5 μm

- Limited data on 5 μm light interactions
 - Index, loss tangent, *breakdown*
 - Long pulses more often studied.
 - Avalanche ionization dominant
- Study critical for:
 - Structure (accelerator)
 - Undulator (dielectric version)
 - Optical components
- Candidate material crystals
 - CaF₂, MgF₂, ZnSe, Ge, Si, Al₂O₃

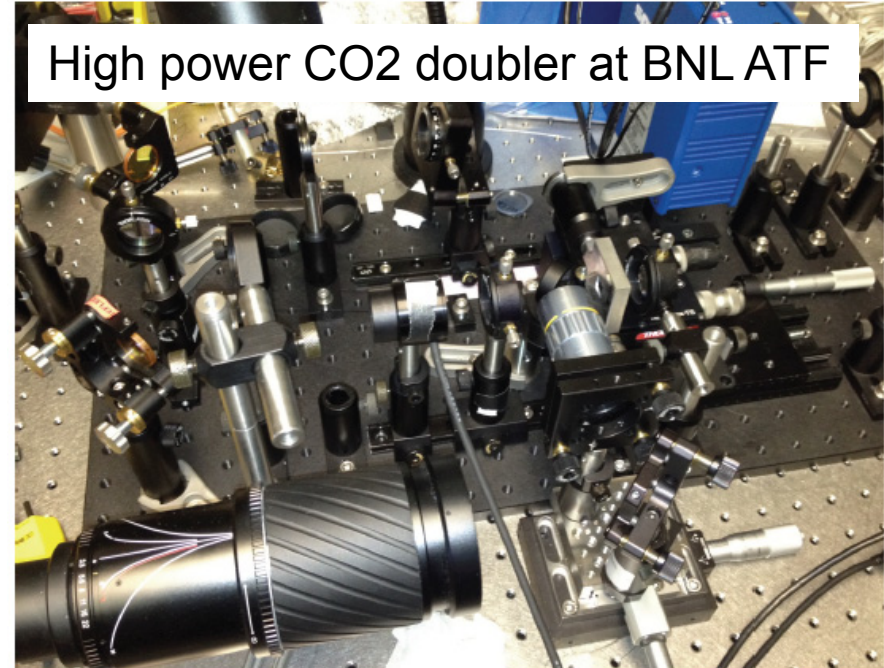

- CO₂ regen output ~15 mJ, 3 ps (long)
- 5 μm conversion target efficiency 30%
- peak 5 μm intensity=15 J/cm²



Breakdown in Si

- Peak field ~ 1.3 GV/m

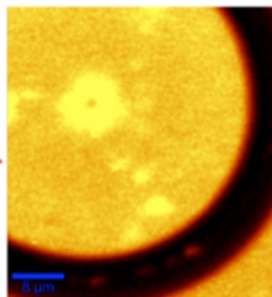
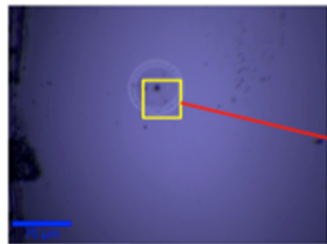
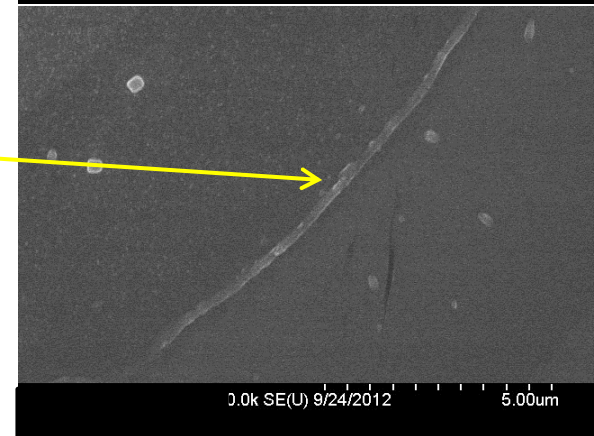
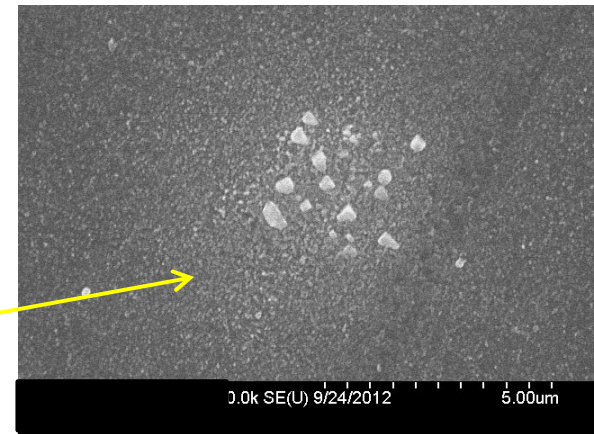
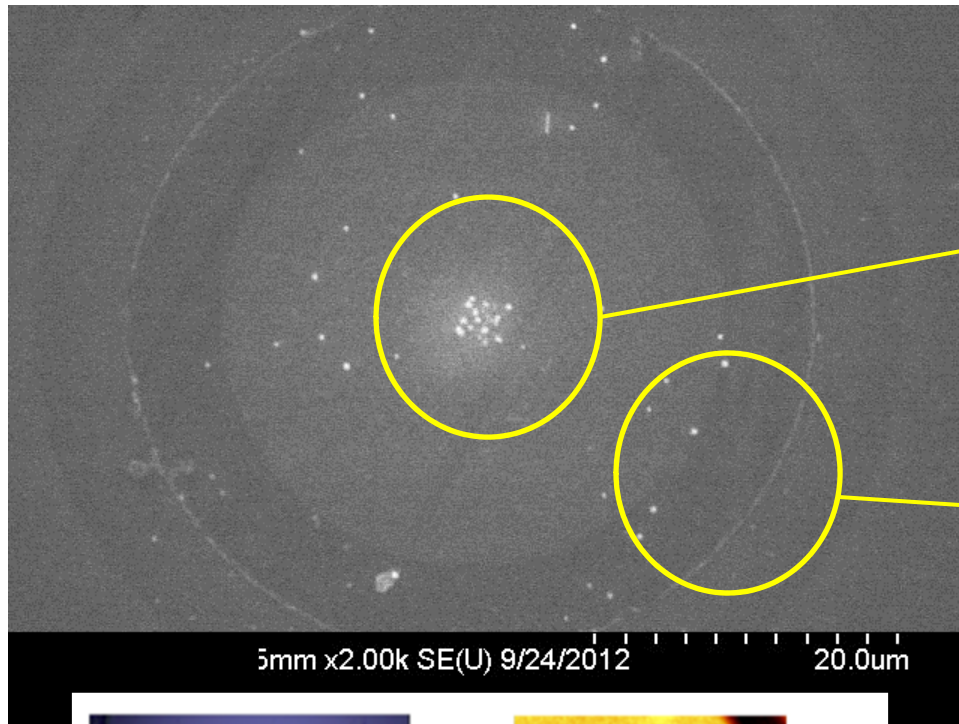

Breakdown in Ge

- Peak field similar to Si

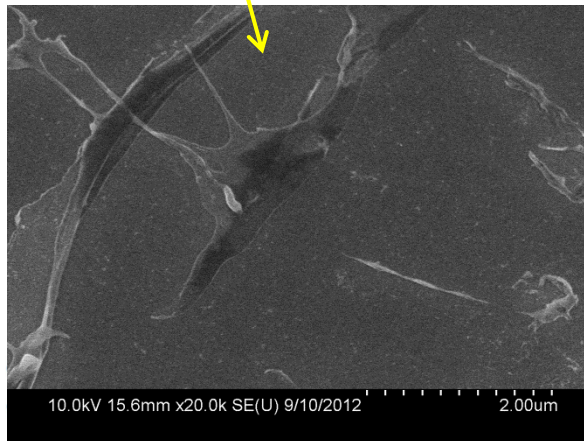
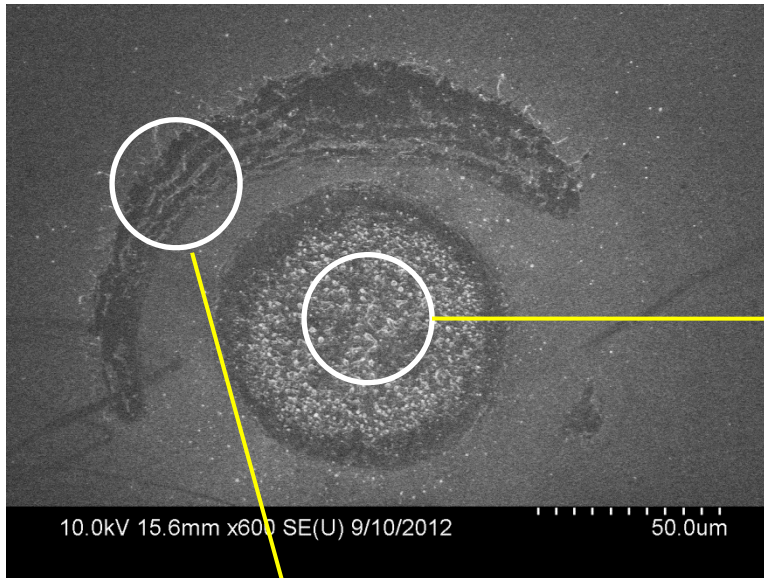

Breakdown in Sapphire

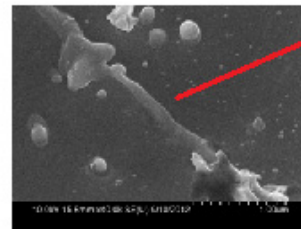
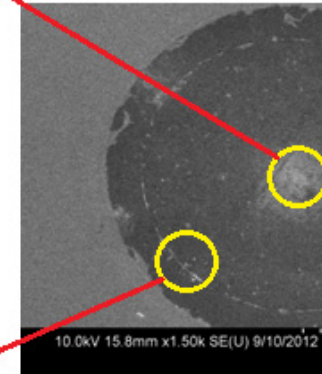
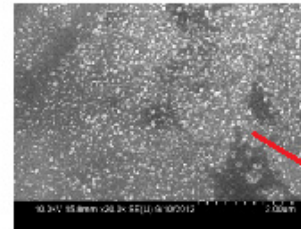
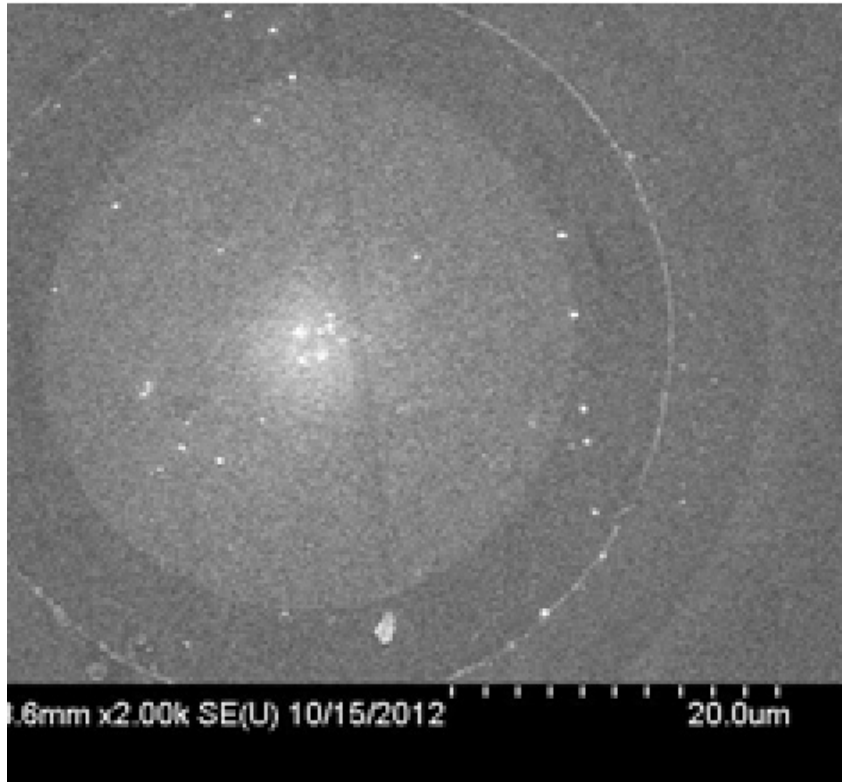

Breakdown > 4 GV/m fields, as expected (higher band gap material)



Beautiful Structure: How to Fabricate?

- UCLA Nano Laboratory provides fabrication capabilities for monolithic/joined structures
- Exploit structure features for 2-etch fabrication
- First step: “single layer” structure
- Next step: “stacking” studies

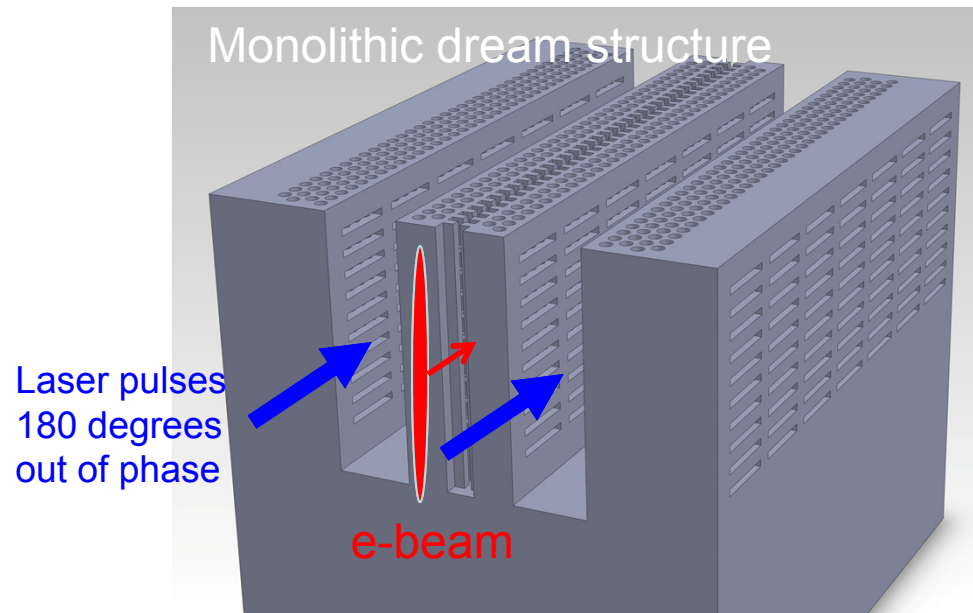

Main challenges:

- High aspect ratio holes
- Precision accelerator features



Single layer structure

- First tests of fab and mode structure
- On SOI, DRIE etch with wet undercut

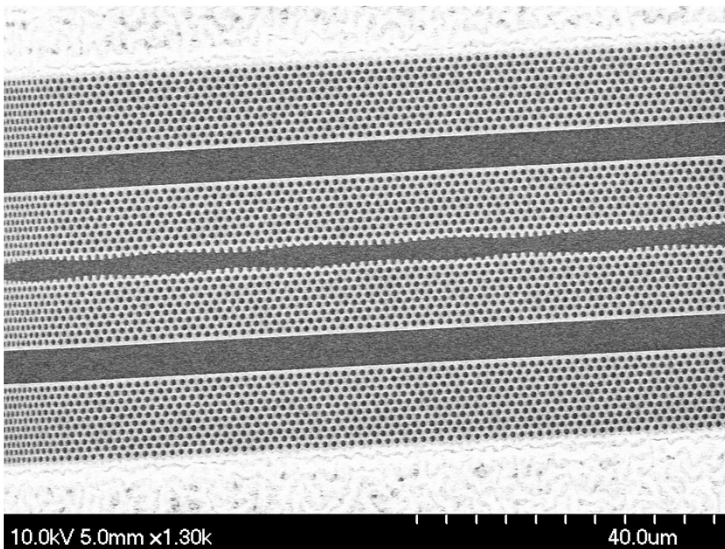
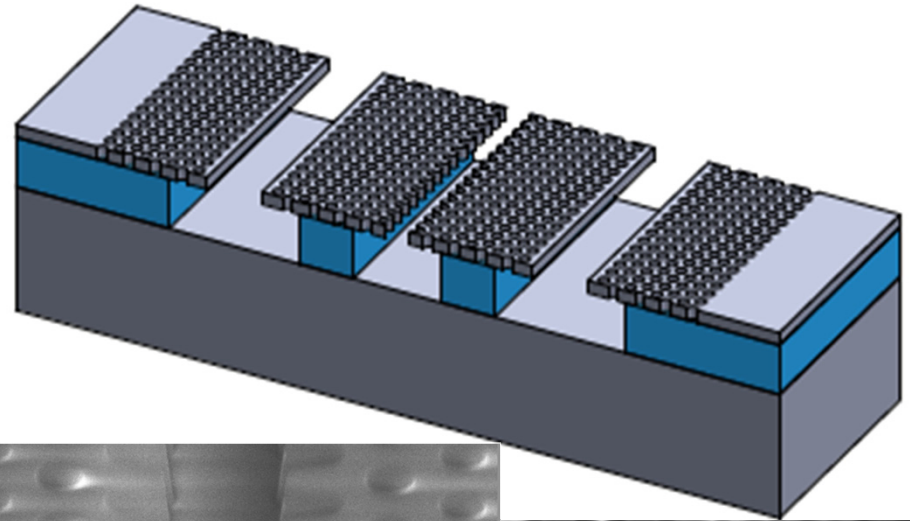

Mask for single layer structure

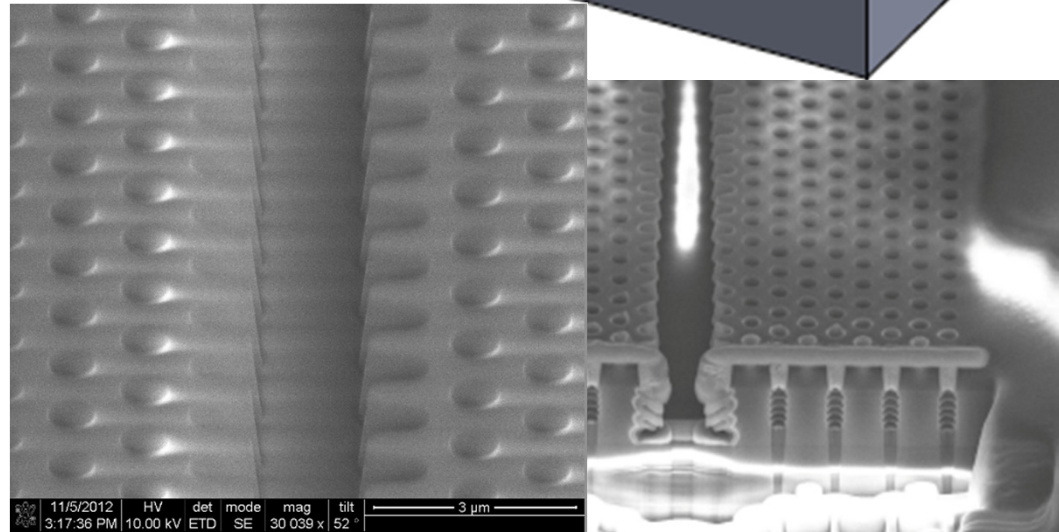

Single layer structure (2 um)
After Bosch process



Single layer testing at IRNWA

- Precision IRNWA for mode transmission

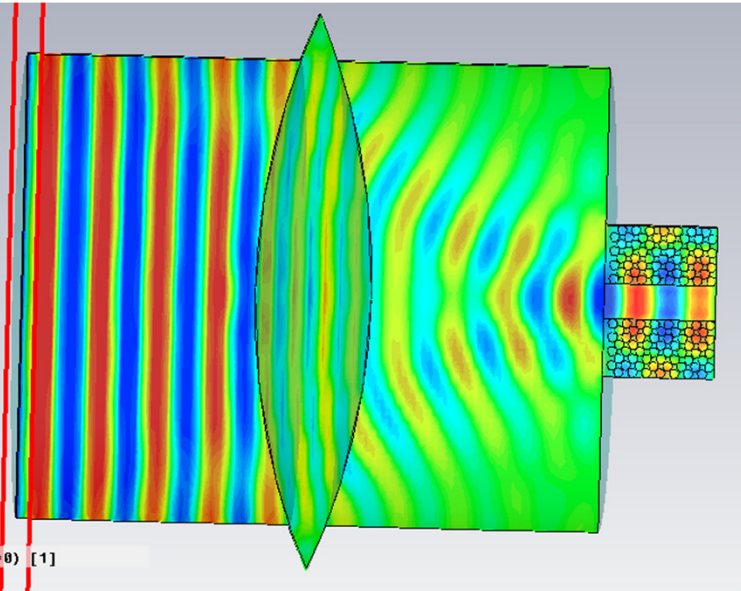

Simulation of coupling (CST)

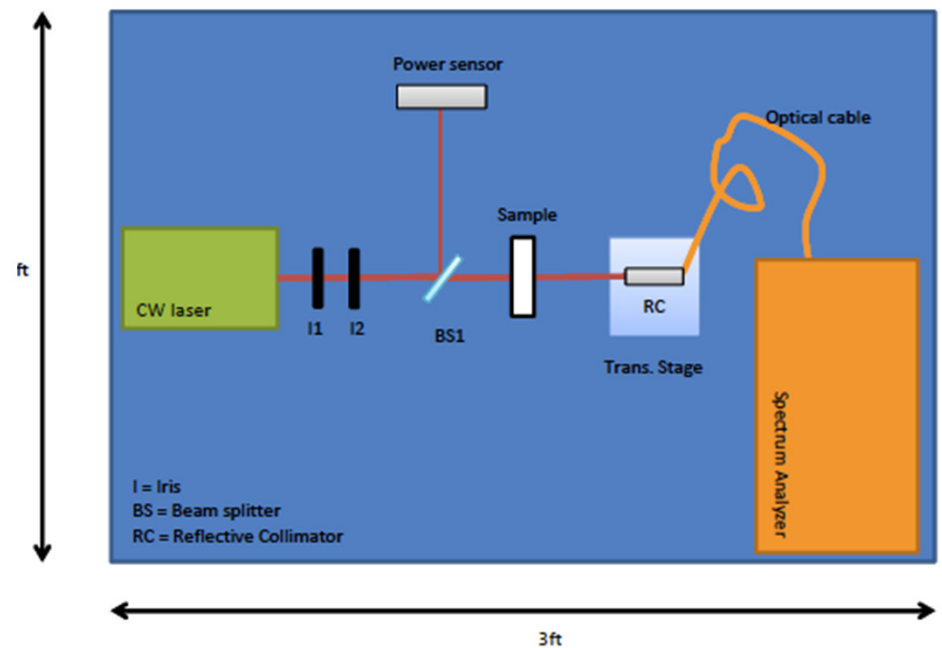

Single layer structure projection

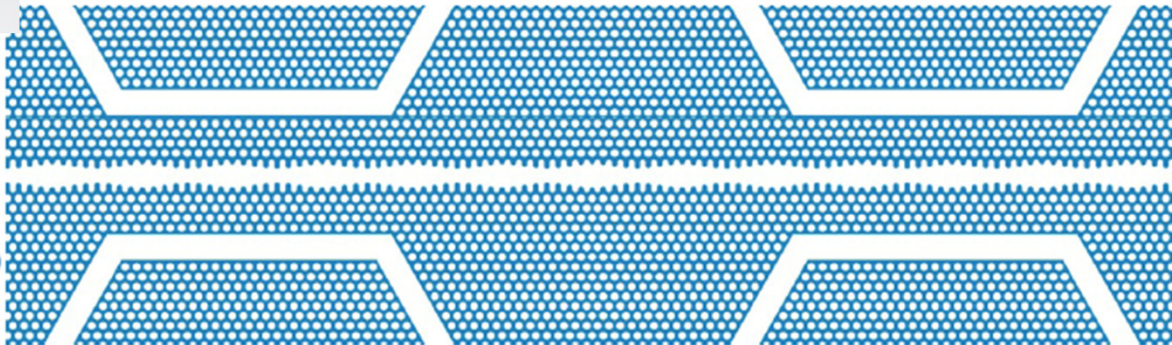

Stackable DLA structures

3-level alignable stack

Not full photonic control in x

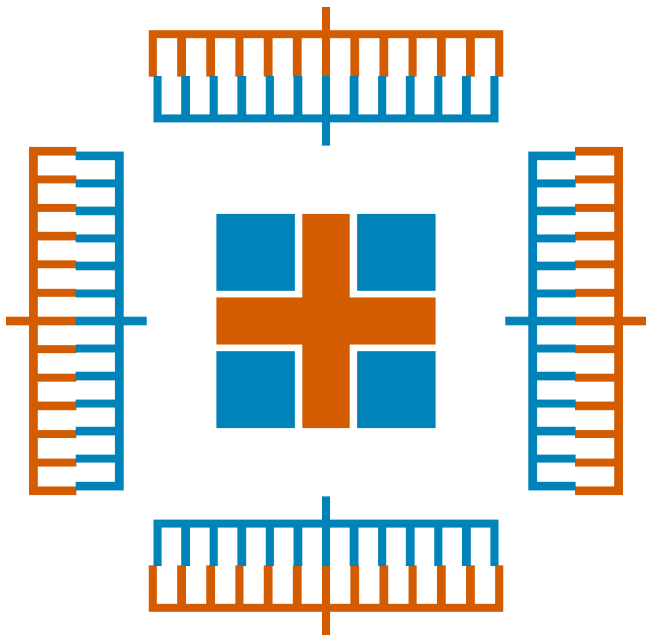

Closeup of alignment mark

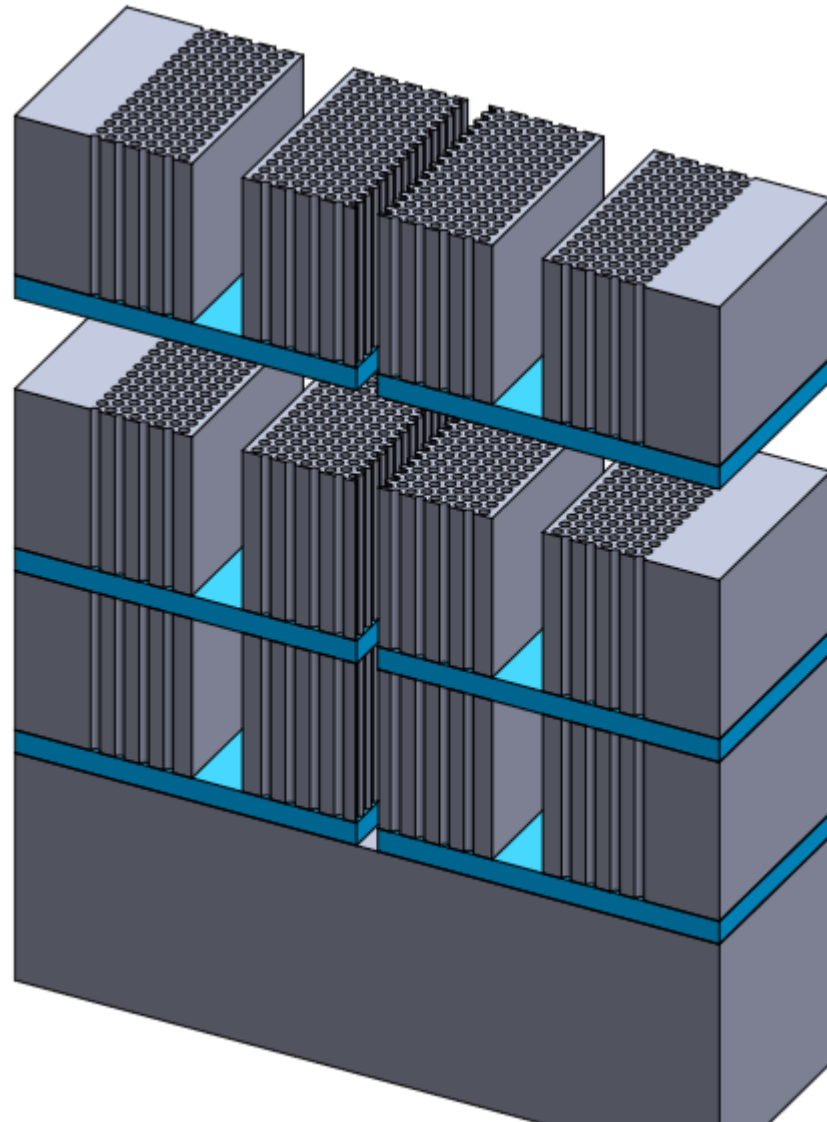

Thick, stackable layer fabrication plan

1) Raw wafer



2) Reactive Al/O₂ sputter

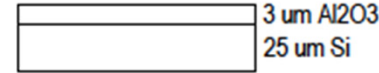

3) Flip wafer

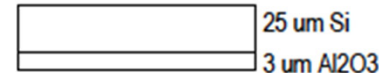

4) HTO

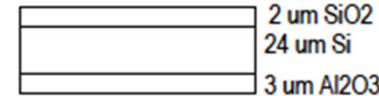

5) Spin coat

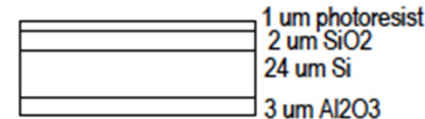

6) Expose 'photonic' mask

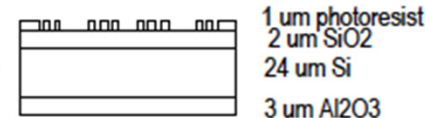

7) Dry etch hard mask and remove PR

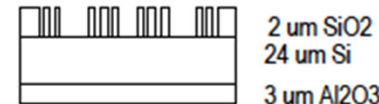

8) Deposit polysilicon

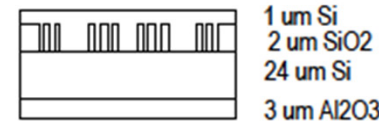

9) HTO



10) Spin coat

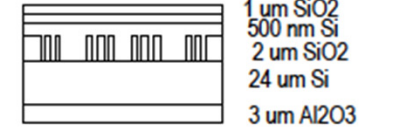

11) Expose 'beamline' mask



12) Dry etch hard mask and remove PR

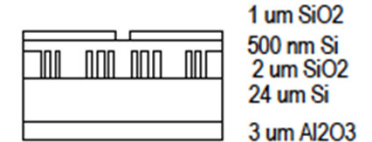

13) Bosch etch



14) Sapphire plasma etch



15) HF etch SiO₂

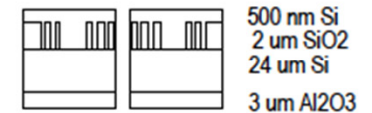

16) Deep Bosch etch



17) HF etch SiO₂ hard mask

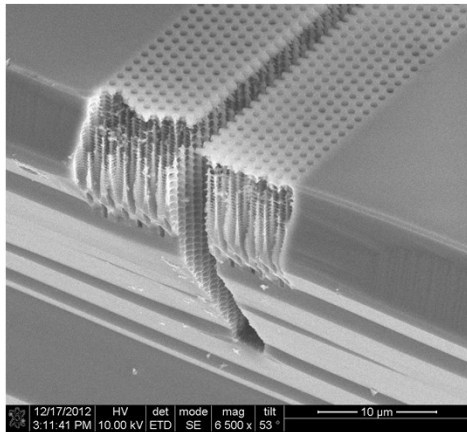

Ist attempt at DRIE



Returning to the monolithic dream...

- Macroporous Si may provide path
- Extremely high aspect ratios possible (400 demonstrated)
- Active development at UCLA

see, e.g. S. Ottow, *et al.*,
J. Electrochem. Soc. **143**
385 (1996).

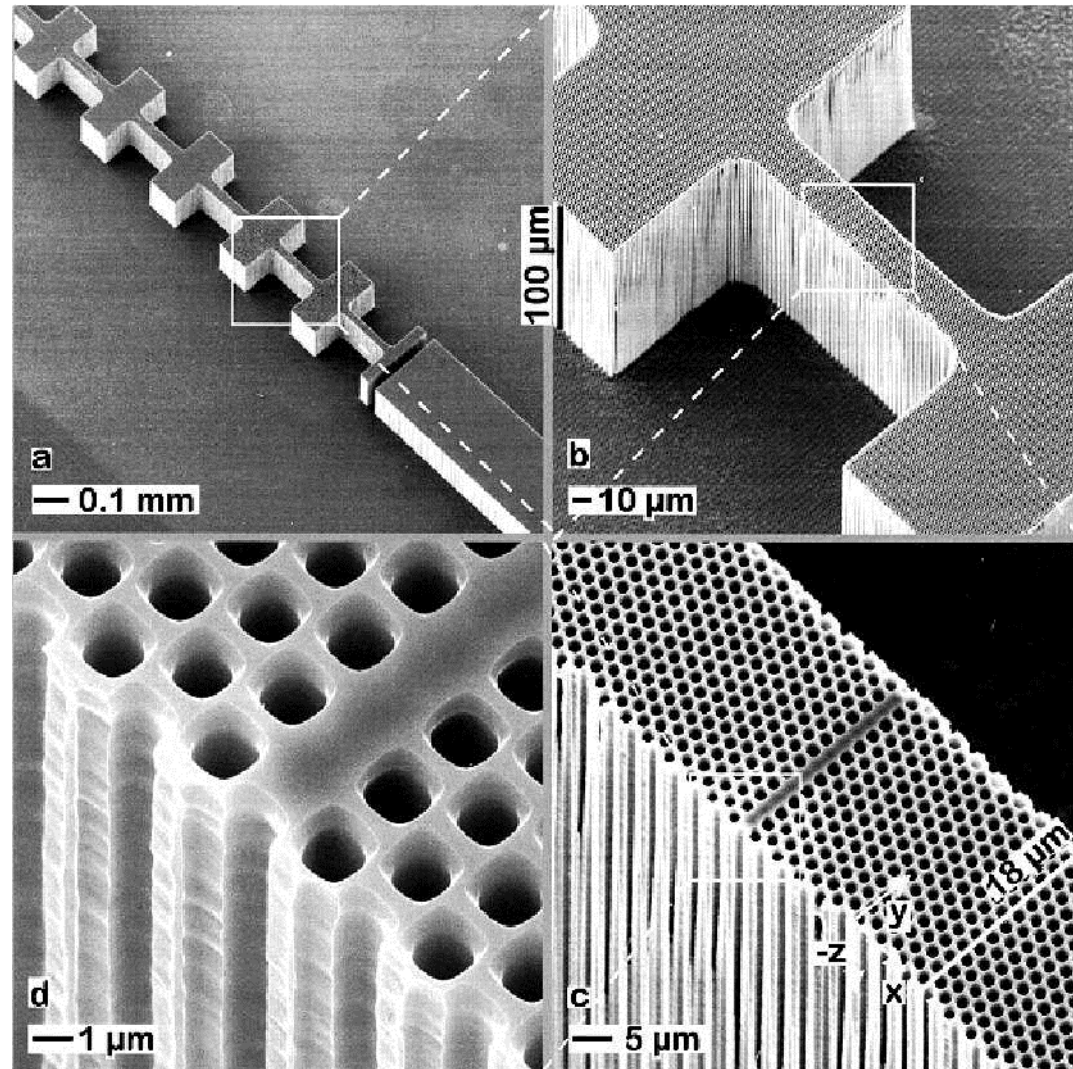

Electromagnetic Undulators: Approaches

All electromagnetic undulator for GALAXIE has two notable approaches:

- **An all-optical undulator**

- EM wave at 5 μm co-propagates with e-beam; stretch undulator wavelength to 100 μm .
- E and B field forces tend to cancel; the surface and bulk fields high compared to net equivalent deflecting field.
- Aperture in this device ~ 1 -2 times that of laser wavelength; extremely small, wakefield problems must be studied carefully.
- GALAXIE has implemented a Bragg type structure

- **THz structure with wave propagating opposed to e-beam.**

- With EM-wave propagating counter to beam, the undulator wavelength is $\sim 1/2$ free space wavelength. E and B forces *add*.
- To realize undulator we *invented* a new type of an RF cavity structure that supports a SW with very high field at center, low field near walls



Bragg Undulator Field Profile

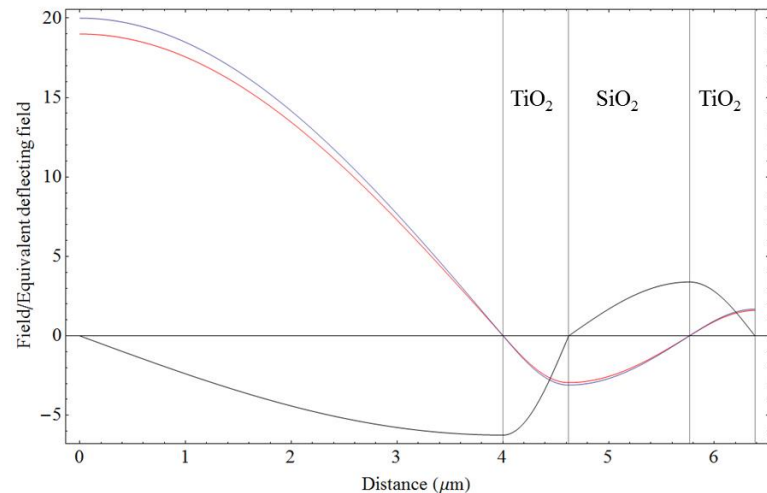
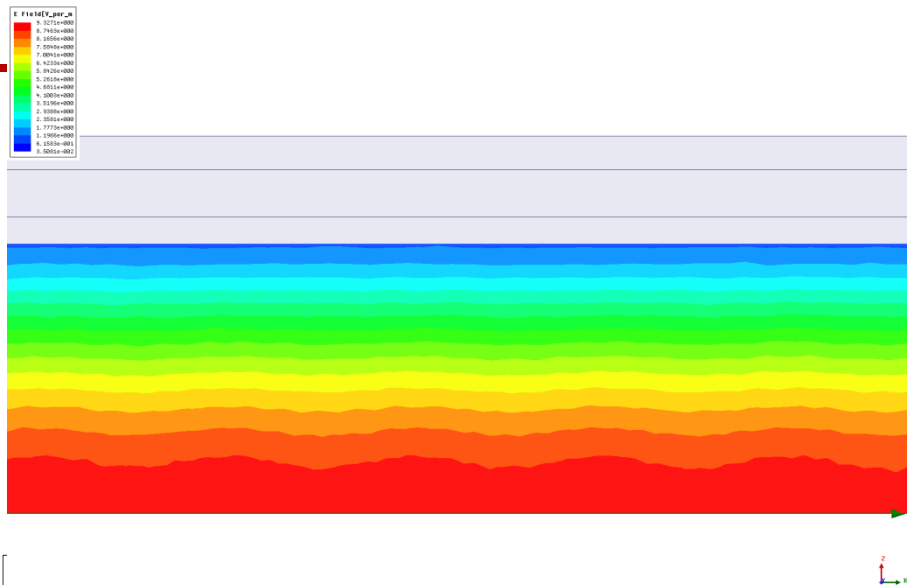

Structure realized, now undergoing testing
10 μm tests at BNL ATF in late summer



Incident Plane wave

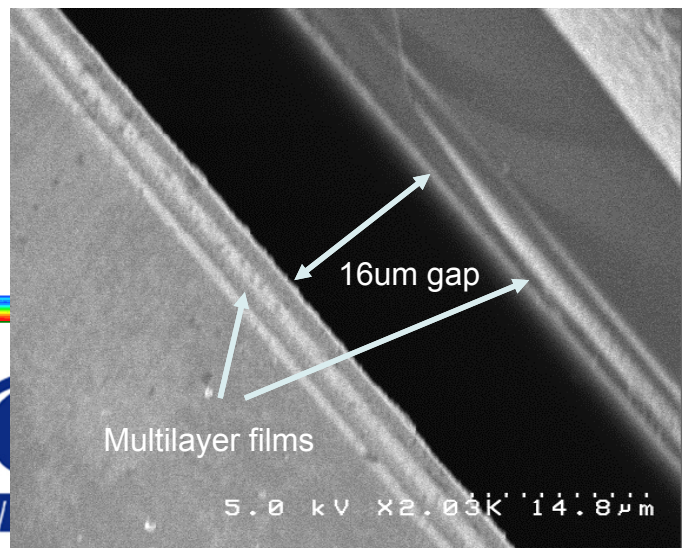

Scaled THz (microwave) Undulator Design

Two coupling ports 90° apart to excite two polarizations independently

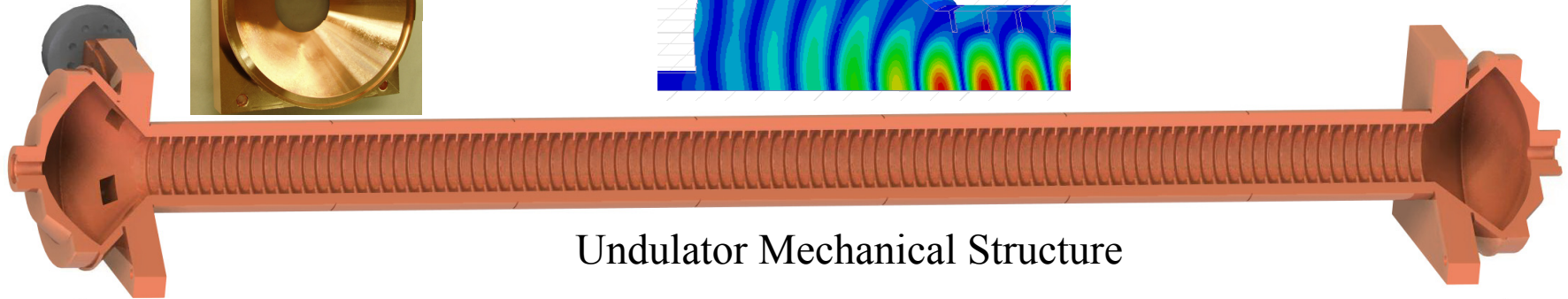
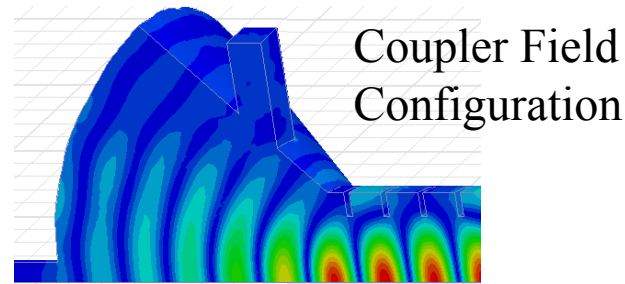
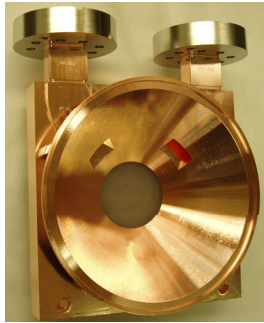

Undulator Mechanical Structure

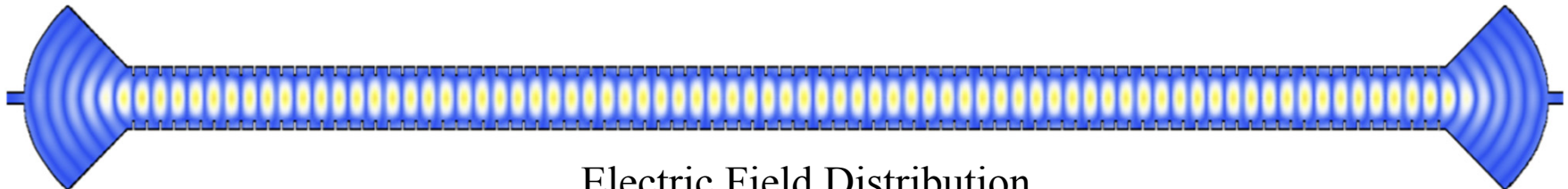

Electric Field Distribution

Corrugation Period= 0.4254λ
Inner Radius= 0.75λ
Outer radius= 1.01293λ
Corrugation Thickness= $\lambda/16$
Number of periods =98

$\lambda=2.624 \text{ cm}$
Undulator Wavelength= 1.393 cm
Power required (linearly polarized, $K=1$): 49 MW
 $Q_0=94,000$



Simulations and Cold Test Comparison

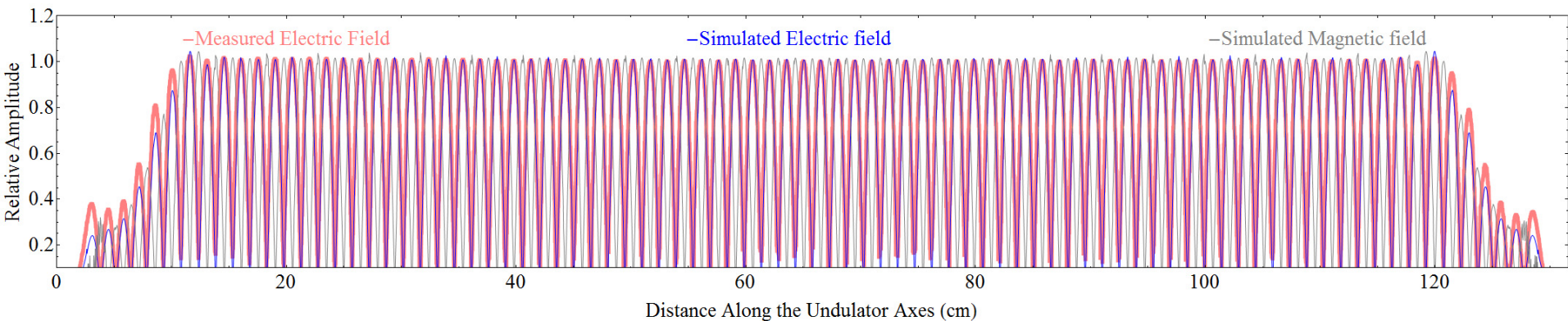
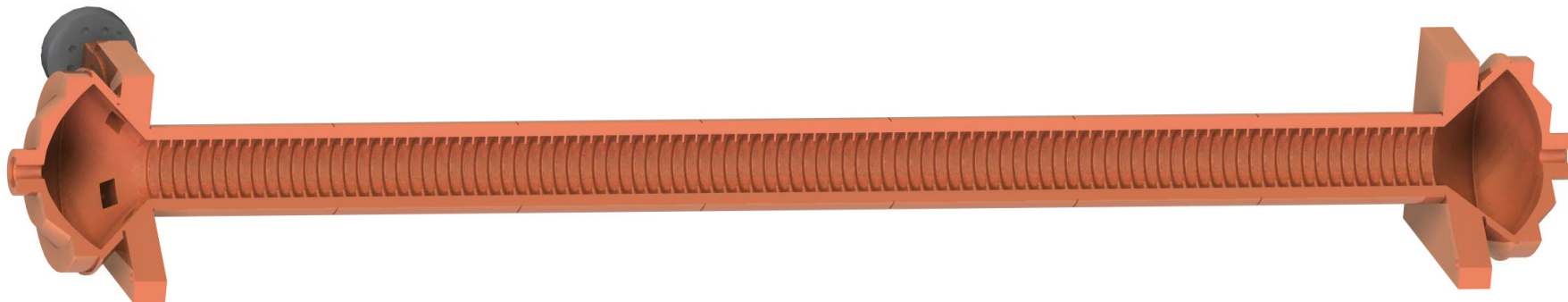

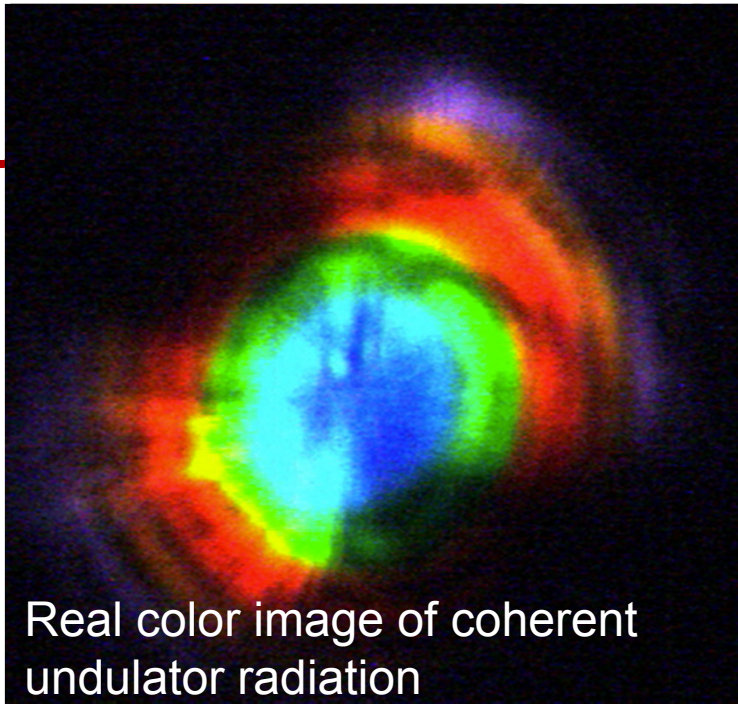

Real color image of coherent undulator radiation

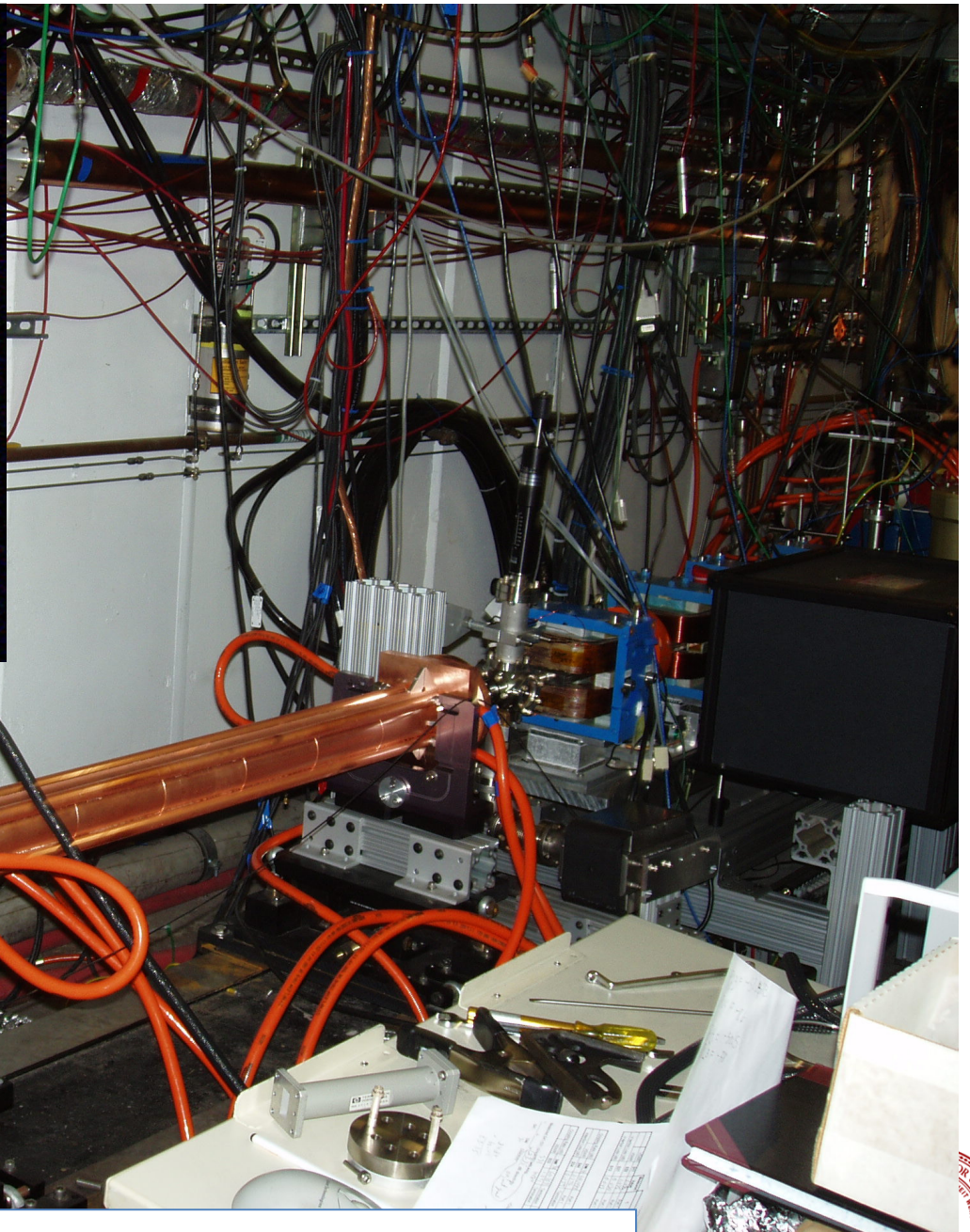

NLCTA installation/beam testing

Measurement of the undulator K

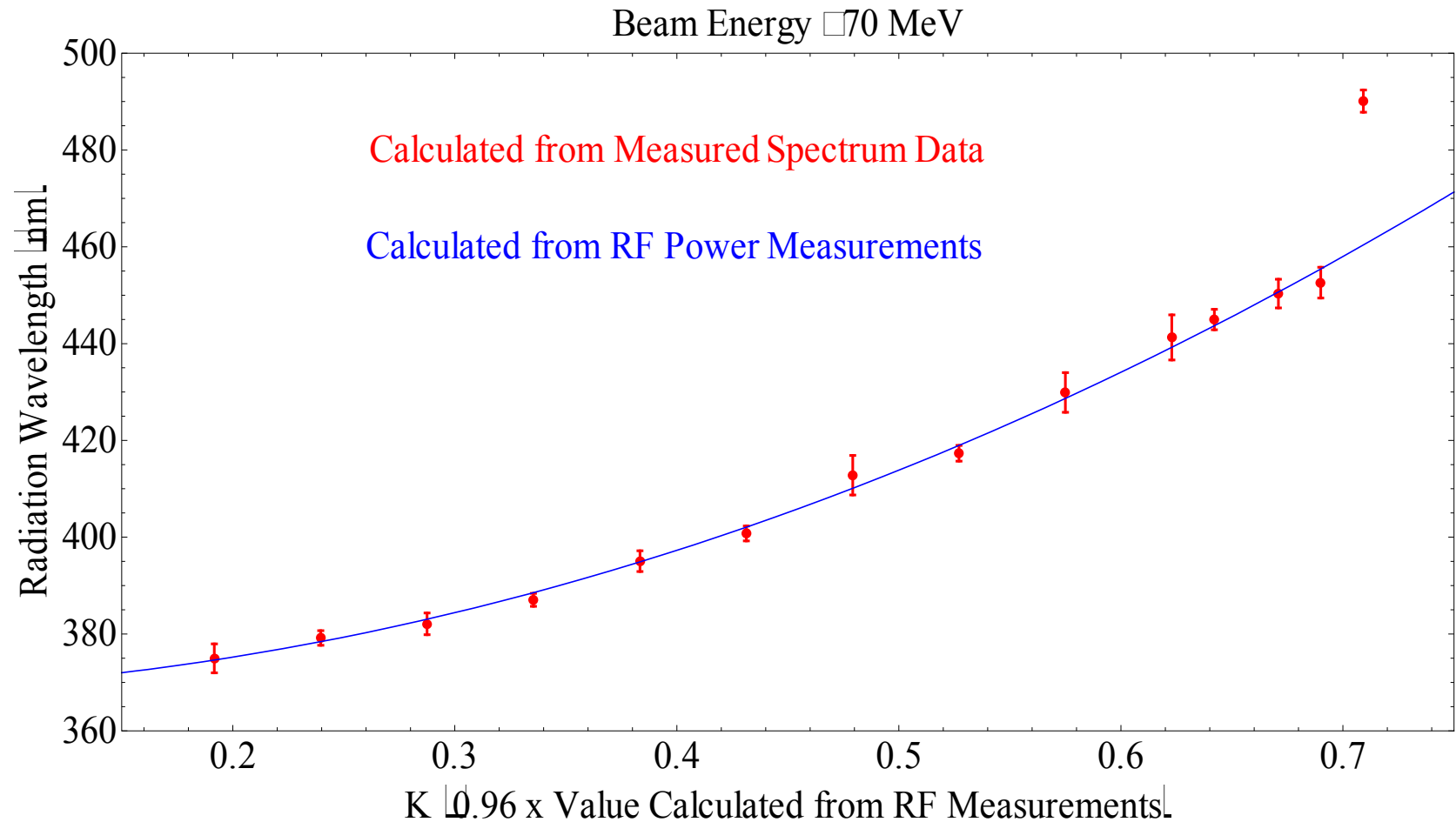

THz undulator challenge: source

- Possible solution: THz maser (taser?)

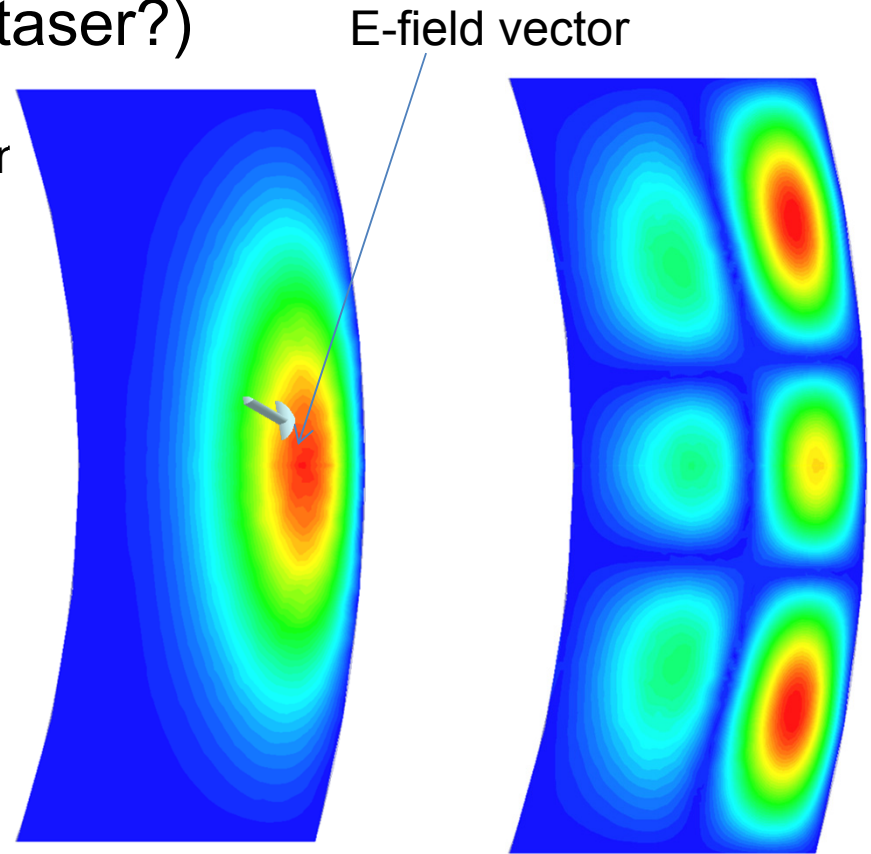
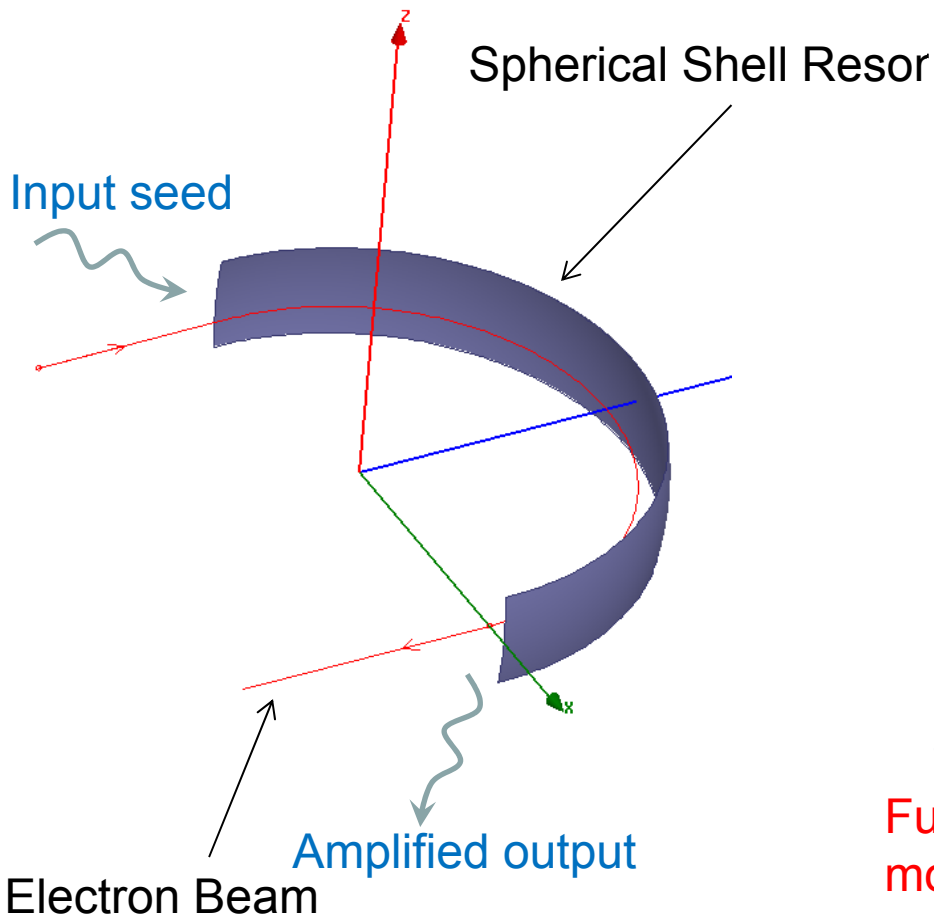

Fundamental mode has high Q

Higher order modes have lower Q;

$$Q_{\text{hom}}/Q_{\text{fundamental}} \sim 2 \times 10^{-2}$$

S. Tantawi (SLAC)



Alternative approach: MEMS Undulator

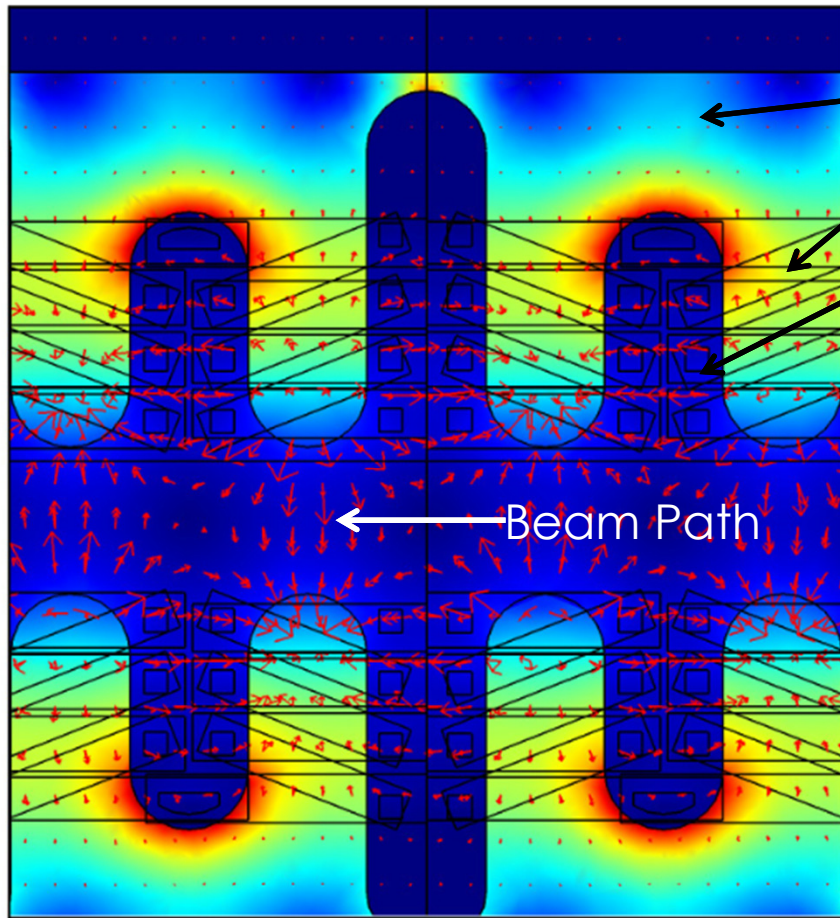

Yoke

Windings

Via

Beam Path

Candler group device

R. Candler group, UCLA EE

First test with visible light emission at Pegasus, next two months, then SLAC One-m long water window FEL possible

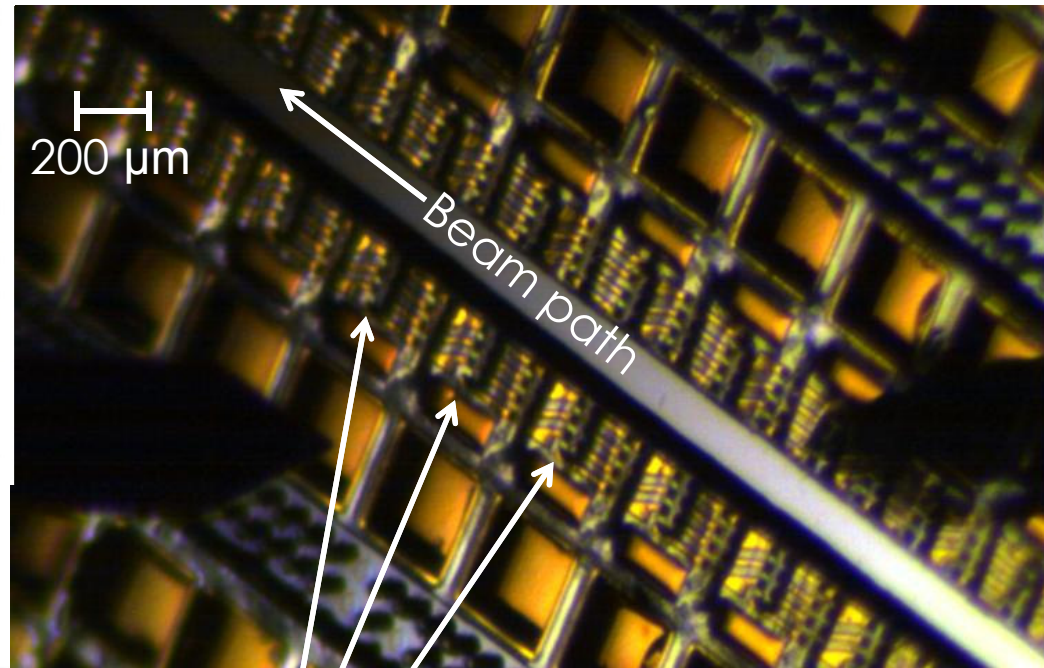

Electromagnets



Summary

- *Comprehensive approach to 5th generation light source*
- Sophisticated new design for DLA
- Advanced dynamics (transverse and longitudinal)
- Exploration of material breakdown limits
- Novel DLA fabrication approaches needed
- GV/m wakefield studies
- High power mid-IR laser development
- Next generation injector pursued
- New approaches to optics and beam measurement
- New class of undulators
- *Fascinating interconnected challenge set. Keep going!*

