

HIGH GRADIENT ROOM TEMPERATURE CAVITY DEVELOPMENT FOR 10 – 100 AMeV BEAMS*

Ali Almomani and Ulrich Ratzinger, IAP-Frankfurt University, Germany

Abstract

These linac activities are aimed to increase the accelerating field gradient. At IAP – Frankfurt, a CH – design was proposed for a compact ion accelerator. The effective accelerating field gradient is expected to reach more than 10 MV/m. Within a funded project, this cavity will be systematically developed towards a high gradient cavity. The availability of the GSI 3 MW klystron test stand will be very important for these investigations. The results will influence the rebuilt of the Unilac - Alvarez section, where the existing linac tunnel with 1 m thick concrete walls should house a powerful pulsed heavy ion linac, optimized for achieving the beam intensities specified for the GSI – FAIR project. The status of the cavity design will be presented.

INTRODUCTION

Conventional DTL’s are seriously limited in maximum field gain by thick walled drift tubes for housing focusing elements. This geometry causes extended parallel surfaces around the gaps loaded by high electric fields. The multipacting probabilities as well as the stored field energies are rather high at these cavities resulting in a reduced field gain.

On the other hand, it was demonstrated, that thin-walled drift tubes in combination with KONUS – beam dynamics allow to reach an effective field gain of around 10 MV/m at pulse lengths of 1 ms and at low beam energies already [1]. H – Mode cavities are very well suited in that case, as they concentrate the electric field on the drift tube structure very well. So, the stored field energy is reduced efficiently by a small outer drift tube diameter.

This effect is most pronounced in case of the Interdigital H – type (IH) – structure. In case of Crossbar H – mode (CH) – structures the stem structure makes a larger partial contribution to the total capacity, and therefore, the drift tube effect is not as pronounced but still significant.

The development of room temperature CH – cavities was described in [2] in more detail.

This paper is focusing on high field gain especially. This aspect is important for cases, where a compact linac for low duty applications is needed.

Originally, this cavity development was triggered by the post-acceleration of a laser – accelerated proton bunch [3-4].

Meanwhile the main aim of this work is to prepare for the rebuilt of the high energy section of the GSI – Unilac, which will in future serve as heavy ion injector for the FAIR project.

* This work is supported by HIC for FAIR and by BMBF: Contract number. 05P12RFRB9.

CH – CAVITY DESIGN

The new structure is designed as a 7 – gap structure with constant $\beta = 0.164$. The large end tubes will be filled by quadrupole lenses (see Figure 1).

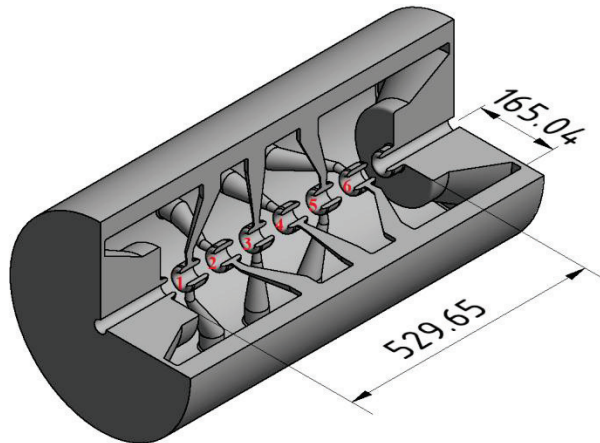

Figure 1: A 3D schematic view of the CH – cavity.

In the CH – structure, the current flows from the outer cylinder radially to the drift tubes along the stems in order to generate the axial electric acceleration field.

The stems are supporting the mechanical stability of the CH – structure; they carry the highest current density (Figure 2).

Because of that their design must be very robust and with efficient water cooling. On the other hand, close to the beam axis the stems have to be kept slim to reduce the capacitance between neighboured stems.

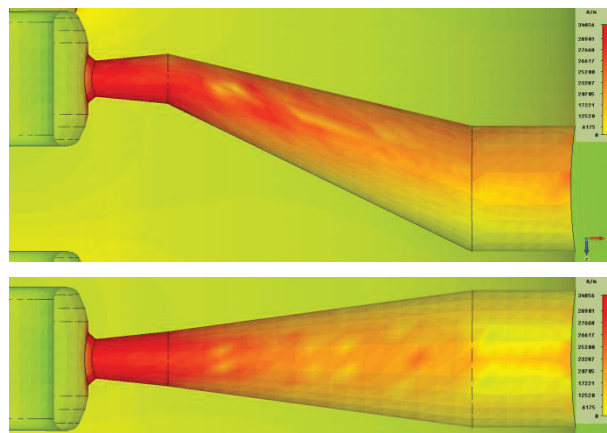

Figure 2: A detailed view on the surface current density flowing along the stems (top: stem 1 and bottom: stem 3). The stems are carrying the highest density near by the drift tubes due to the necessary low electric capacity design.

The on axis (path 1 in Figure 5) and by the aperture radius shifted (path 2 in Figure 5) electric field distribution as calculated with MWS is shown in Figure 3. The corresponding gap voltage distribution for this case is shown by Figure 4.

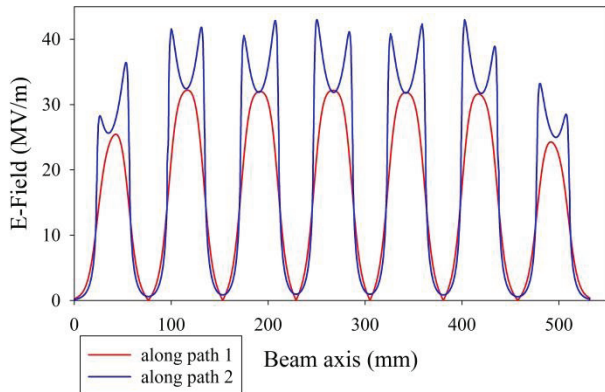

Figure 3: The axial electric field distribution as calculated by CST – MWS along the beam axis and along the aperture radius.

The electric field is roughly uniform along the central 5 gaps and is reduced in the end gaps. This gives the optimum effective shunt impedance values.

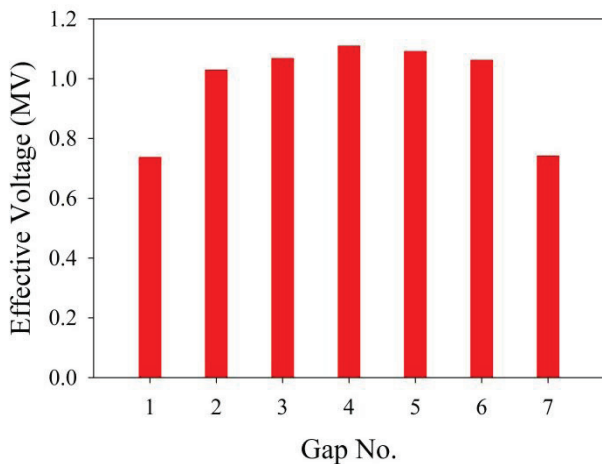

Figure 4: Effective gap voltage distribution from CST – MWS simulations.

The main characteristic parameters of this cavity are given in Table 1.

Table 1: The Main CH – Cavity Parameters for the High – Field Gradient Prototype

Number of Gaps	7
Frequency (MHz)	325.2
Voltage Gain (MV)	6
Eff. Accel. Length (mm)	529.65
Eff. Accel. Field (MV/m)	11.2
Power Loss (MW)	1.58
Q_0 – value	13500
Effective Shunt impedance (M Ω /m)	57.3
Beam Aperture (mm)	27

SURFACE ELECTRIC FIELD

Because of no internal focusing elements in this CH – DTL, the adaption of slim drift tubes is possible (see Figure 5). This behaviour of the drift tubes results in many interesting features like a very high sparking limit when compared with other structures like Alvarez DTL.

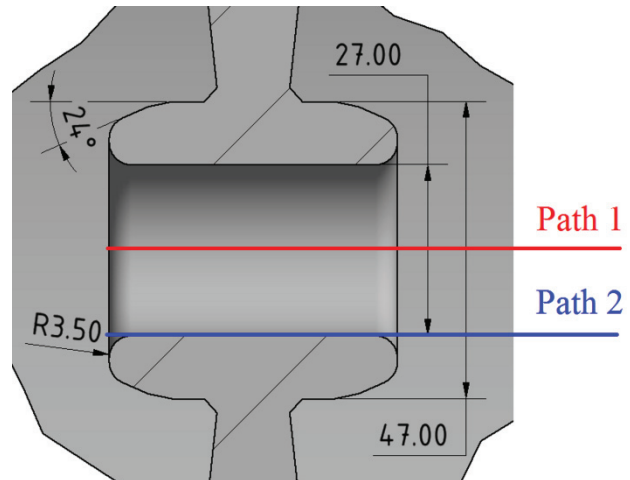

Figure 5: A cut of one of the drift tubes and the connection to the stems.

The maximum effective accelerating gradient for this cavity was designed to reach 11.2 MV/m. This corresponds to a 97 MV/m maximum surface electric field spot at the central drift tubes (see Figure 6). These maximum values appear very locally on the drift tube edges.

The ratio between these local field maxima on the drift tube surface and the maximum on axis gap field is about a factor 3.0.

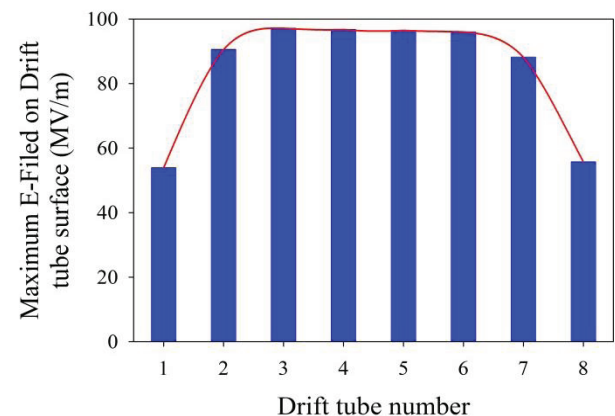

Figure 6: The maximum electric field values on the drift tube surfaces.

The hot spot maxima are defined by drift tubes facing the inclined stems. By an improved stem design, this effect was reduced.

In order to get realistic field surface values in the simulations, the drift tube edges are rounded carefully at the model geometry.

The electric and magnetic energy densities are shown in Figures 7 – 8.

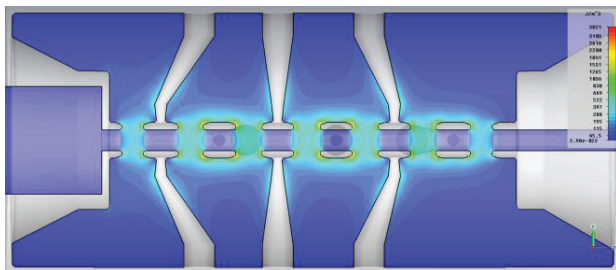

Figure 7: The electric energy density inside the cavity which is concentrated along the beam axis.

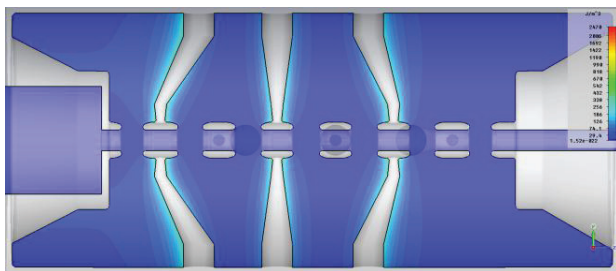

Figure 8: The magnetic energy density inside the cavity which reflects very well the surface current distribution as shown in Figure 3.

As can be seen in Figure 7, the electric energy density is localized along the drift tubes. One can see that drift tube surface fields have two azimuthal maxima in the plane of the neighbored stem: This is shown by Figure 9 in detail, where the surface field at a radius of 19.43 mm is shown around the circumference for the front end of drift tube no. 3. Two local maxima indicate the plane of the stem which carries the drift tube under consideration (no. 3 in our case).

SURFACE PREPARATION

The cylindrical tank and the drift tube structure will be built from stainless steel. The welding concept will follow the CH – cavity development for the FAIR proton linac [5]. One challenge is the final copper plating of such a structure. First results have been quite promising [2].

The geometric aspects for successful copper plating were implemented in the design.

A central topic is to find out the differences between high lustre copper plating as practiced at GSI successfully since many decades and the lustre less copper plating as applied successfully at some facilities recently.

Main aspect in our case is the high voltage capability.

CONCLSION AND OUTLOOK

There are many pulsed beam linac projects aiming on compact designs. One class of facilities are medical hospitals where available space is quite restricted

Another class might become ADS – facilities, where pulsed operation can be tolerated.

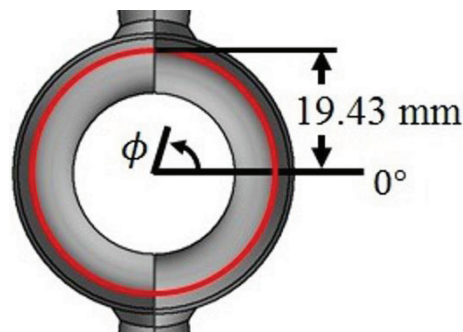
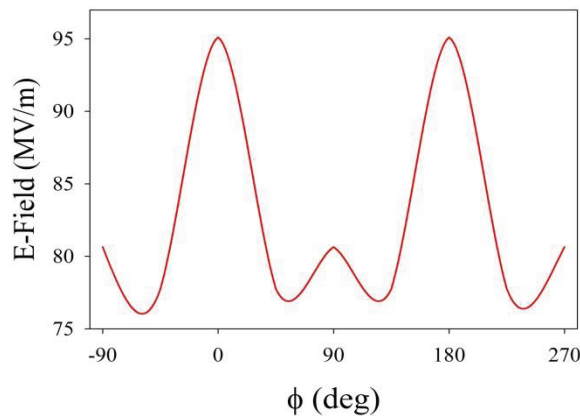

Figure 9: Electric surface field versus the azimuth angle ϕ at a radius of 19.43 mm along the front end of drift tube no. 3 (top). The maximum values are in the plane of the neighbored stems. The path is shown red (below).

A new generation of 1 MW high power amplifiers based on power transistors and H- type cavities may allow to significantly reducing cost and size of future ion linacs in the energy range up to about 100 AMeV.

The high acceleration rate provides the longitudinal focusing forces needed for high current operation.

Detailed investigations as for example on the two different types of copper layers can be performed on this cavity and by using the GSI high power 325 MHz test stand driven by a 3 MW Toshiba klystron.

ACKNOWLEDGMENT

We like to thank our GSI linac colleagues, and especially W. Barth, L. Groening, B. Schlitt, G. Clemente who inspire us by their project requests and who will open the chance to perform high power rf tests.

REFERENCES

- [1] J. Broere et al., Proc. LINAC98, Chicago, USA p. 771 (1998).
- [2] G. Clemente et al., Phys. Rev. Special Topics – Accelerator and Beams **14**, 110101 (2011).
- [3] A. Almomani et al., Phys.Rev. Special Topics – Accelerator and Beams **15**, 051302 (2012).
- [4] A. Almomani et al., Proc. IPAC11, San Sebastián, Spain, WEPS033 (2011).
- [5] R. Brodhage et al., to be published in Proc. IPAC13, Shanghai, China, THPWO015 (2013).