

THE DESIGN AND COMMISSIONING OF THE RF SYSTEM FOR CYCIAE-14 CYCLOTRON

Zhiguo Yin, Bin Ji, Yu Lei, Pengzhan Li, Guofang Song, Chuan Wang, Tianjue Zhang, Zhenlu Zhao, CIAE, Beijing, China

Abstract

The CYCIAE-14 project was launched by BRIF division of CIAE in year 2010, to build a 14MeV compact proton cyclotron for medical applications. The beam energy, intensity as well as other parameters of the machine is selected in such a way, so that the cyclotron-based production of technetium-99m (Tc-99m) can be evaluated. The commission of this cyclotron was successfully finished in the middle of year 2012, with extracted beam energy equals to 14.6MeV and intensity high than 100uA. The RF system of the CYCIAE-14 cyclotron includes a set of lambda by four cavities (connected with each other under central region), a 20kW triode amplifier and related 1 inch rigid line power transmission system. It also includes a set of Low Level RF control circuits, which takes advantages of modern digital technologies such as DSP and DDS to achieve close-loop regulation of the accelerating voltage and frequency. The design of this RF system starts from the middle of year 2010. Most of the equipments are manufactured and shipped to site before the end of year 2011. The installation and commission of this RF system was started in the beginning of year 2012 and finished about 3 months later, the measured voltage stability is better than 0.1%. The design and difficulties in the commission was reviewed in this paper, on particular, the instability introduced by transmission line taped with high Q load as well as the problems caused by RF leakage during the commission was also analyzed.

INTRODUCTION

The modern PET/CT system might be divided into two major parts, the clinical scanner and the cyclotron, the latter provides an FDG production service to support the former. As in these years, the local medical demands for the PET/CT system raised rapidly in china, a medical cyclotron project has been launched by BRIF division of CIAE in year 2010 [1]. The construction cycle for this project is limited to be two years, and it has been successfully finished in time.

For small medical cyclotron, most of the design adopts internal ion source for both simplicity and efficiency considerations. It should be admitted that in most cases it suits the case, and can provide 50uA to 100uA beam without major limitations. While for the CYCIAE-14 cyclotron, aiming at higher beam intensity, e.g. 400uA of proton beam, the system takes advantage of external ion source and axial injection and spiral inflector design. One of the design goals is to evaluate the cyclotron-based production of technetium-99m (Tc-99m) by using reaction of $^{100}\text{Mo}(p, 2n)^{99\text{m}}\text{Tc}$ [2].

DESIGN OF THE RF SYSTEM

The RF system of CYCIAE-14 cyclotron includes a set of $\lambda/4$ cavities, a 20kW triode amplifier and a set of low level controls, as shown in Fig.1. The two cavities are connected internally with each other under central region.

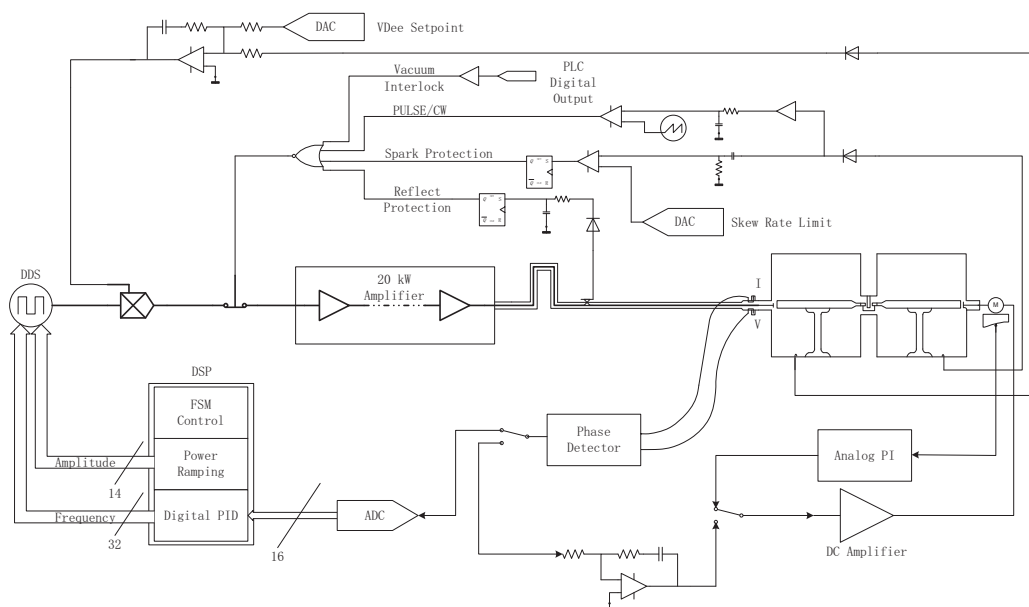

Figure 1: Block Diagram of the CYCIAE-14 RF System

Hence, they share one set of power coupling and tuning capacitor, which both located semantically in the outer radius of the middle plane of the cyclotron. The 20kW triode amplifier consists of four stages amplification. The first two stages are solid stages, while the rest are using vacuum tube technology. The system also includes a set of Low Level RF control circuits, which takes advantages of modern digital technologies such as DSP and DDS to achieve close-loop regulation of the accelerating voltage and frequency. Other important functions such as automatic start-up, interlock as well as fast spark recover are also integrated in the Low Level control. The main parameters for the RF system of CYCIAE-14 are listed in table 1.

Table 1: Parameters of the RF system

Frequency Range	72.85MHz~73.05MHz
Operating mode	Fixed Frequency, CW
Acc. Voltage	40kV
Voltage Stability	$\Delta U/U \leq \pm 5 \times 10^{-4}$
Tuning Error	$ \phi_z \leq 5^\circ$

Cavity Design

One of the change compare to the design of CRM cyclotron RF cavity is that the new design adopts capacitive loaded $\lambda/4$ resonator, hence the stem diameter are enlarged if using the same Dee shape. On one hand this strategy gives better result for the rigidity of the resonator, while the drawback is that the unsymmetrical structure gives bigger RF leakage. By digital simulations using CST software, the TEM mode of the resonator is determined and a preliminary structure of the cavity is given for mechanical design.

The detailed structure of the cavity system can be divided into several major parts, e.g. the Dee plate, the stem, the liner and a set of separated liner cooling plate. The liners are fabricated using 1.5mm OFHC copper, where the joint take advantage of TIG welding. The Dee plates are firstly coarse machined, and then cooling circuits were soldered onto it by using Certanium-34C. Afterward, it was fine machine to give best result of structural accuracy. For the stem, spiral cooling circuits are adopted, consequently electron beam welding are used for seal the water joins. Skews are used to fix the RF liner to the cooling plate after the installation, which is a compromise design result considering the installation complexity, the cooling and the mechanical rigidity.

After surface treatment and cleaning, the measurement indicate the installed cavity has a resonance at 72.93MHz, while the loaded quality factor and shunt impedance are 2200 and 80k Ω respectively.

Amplifier and Transmission Line System

The Amplifier is manufactured by Amplifier System Inc. located in California, USA. It might be classified as an AB class linear RF power amplifier. The final stage

and inter-media stage are using triode tubes, while the driven stages take advantage of solid stage technologies. The total efficient of the amplifier is 72%.

During the commissioning, there's several modification to the original ASI design. These includes the following, the material of the cooling plate of the driven stage is changed from aluminium to copper, for the reason that the plate also act as one of the electrode of the MOSFET. And in the mean time, the copper oxides are electronically conductive. A constant power filament circuit taken advantage of a serious inductor on the primary of the filament transformer was added to give the tube more gentle soft start when powering from cold state. Related filament current metering was also added for both the tube stage as well, to evaluate the aging of the tube. Cooling interlocks are tripled to enhance the safety, as one major water cooling failure of the cyclotron has caused problems during the commissioning.

Low Level RF Control

The Low Level RF Control is designed to have four states. The S1 states is pulsing mode, which takes advantage of fast skew rate of the pulse to penetrate the mutipacting levels. The S2 state is the frequency tracing state, in which DDS frequency word are changed in a close-loop manner to adapt to the initial frequency change of the cavity system. The S3 state is the traditional capacitive tuning state, which will automatically start once the df/dt of the cavity system in S2 drop below a preset value. The S4 state is a fail-safe state, is deigned to handle the case that the tuning capacitor is not big enough to cover the thermal frequency change in the whole run time. The experience in the commissioning shows that for the CYCIAE-14 cyclotron the S4 is never triggered in all the time, and if using S1 and S2 only, the total frequency drift is within 0.1MHz.

RF CONDITIONING

The RF conditioning is a process that using RF power to lower the secondary electrons yields of the RF surfaces for low power operations, and to decrease the field emitted electron load and sparking rate to an acceptable level in high power operations.

For the first goal, during the commissioning of the CYCIAE-14 cyclotron RF system, long interval low duty cycle pulse was used to identify each mutipacting level to have estimation of the boundary. The conditioning practices on this RF system indicates that, in compact cyclotron, the presents of the fringe magnet filed inside the Dee structure may increasing the difficulty of feeding power into the cavity. This could be even more difficult when using diffusion pump for the main vacuum system. In such a case, there's not too much choice but to take advantage the high efficiency of CW wave conditioning. After the Dee voltage has been successfully established, the conditioning are continued by decreasing power level time to time while maintain the cavity tuned in the process. This is done by an automated system developed by the BRIF division of CIAE. For high power

conditioning, CW mode is not preferred, as it may cause big reflection and may deposit too much energy on the critical RF component, e.g. the coupling window. Therefore, the pulse mode are adopted for high power, until the Dee voltage reaches 120% of the design value. The chance of sparking decreased rapidly at the beginning of the high power conditioning, and finally goes to zero after conditioned several times.

STARTUP SEQUENCE

After the conditioning, the next movement is to start the system using the Low Level RF control. The start up sequence of the system is shown in Fig.2.

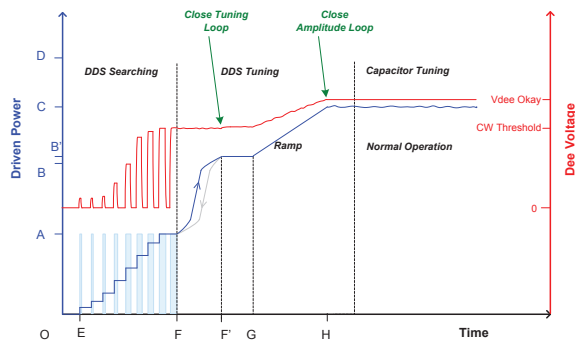

Figure 2: RF system start-up sequence.

Considering the fact that the cold cavity has higher resonance frequency for CYCIAE-14 cyclotron, the resonance searching begins at lower frequency and stepping toward higher frequency, as shown by E→F process in Fig.1. The automated system will increase duty cycle bigger and bigger as the searching frequency approach the cavity resonance frequency. When the duty cycle is bigger than 50%, it will go to CW mode in a relative short time, as shown by the F→F' process in Fig.1. Afterward the tuning circuits begin to maintain resonant frequency tracking by means of detect the detuning angle and regulating the DDS frequency word. At this stage the driven power is kept the same as it was when the system first goes into CW mode. After the frequency change rate decreased below 0.5 KHz/Sec, the system will initiate a power ramping (to 105% of required) and close the amplitude loop afterward, as shown by the G→H. The capacitor tuning will begin as soon as the df/dt changes its sign.

OTHER ISSUES

High Power Instability

This kind of instability is introduced by transmission line taped with a high Q load; this will form an impedance peak in the anode tank circuits, increasing gain in undesired frequency. One kind of the instability is near the work frequency, and would be quiet dangerous if left untreated. The other kind is far from base frequency but near high orders instead. The two type of high power instability has appeared in previous work of BRIF

division, and has been studied extensively before, therefore here only gives the length adjusting result of the transmission line for CYCIAE-14 cyclotron, as shown in Fig.3. Related information can be found elsewhere [3][4].

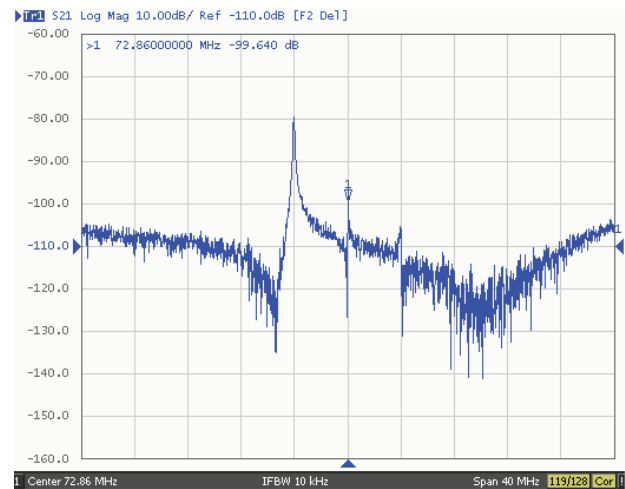

Figure 3: Transmission line length adjustment result

RF Leakage

In the commissioning, the adjacent valley once was lightening by plasma discharge. After investigation, two major reasons for this are determined, one is the RF leakage to that area and the other is that there was a local vacuum leakage just beneath. Also some electron bombardment trace on the HV connector of inflector indicated that there also exists certain amount of RF leakage in such area. This issue was solved by adding a shielding plate to break the symmetry of the structure.

ACKNOWLEDGMENT

One of the authors Zhiguo Yin would like thanks to Dr. Ken Fong from TRIUMF Lab. of Canada for the helpful discussions about the conditioning and start-up Logics.

REFERENCES

- [1] Tianjue Zhang, Yinlong Lu, Zhiguo Yin, et al Overall Design of CYCIAE-14, a 14MeV PET Cyclotron, Nuclear Instruments and Methods in Physics Research B, Volume 269, Issue 24, p. 2950-2954.
- [2] A Celler, X Hou, F B'ernard and T Ruth, Theoretical modeling of yields for proton-induced reactions on natural and enriched molybdenum targets, Phys. Med. Biol. 56 (2011) 5469-5484.
- [3] Zhiguo Yin, Kai Fei, Guofang Song, et al. AMPLIFIER TEST STAND FOR THE CRM CYCLOTRON, Proceedings of CYCLOTRONS 2010, Lanzhou, China
- [4] YIN Zhi-guo, LI Peng-zhan, ZHAO Zhen-lu, et al. High Order Mode Dumping of the 100 kW RF Amplifier, Annual Report of China Institute of Atomic Energy 2010.