



Fermi National Accelerator Laboratory

# Summary of Fermilab's Recycler Electron Cooler Operation and Studies

L. R. Prost, A. Shemyakin

May 22, 2012

IPAC'12

- ❖ Introduction
  - ❖ Cooling performance
    - Optimization
  - ❖ Operation
    - Limiting factors
-

# Tevatron luminosity and antiprotons

- ✓ The Tevatron luminosity is almost linear with respect to the total **number of antiprotons** available for Tevatron stores

Average initial luminosity as a function of the number of antiprotons injected into the Main Injector. Shown are the stores in 2011.

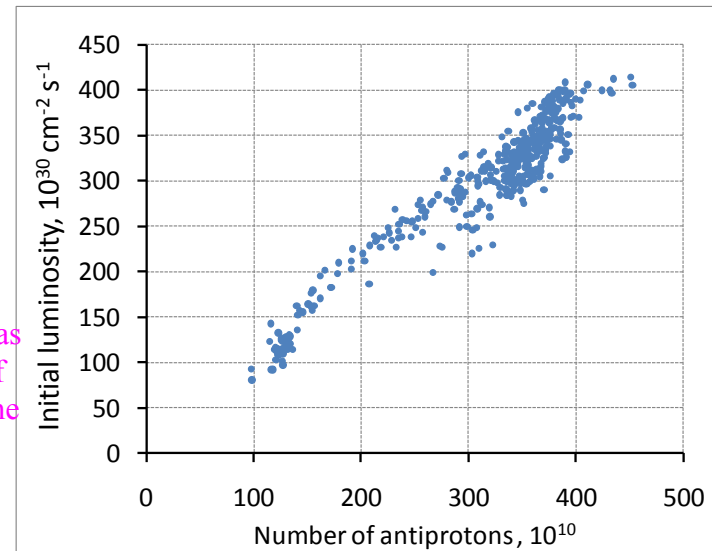

- ✓ Antiproton production was the bottleneck for luminosity production

- Electron cooling effectively removed this limitation and was the central component of the Tevatron Run II success.

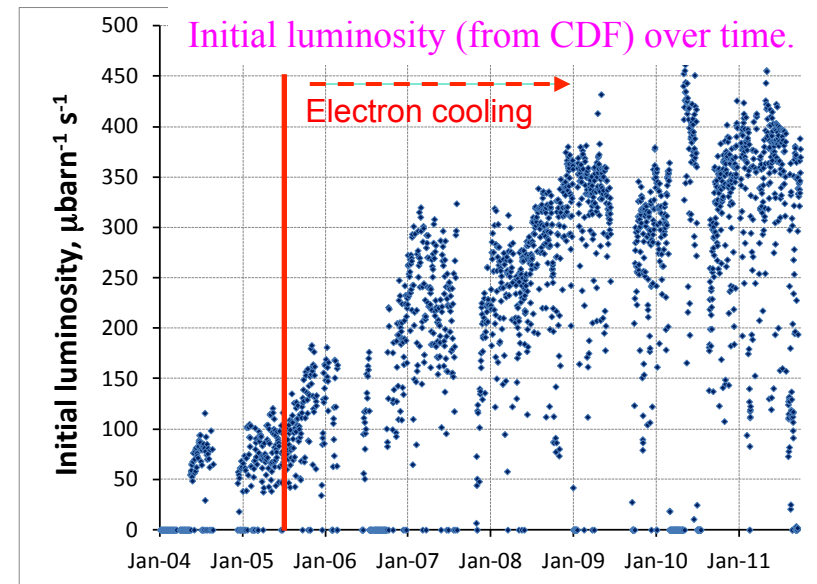

# Challenges for implementing relativistic electron cooling

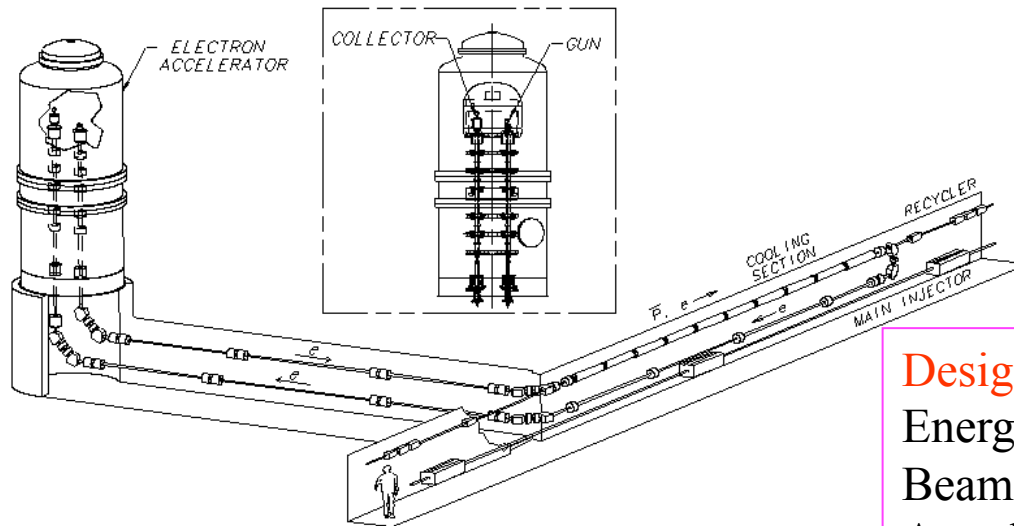

RR = Recycler Ring

## Design parameters of the RR ECool

Energy	4.3 MeV
Beam current (DC)	0.5 Amps
Angular spread	0.2 mrad
Effective energy spread	300 eV

- High electron beam power:
  - $4 \text{ MeV} \times 0.5 \text{ A} = 2 \text{ MW DC}$ 
    - Energy recovery scheme is a must
    - Very low beam losses are required
    - High voltage discharges need to be avoided
- Beam quality:
  - Transverse electron beam temperature (in the rest frame) should be comparable to the cathode temperature  $\sim 1400\text{K}$ 
    - Only a factor of  $\sim 10$  increase is allowed

# Cooler in the Recycler Ring

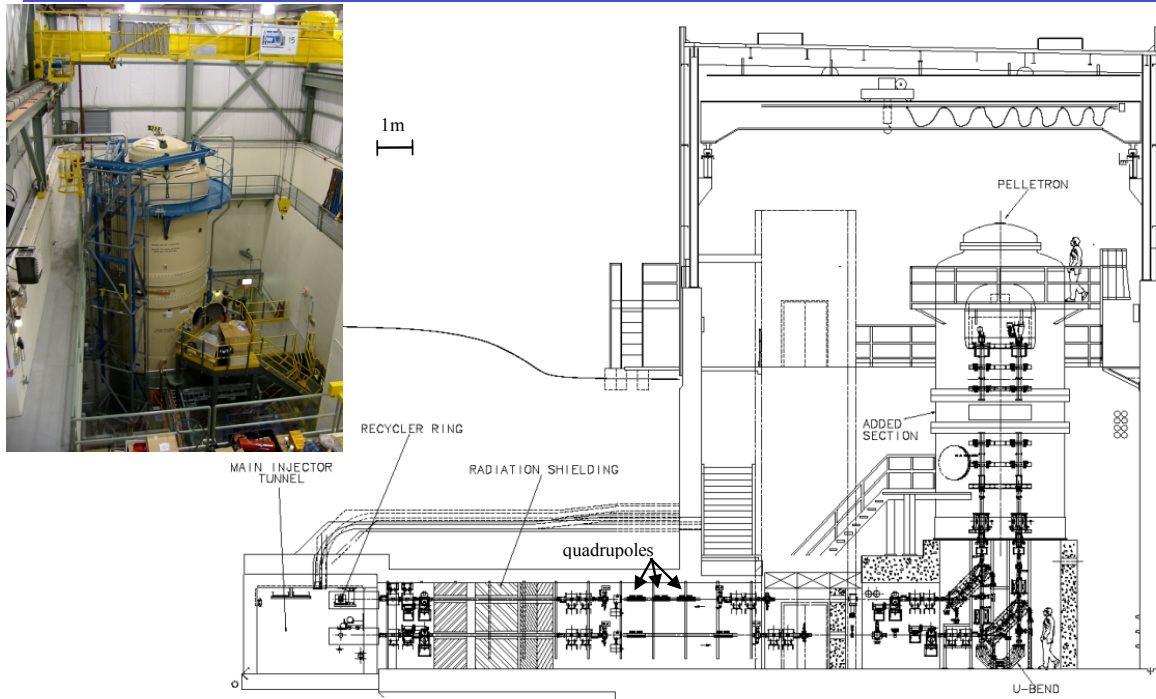

- February, 2005-  
Beginning of  
commissioning
- July 9, 2005 –  
First indication of the  
cooling force
- September 30, 2011 -  
End of Run II  
⇒ Cooler no longer  
needed

The Pelletron and beam “supply” and “transfer” lines

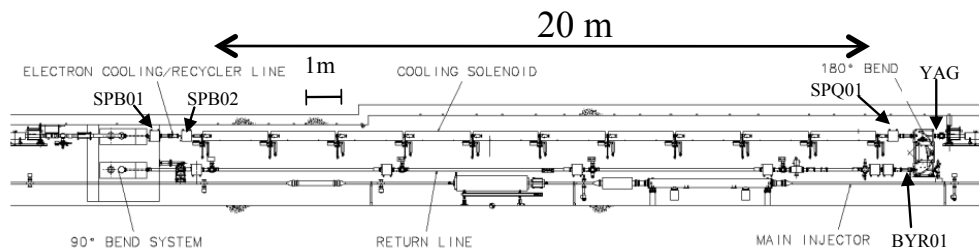

Portion of the Main Injector tunnel containing the cooling section and the “return” line.



---

# Cooling performance

## Non-magnetized cooling force

- The data were fitted to the classical formula neglecting magnetic field and assuming constant characteristics across the beam

$$\vec{F}_b(\vec{V}_p) = -\frac{4\pi e^4 n_{be}}{m_e} \eta \int L_c \frac{f_e(\vec{v}_e)}{(\vec{V}_p - \vec{v}_e)^2} \frac{\vec{V}_p - \vec{v}_e}{|\vec{V}_p - \vec{v}_e|} d^3v_e$$

$n_e$  - electron density in the beam rest frame  
 $m_e$  - electron mass  
 $V_e$  - the velocity of the particle  
 $\eta$  = (cooling section length)/(ring circumference)  
 $L_c$  - Coulomb logarithm

Impact parameters

$$\rho_{min} \sim 7 \times 10^{-7} \text{ mm} \ll \rho_{Larmor} \sim 0.15 \text{ mm} < r_{beam} \sim 2 \text{ mm}$$

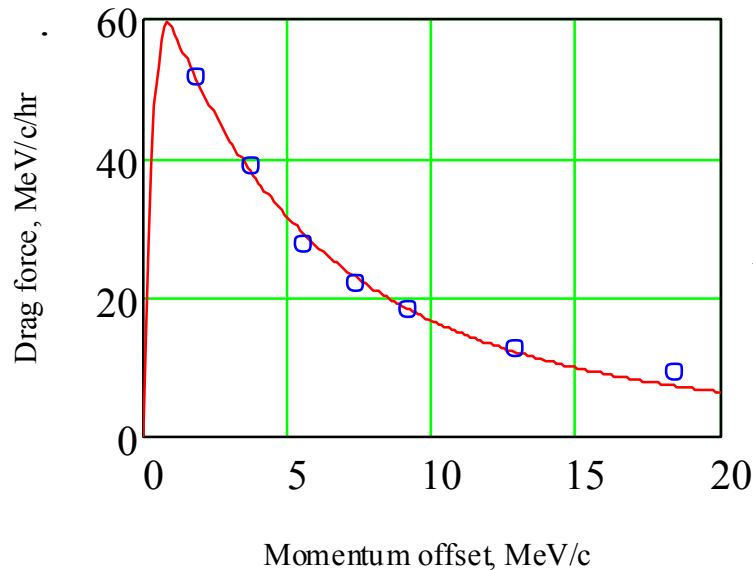

Drag rate as a function of momentum offset.  
 $I_e=0.1\text{A}$ , focusing is optimized for ion clearing, 100 Hz.  
 The circle is data, and the solid line is a calculation with  
 $\theta_e=80\mu\text{rad}$ ,  $\delta W_e=200\text{eV}$ ,  $L_c=9$ . January 4, 2011.

$\theta_e$  - electron angle,  $\delta W_e$  - energy spread

# Drag rate measurements

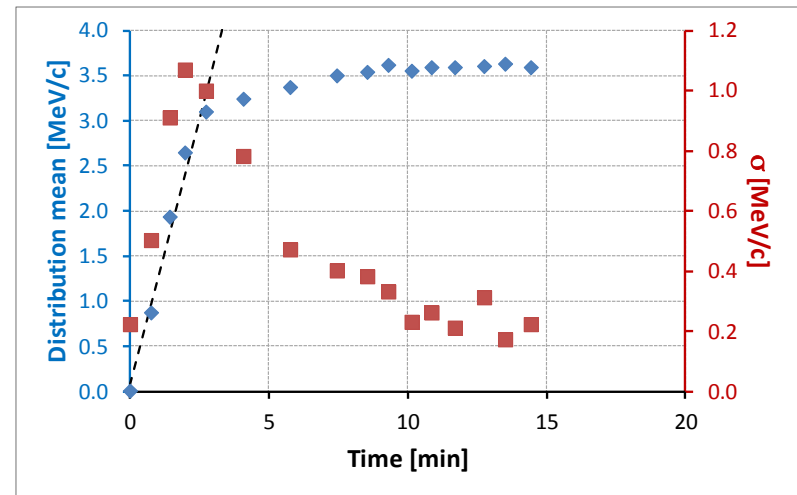
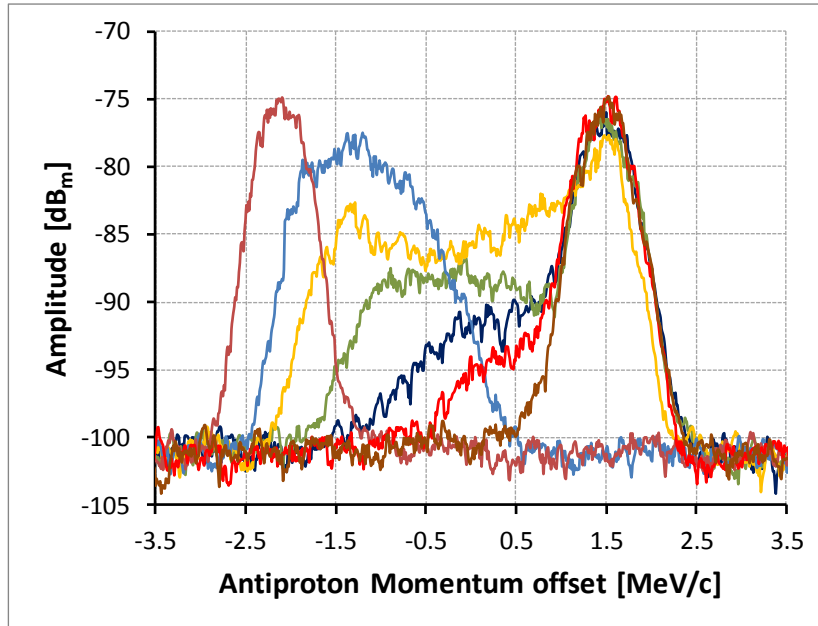

Corresponding evolution of the mean and rms values of the momentum distribution. The drag rate is 71 (MeV/c)/hr (Not a standard measurement)

Evolution of the antiproton momentum distribution recorded by a Schottky monitor after a 1.9 keV jump of the electron energy.

$I_e = 0.5A$  with ion clearing at 100 Hz. The time between the first and the last traces is 7 min.

January 2, 2011.

- Drag rate  $\approx$  Cooling force
- Works only for ‘not-too-high’ cooling force
  - Practical limit seems to be  $\sim 80$  MeV/c per hour
- The “pencil” antiproton beam can probe the electron beam at various offsets
  - In equilibrium, rms antiproton beam radius  $\sim 0.4$  mm

## Drag rate vs. Longitudinal cooling force

---

- Drag rate  $\equiv$  Longitudinal cooling force averaged over all antiprotons
    - Drag rate  $\approx$  Cooling force for ‘pencil’ antiproton beam
      - Small momentum spread
      - Small transverse emittance
    - Drag rate  $\neq$  Cooling force when electron beam properties not uniform over antiproton beam cross section
      - Accentuated when antiproton emittance not *small enough*
  - Difficulties to control transverse emittance
    - Scatter of the drag rates measured
    - Underestimate *true* cooling force
  - Solutions
    - Keep stochastic cooling on
    - Scrape antiproton beam down to the limit at which a reasonable resolution of the Schottky detector remains ( $N_p \sim 1 \times 10^{10}$ )
    - Apply strongest cooling between measurements
    - Decreased electron angles spread across the beam
-



## Drag rate vs. Longitudinal cooling force (cont')

- 'Reconstruct' cooling force taking into account the drag rate dependence on the electron beam radial position

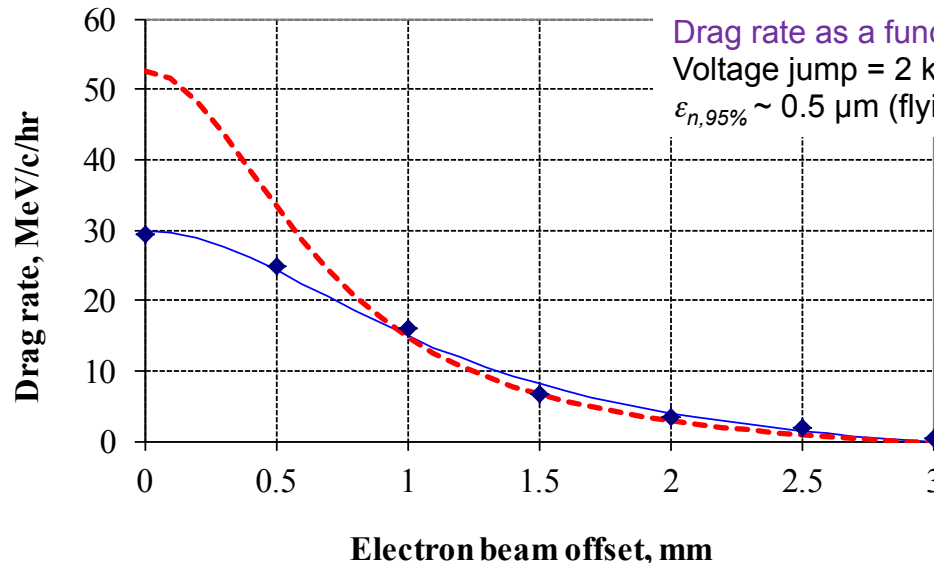

- Stochastic cooling on
- Strongest cooling between measurements
- Much lower electron angles spread across the beam

Blue curves: semi-empirical fit ( $\propto j_e / \theta_e^2$ )  
Red curves: reconstructed cooling force

Drag rate as a function of the electron beam offset  
Voltage jump = 2 kV,  $I_e = 0.3$  A,  $N_p = 1.3 \cdot 10^{10}$ ,  
 $\epsilon_{n,95\%} < 0.3 \mu\text{m}$  (flying wire) (12/10 data)

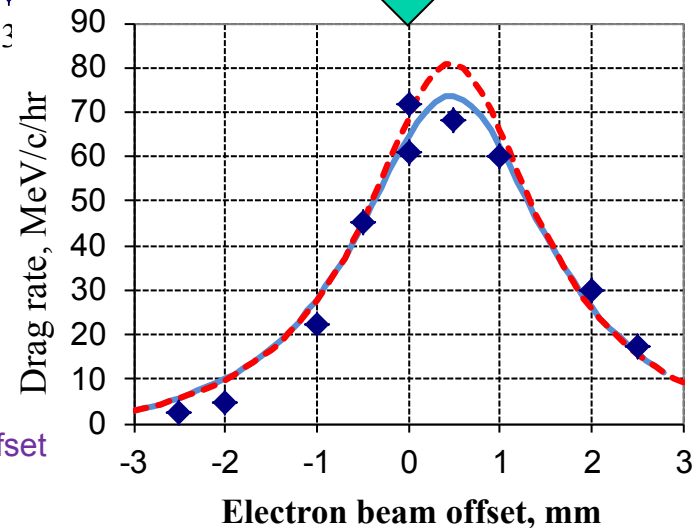

## Drag rate as a function of the beam current history

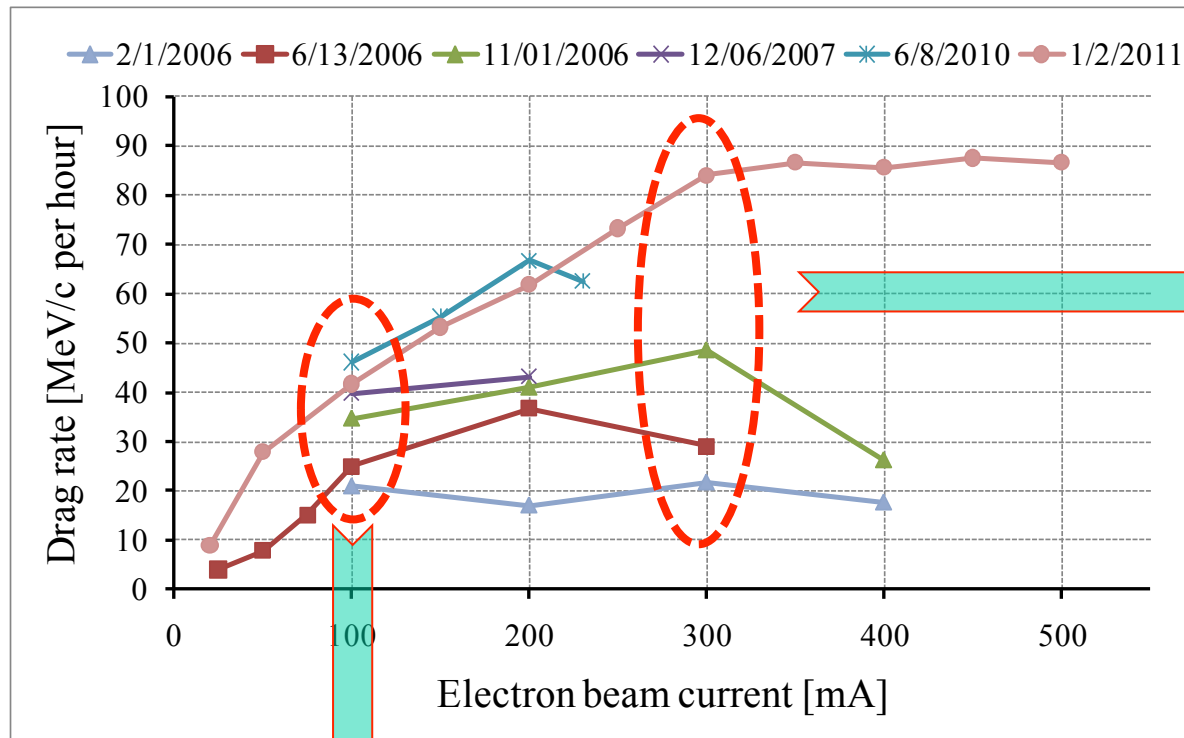

- At higher beam currents, the main improvement came from **ion clearing**
- Tuning was made mainly at  $I_e = 0.3\text{A}$

- At low beam currents, main improvements came from
  - Alignments of the field in the cooling section
  - Adjustment of quadrupole focusing
- All adjustments were made at  $I_e = 0.1\text{A}$

## Ions effect & Cooling with ion clearing

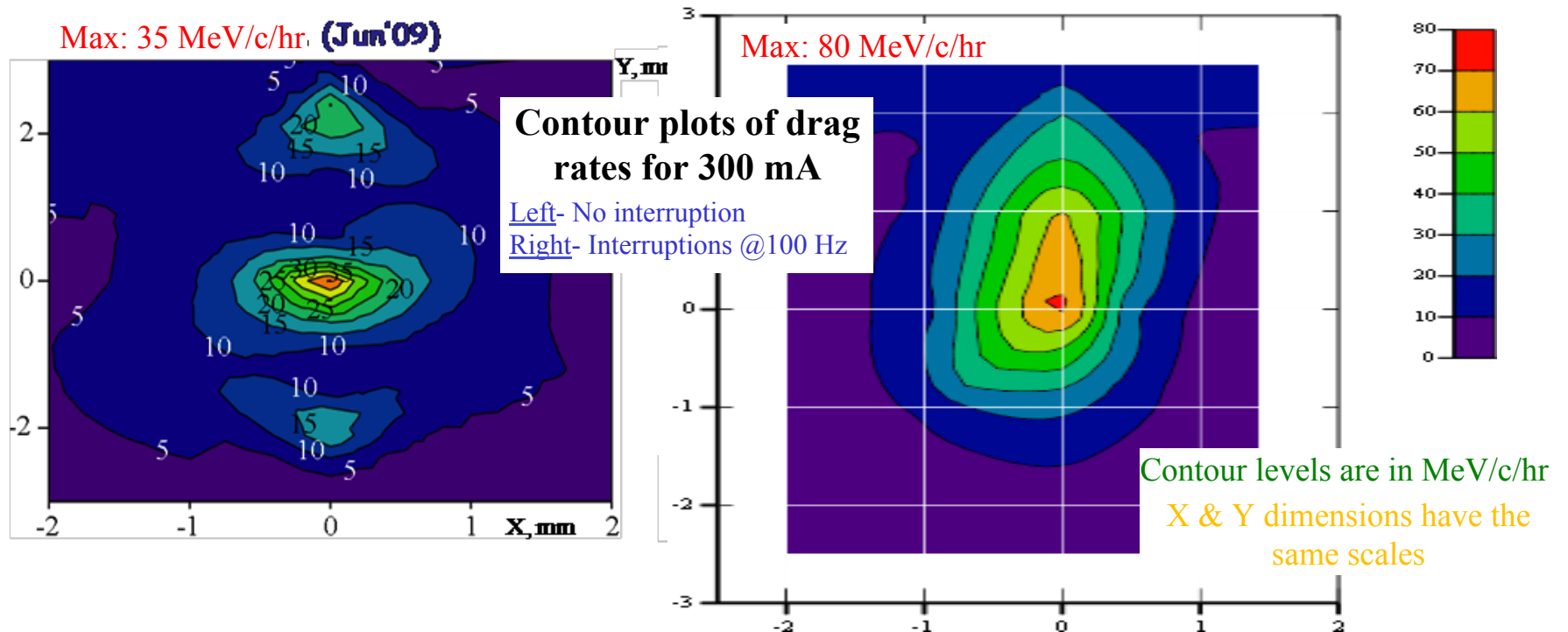

- Left plot: Three narrow areas of good cooling
  - *Hypothesis*: the reason is a highly non-linear focusing effect of ions
  - *Remedy*: clear ions by **interrupting the electron current** for a microsecond
    - In the beam electric field, the ions gain a high transverse velocity ( $W_{\perp} \sim 10$  eV) to reach the wall in  $\sim 1$   $\mu$ s after turning the beam off.
- Right plot: Beam interruptions @ 100 Hz i.e. ion clearing mode

# Quadrupole focusing adjustment

- Tuned quadrupoles based on the *drag rate* measurements (off-axis)
  - Maximizing the drag rate for each of 6 quadrupoles
- Cooling rate used as a numerical characterization of the actual effectiveness of cooling for operational conditions
  - Difference between time derivative of rms momentum (or transverse emittance) with the cooling system on and off

**Cooling rates increased by ~1.5 times longitudinally and by ~2 times transversely (at  $I_e = 0.1A$ )**

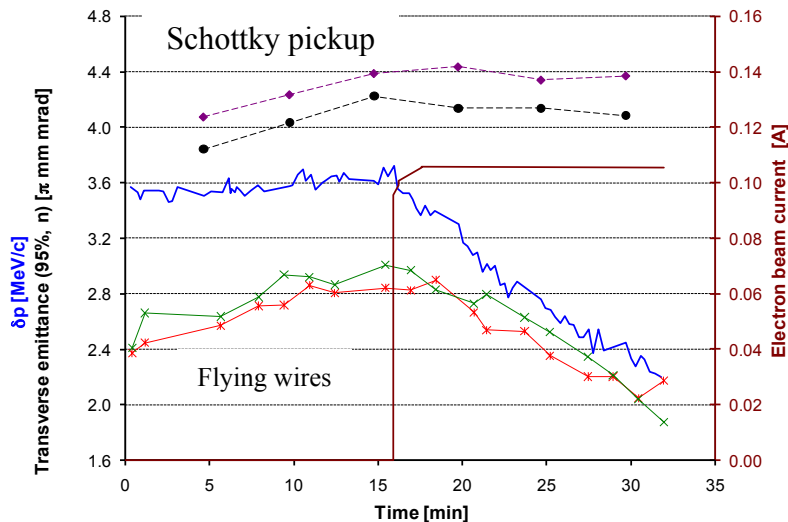

Typical cooling rate measurement  
 $I_e \sim 0.1A$ , beam on axis

Longitudinal cooling rates at various vertical offsets of the electron beam **before** (set 2) and **after** (set 1) adjustments of quadrupoles.  $I_e \sim 0.1A$ .

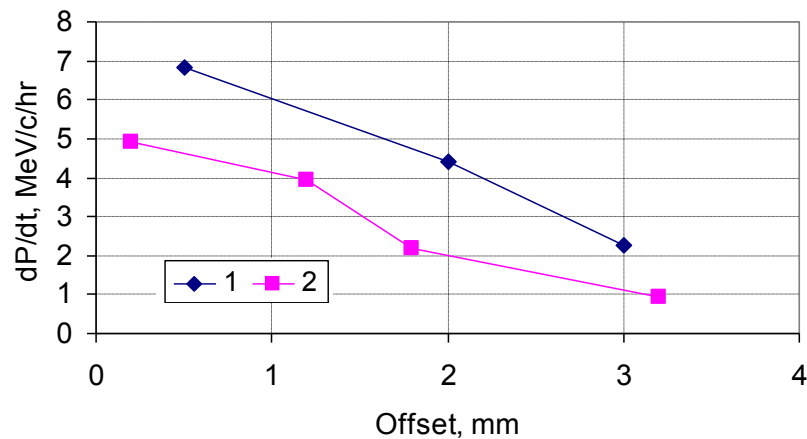

## Cooling force vs. cooling rate

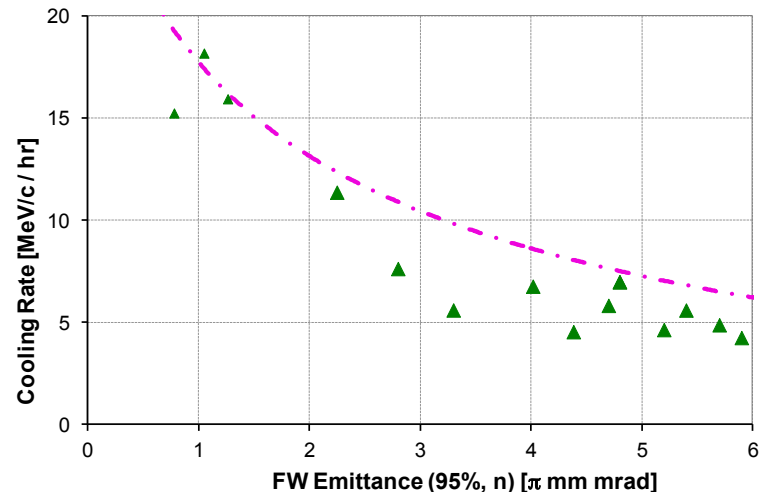
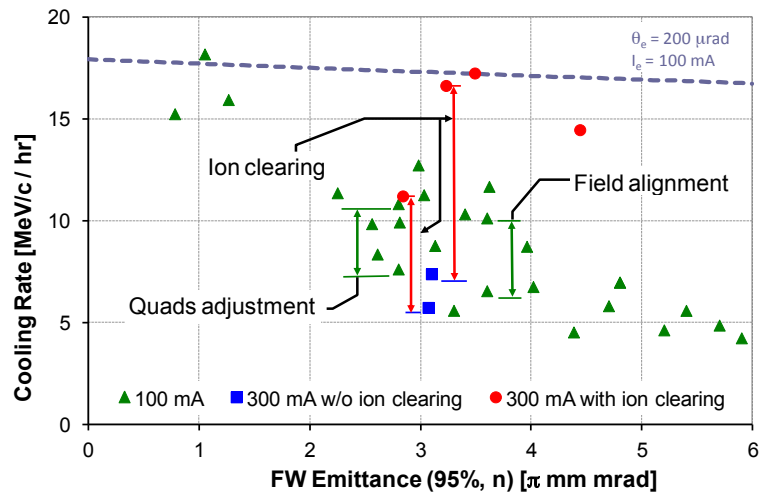

Longitudinal cooling rate measured in 2006-2010.

The arrows connect points measured on the same day to show the range of several improvements. All measurements are “on axis”.

Longitudinal cooling rate at 100 mA

Subset of the data where  $I_e = 100 \text{ mA}$  and for which the electron beam characteristics are similar

- Cooling rate can be calculated from cooling force measurement
- Radial dependence of the cooling force must be included in the calculation to catch the cooling rate dependence on the transverse emittance of the antiprotons
  - Dash curves on plots above: without (left) and with (right) inclusion of the radial dependence of the cooling force

## Summary of cooling improvements

---

- Tuning of focusing with quadrupoles
- Alignment of the magnetic field in the cooling section
- Ion clearing
  
- All improvements of cooling properties were made through decreasing the transverse electron velocities (angles) in the cooling section
  - The main study tool was the drag rate measurements
  - The total rms angle was decreased probably by 1.5 – 2 times

---

# Operation

## In operation

- July 9, 2005 – **First** indication of the cooling force
- Since then, Electron Cooling became an important part of the Tevatron complex
  - When the cooler is ‘broken’, the rate of integrating luminosity drops by  $\sim 3$
- The cooler’s performance was significantly improved and optimized
  - Procedures for tuning, feedback loops, automation...
  - Increasing of cooling rates
    - Allowed increasing the rate of unloading antiprotons from the Accumulator and improve emittances of the beam in the Tevatron
  - Optimization of the cooling scenario
    - Cooling off – axis
    - Cooling with a helical trajectory
    - Increasing the electron beam current for final cooling before extraction
- Significant efforts for maintenance

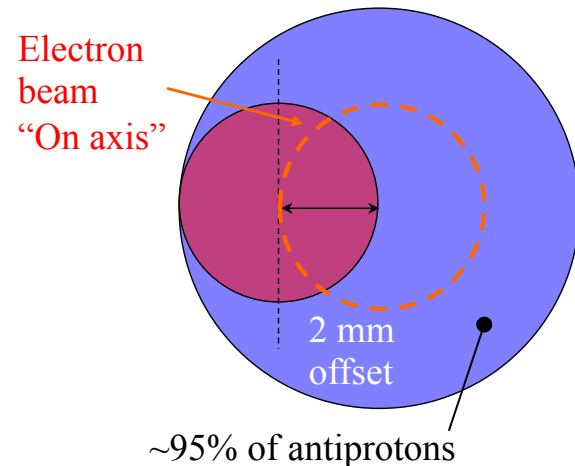



# Energy drift

- Temperature (inside and outside the Pelletron, electronics...) found to have a significant effect on our ability to keep the electron beam energy constant (hence matched to the antiproton beam momentum)
  - Used displacement of the beam in a high dispersion region to measure the true energy variations and feed it back to the controls system
  - Most reliable indication of an energy mismatch was the shape of the Schottky momentum distribution

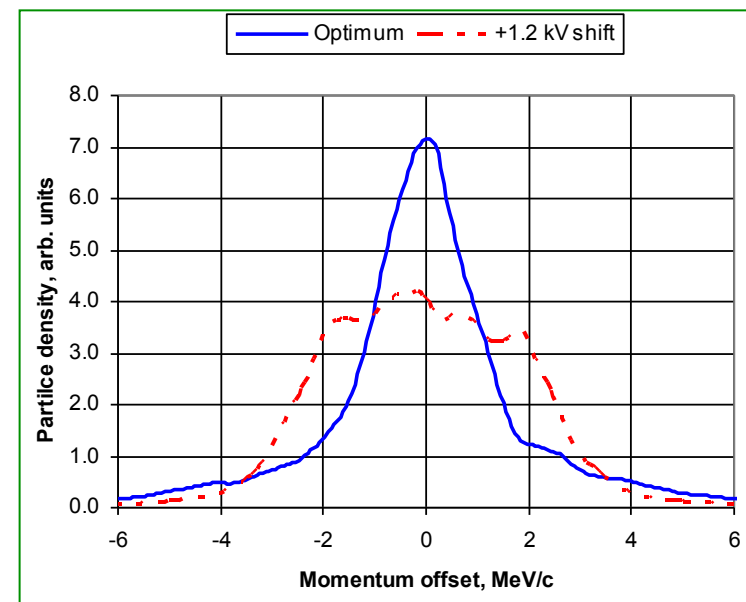
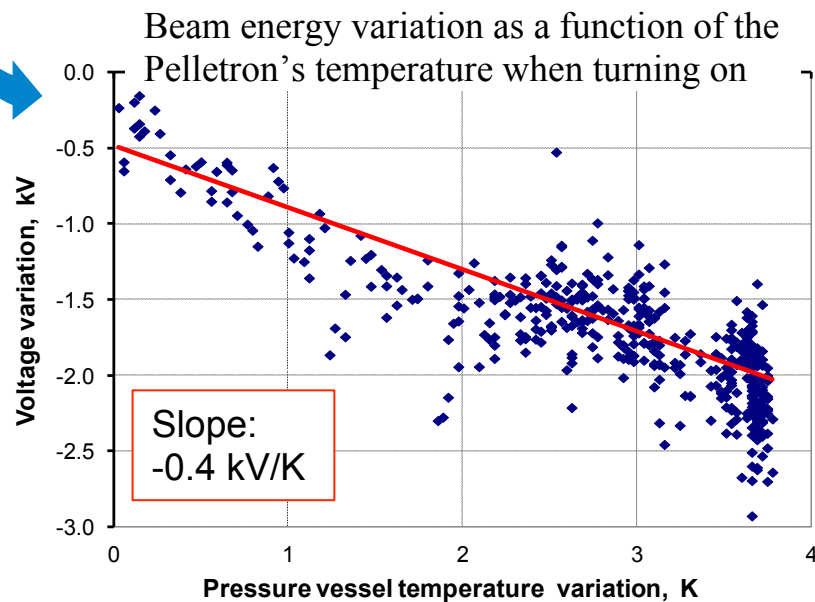

# Impedance-driven instability

- Due to own space charge of pbars when *deeply* cooled (very bright)

- Dampers suppressed them very efficiently
- A few were observed during extraction process

antiproton  $\equiv \bar{p} \equiv$  pbar

- Complicated RF gymnastics

- Defined a ‘phase density’ parameter

$$D_{95} = \frac{N_{\bar{p}}}{\epsilon_{L95} \cdot \epsilon_{Tn95}}$$

← # of pbar  $\times 10^{10}$   
 ← Emittances in eV·s &  $\mu\text{rad}$

- Monitored on-line
- Kept far from the calculated (and experimentally determined) instability threshold

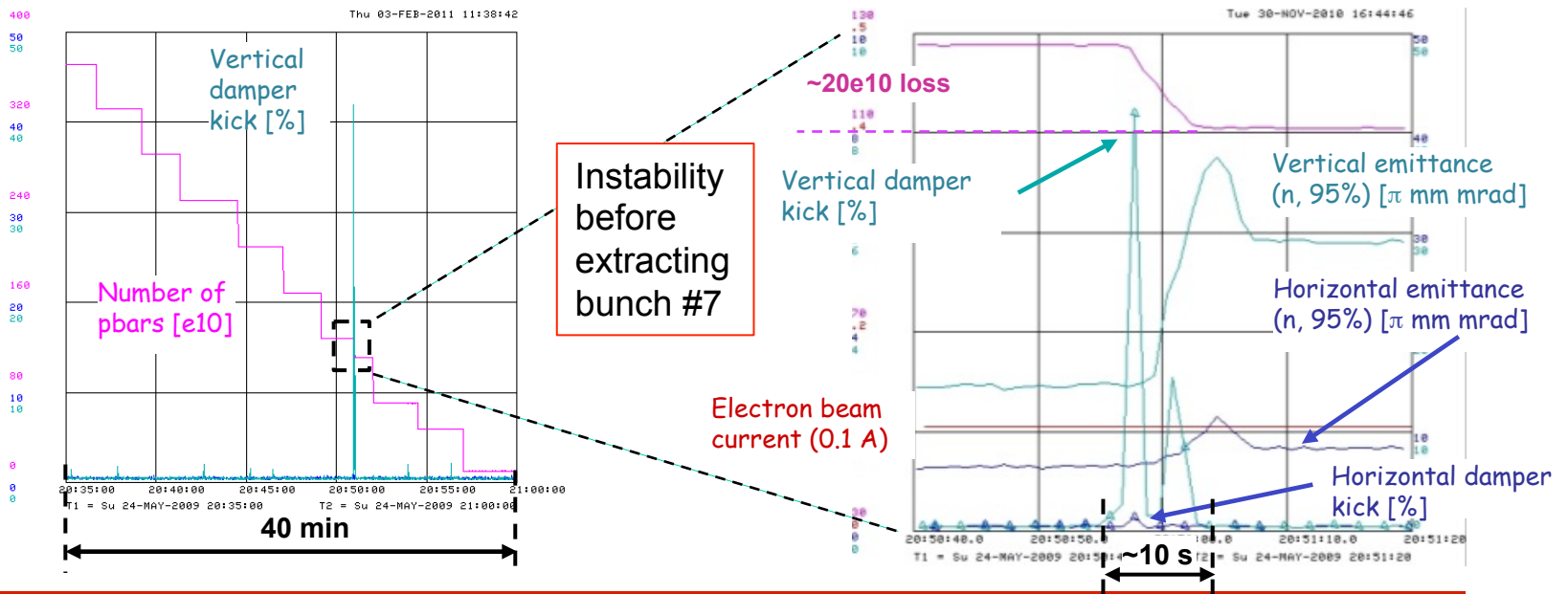

# Lifetime

- Antiprotons are typically accumulated for  $\sim 15$  hours
  - Preserving the antiproton beam lifetime is crucial
  - No single parameter (or a combination) would *uniquely* determine the lifetime
- Some observations:
  - The lifetime value correlates best with the linear density
    - But not with the transverse emittance for instance
  - Strong cooling deteriorates the lifetime – Stochastic cooling improves it
    - Keep stochastic cooling well tuned even if its effect on the measured emittance of large stacks was insignificant

The linear density is calculated as a ratio of the total number of antiprotons,  $\times 10^{10}$ , to the length of the RF barriers gap, in units of 53-MHz buckets - the Recycler perimeter in this unit is 588 buckets.

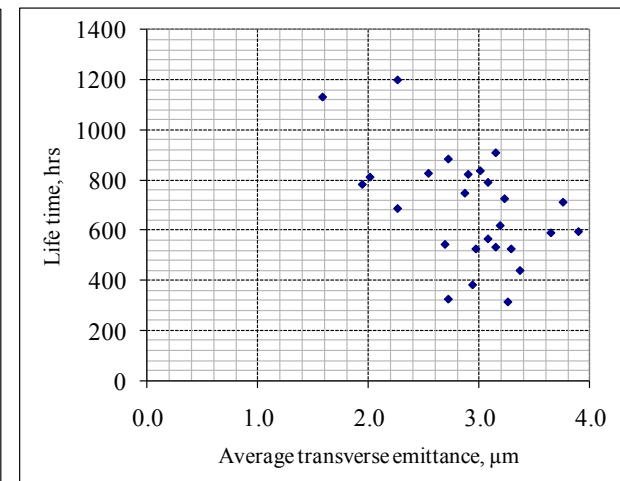
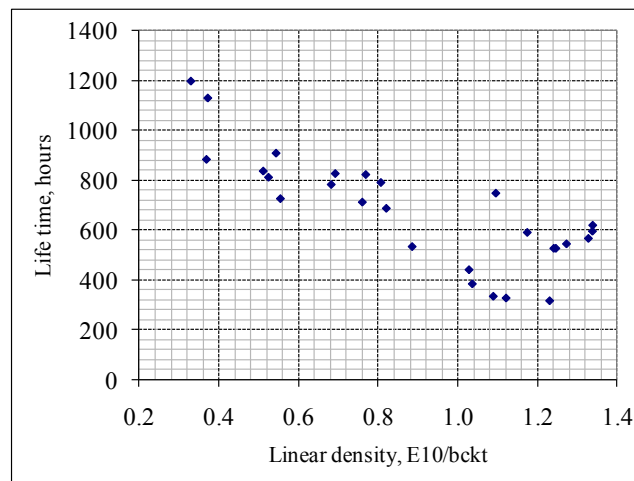

# Recycler cooling cycle

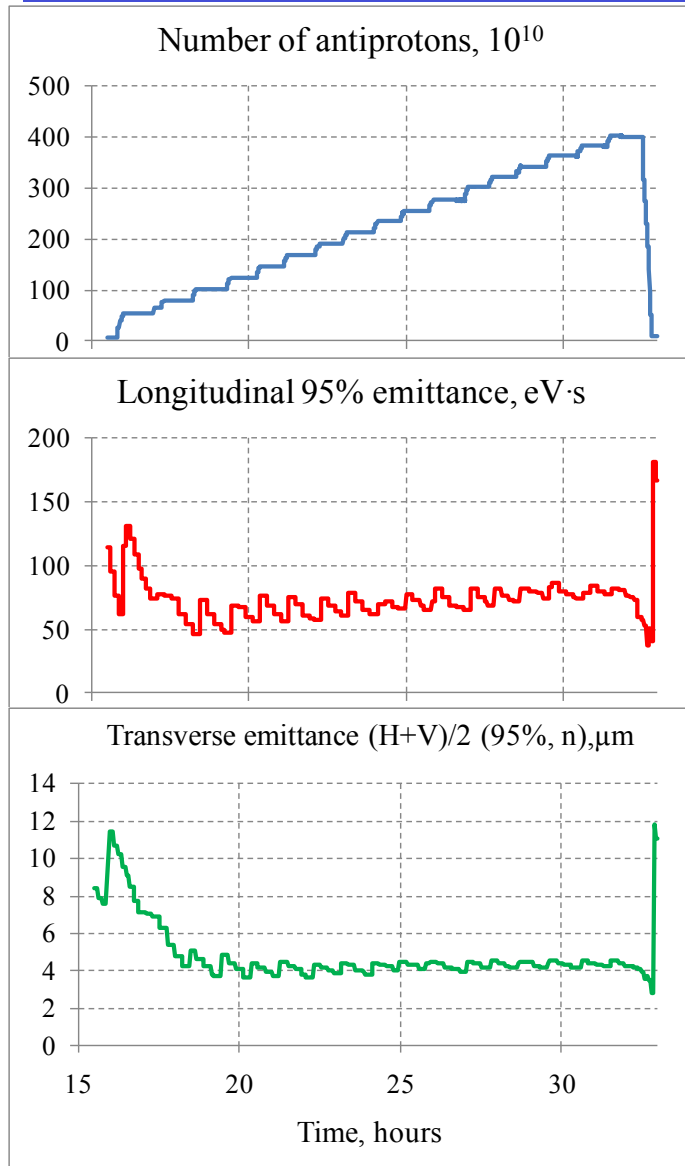

- Efficient storage of antiprotons
  - Typical beam loss due to the finite life time in the Recycler is ~5%
  - Number of stored antiprotons was up to  $6 \cdot 10^{12}$  with a life time  $> 300$  hrs
- Antiprotons cooled the parameters required for the Tevatron
  - Typically (for  $380-400 \times 10^{10}$  pbars):
    - 70 eV·s
    - 3 μrad (normalized, 95%)

Typical cycle of accumulation of antiprotons in the Recycler ring and following extraction.

June 17-18, 2011. Electron beam was kept at 0.1A , shifted by 2 mm from the axis except right before extraction, when it was switched to 0.2A in ion clearing mode and moved on axis. Average life time was 256 hours.

Average initial luminosity in the Tevatron was  $408 \times 10^{30} \text{ cm}^{-2} \text{ s}^{-1}$ .

## Summary

---

- Unique electron cooler
  - High energy (4 MV), huge beam power (2 MW)
  - Low magnetic field in the cooling section with lumped focusing outside
    - ‘Non-magnetized’ cooling
    - Transport of a beam with large effective emittance
  
- Reliable machine running 24/7
  
- The Recycler Electron Cooler significantly contributed to the success of Run-II

## The End

- The Recycler Electron Cooler was an interesting machine to work with
- Its operation ended on September 30, 2011 together with the Tevatron
  
- *Some accomplishments*

Pelletron		Electron beam		Cooling		Recycler	
Max. time between tank openings	7 months	Current density (center)	$0.6 \text{ A} \cdot \text{cm}^{-2}$	Max. drag rate (2 kV jump)	$97 \text{ MeV c}^{-1} \text{ hr}^{-1} @ 0.5 \text{ A}$ $57 \text{ MeV c}^{-1} \text{ hr}^{-1} @ 0.1 \text{ A}$	Max. # of stored pbars	$6.1 \times 10^{12}$
Max. current	$0.72 \text{ A}$ ( <i>full line</i> ) $0.5 \text{ A}$ ( <i>operation</i> ) $1.8 \text{ A}$ ( <i>short line</i> )	Effective energy spread	200 eV	e-cooling e-time	11 min ( <i>bunched beam</i> ) 2 min ( <i>DC beam</i> )	Most pbars sent to Tevatron in one week	$4.0 \times 10^{13}$
Relative beam loss	$2 \times 10^{-5}$ ( <i>full line</i> )	Beam angles	$\sim 0.1 \text{ mrad}$			Most pbars accumulated in one month	$1.5 \times 10^{14}$