

DESIGN OPTIMIZATION OF FLUX CONCENTRATOR FOR SuperKEKB*

L. Zang[†], T. Kamitani, S. Fukuda and Y. Ogawa
 High Energy Accelerator Research Organization (KEK)
 1-1 Oho, Tsukuba, Ibaraki, 305-0801, Japan

Abstract

For high luminosity electron-positron colliders, intense positron beam production is one of the key issues as well as electron. Flux Concentrator (FC) is a pulsed solenoid that can generate high magnetic field of several Tesla and is often used for focusing positrons emerged from a production target. It works as an optical matching device in a positron capture section. With this device, high capture efficiency is achieved. In this paper, we will discuss a design optimization of a FC for the SuperKEKB positron source. Geometrical parameters of the FC are optimized to achieve high peak field using the CST EM Studio [1]. Magnetic field distribution evaluated with the EM Studio is implemented into a particle tracking code to see a performance of the positron capture section. The tracking simulation includes a positron production at the target, focusing by the FC and subsequent solenoids and acceleration by RF structures till the end of the capture section. We report the results of a FC design optimized for higher positron yield with the tracking simulation.

INTRODUCTION

The SuperKEKB positron source is based on the conventional scheme. A 3.5 GeV electron beam strikes on a tungsten target to generate cascade shower [2]. The generated positrons are focused by a strong magnetic field provided by a matching device before acceleration. Positron beam after the target has a small size but large divergence angle. In the accelerating section it can have a relatively large size but should have a small divergence angle. A matching device such as flux concentrator could transform the phase space distribution from the target so that it is appropriate for the solenoid focusing field in the accelerating section: this improves the capture efficiency. The adiabatic matching device is made of a slowly changing magnetic field plus a long magnetic field. Between the maximum field B_0 and the minimum B_s , the magnetic field is characterized by the taper parameter g as shown in Eq.1.

$$B_z(z) = \frac{B_0}{1 + gz} \quad (1)$$

Key parameters for the adiabatic matching device are the initial field B_0 , the taper parameter and the physical aperture. Because the positron beam has a very wide energy

* Work supported by KEK

[†] zang@post.kek.jp

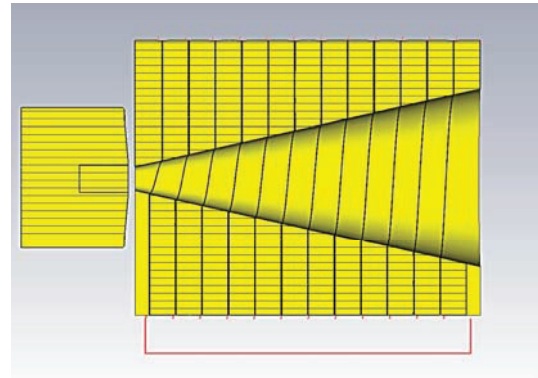

Figure 1: CST Model of the spiral slit Flux Concentrator.

spread, it is not possible to achieve perfect matching between target and solenoid in the linac. Optimization of the parameters to achieve high capture efficiency is best done by simulation. In the following sections, tracking simulation results of the flux concentrator and solenoid key parameters will be presented.

FLUX CONCENTRATOR MODELING

The flux concentrator consists of primary coil and conductor core. A pulsed current in the primary coil induces an eddy current in the conductor. Due to the skin effect, induced current is directed into the inner surface through a slit to produce a high magnetic field in small area [3]. In this section two proposed models are introduced: straight slit FC and spiral slit FC. These two models have been built in CST Studio to evaluate the field distribution. The simulations do not only help us understand the field shape, but also generate the field to implement into the tracking simulation. The spiral slit FC model has been shown in Fig.1. This design is initially developed by SLAC [4]. The copper coil is 100 mm, 12 turns and assuming a current of 16000 A. The copper core has a outer radius of 40 mm and a conical inner radius growing from 3.5 mm to 26 mm. There are certain advantages and disadvantages for each design. First of all, spiral slit FC is a rather complicated design compared with the straight slit FC, which makes it harder for machining. Secondly, the straight slit FC could produce higher peak field as shown in Fig.2, although the spiral slit has a better adiabatic field distribution. Finally, straight slit FC has a larger transverse field with long tail which could defocus the positron beam, whereas the spiral slit FC's transverse component is smaller.

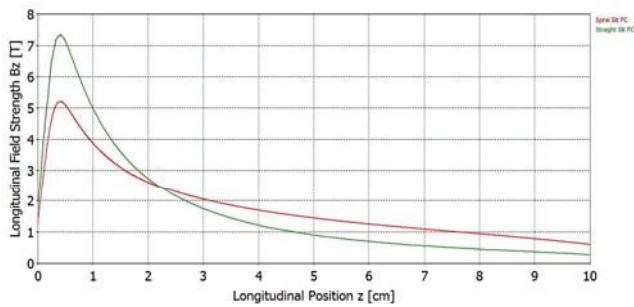

Figure 2: Spiral (red line) and straight (blue line) slit flux concentrator longitudinal field distribution.

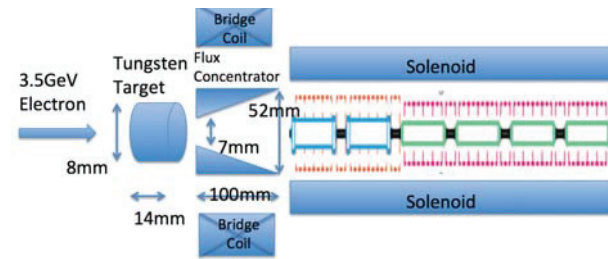

Figure 3: Schematic view of the SuperKEKB positron source configuration.

POSITRON SOURCE TRACKING SIMULATION

The motivation of FC optimization and tracking simulation is to improve the positron yield for SuperKEKB positron source. The capture section layout is based on the SuperKEKB design as shown in Fig.3. Positrons generation simulation is carried out by GEANT4 [5] assuming a 3.5 GeV electron strike on a 14 mm thick tungsten target. The positron beam phase space distribution is shown in Fig.4. The generated positrons go through the adiabatic matching device consisting of FC and bridge coil. Downstream of the matching section is the accelerating structures include two 2 m L -band and four 2 m of large aperture S -band accelerating units. Both kinds of accelerating units have an accelerating gradient of 10 MV/m [6]. The whole accelerating structure is surrounded by the solenoid. More detailed simulation results of positron yield in capture section by investigating the dependence upon some key parameters such as peak field, taper parameter and solenoid field strength will be presented in following sections.

Peak Field

The lateral acceptances r^{max} and the transverse momentum acceptance P_x^{max} could be roughly estimated by following expressions:

$$r^{max} = \sqrt{\frac{B_s}{B_0}} a \quad (2)$$

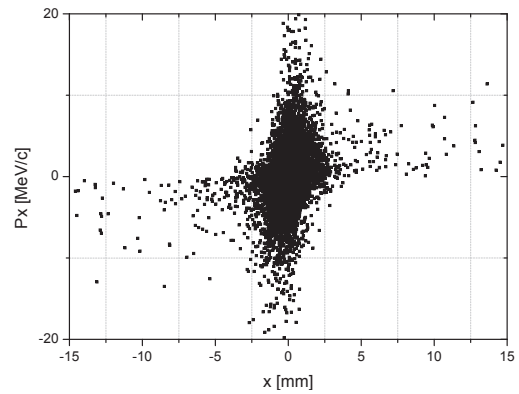

Figure 4: Initial positron beam phase space distribution.

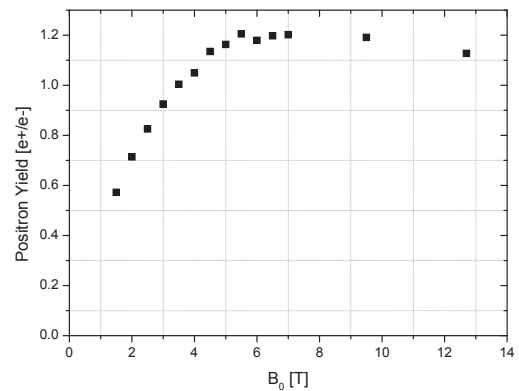

Figure 5: Positron yield as a function of maximum adiabatic matching device field B_0 .

$$P_x^{max} = e\sqrt{B_0 B_s} a \quad (3)$$

where B_0 and B_s represents the maximum and minimum magnetic field of adiabatic matching device respectively.

In the simulation, the field length is fixed (various taper parameters), and the peak field will be scanned from 1.5 T to 11.7 T to investigate the correlation between the maximum field B_0 and positron yield, where the positron yield is defined as the number of positrons per primary electron at the end of capture section. The results have been presented in Fig.5 which shows the positron yield as a function of maximum adiabatic matching device field B_0 . We can divide the plot into two regions to analyze it: region 1 from 1.5 T to 6 T and region 2 from 6 T to 12.7 T. In region 1, B_0 changes from 1.5 T to 6 T. In this process, theoretically the transverse momentum acceptance is increased by a factor of 2, whereas the lateral acceptance is reduced by the same factor. Because the positron beam after the target has a fairly small lateral dimension, the reduction of lateral acceptance will not cause serious positron losses. As we have seen in Fig.4, the transverse momentum of positron beam is rather large, so it is efficient to improve the positron yield by increasing the transverse momentum acceptance. As we can see in Fig.5 the positron yield could be improved

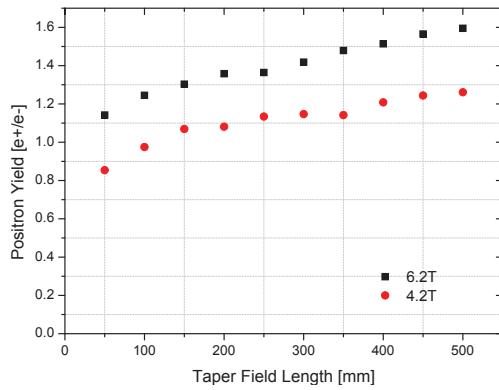

Figure 6: Positron yield as a function of taper field length. The black dots and red dots represent the 6.2 T case and 4.2 T case respectively.

from 0.6 to 1.2. However, in region 2, instead of capturing more positrons, the capture efficiency starts to saturate. For instance, the extreme case of using 12.7 T field, and the positron yield is even lower than the 6 T case. When a much higher field is applied, the reduction of lateral acceptance starts to cut out more off-axis positrons. And the large transverse momentum acceptance is less effective because most of positrons have been already in the acceptance level. Therefore, positron capture efficiency is saturated for a higher field than 6 T.

Taper Parameter

Ideally, an adiabatic field distribution could provide the demanded phase space transformation. A smaller taper parameter defines a smoother adiabatic field distribution, but that could lead to a very long FC. For a fixed peak field strength, the larger the taper parameter is, the smaller the energy acceptance. Fig.6 shows the positron yield as a function of the taper field length for fixed peak field of 6.2 T and 4.2 T.

Field of 6.2 T and 4.2 T has the similar tendency. If we assume the 200 mm field length as a default choice, to increase the taper field length to 500 mm could effectively improve the positron yield about 18.5% and 13.6% for 6.2 T and 4.2 T respectively. Whereas shortening the taper field length could lead to the lower positron yield.

Solenoid

After passing through the matching device, positrons go into a long solenoid field till the end of the capture section. In this section, we will look into the influence of the solenoid field to the positron yield. Fig.7 shows the positron yield as a function of solenoid field. The black dots and red dots represent the peak field of 6.2 T and 4.2 T.

When the solenoid field increase from 0.1 T to 0.8 T, the positron number increase linearly. For example, solenoid field increase from 0.4 T to 0.5 T would lead to an extra

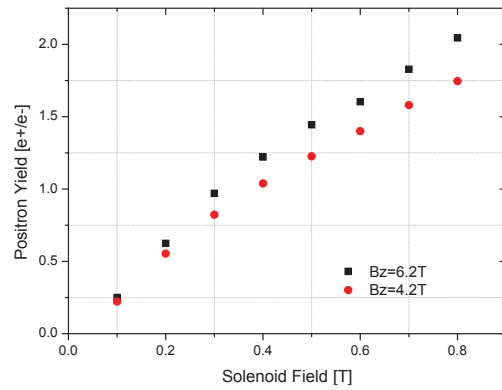

Figure 7: Positron yield as a function of solenoid field strength. The black dots and red dots represent the 6.2 T case and 4.2 T case respectively.

20% gain of positron yield. For the SuperKEKB solenoid, 0.4 T is the nominal design value.

CONCLUSIONS

Between the positron production target and the first acceleration section, the FC plays an important role as a part of matching device. We have studied the positron yield as functions of the peak field, taper parameter and solenoid field. The initial field about 6 T is an optimal choice. When the peak field is fixed, the taper parameter should be small. However, small taper parameter could end with a very long flux concentrator, so that this value is restricted by the space that reserved for flux concentrator. Furthermore, the solenoid field could help to improve the positron yield. So far the simulation is finished at the end of capture section. After the capture section, the focusing system and damping ring has a small transverse phase space acceptance and energy acceptance respectively, which could reduce the final positron yield. Hence, in the future, the tracking simulation will be extended to the downstream including the quadrupole and the damping ring.

REFERENCES

- [1] CST EM STUDIO, “Low Frequency Electromagnetic Design and Simulation”.
- [2] SuperKEKB Task Force, “Letter of Intent for KEK Super B Factory”, KEK Report 2004-4, June 2004.
- [3] L. Hoffmann and V. Scheuing, “Transformer Coils for High Magnetic Fields”, CERN 63-36, Nuclear Physics Division, 22nd October, 1963.
- [4] A. V. Kulikov, S. D. Ecklund and E. M. Reuter, “SLC Positron Source Pulsed Flux Concentrator”, SLAC-PUB-5473, June, 1991.
- [5] Geant4 Collaboration, “Geant4 User’s Guide for Application Developers”, 2nd December, 2011; <http://geant4.cern.ch/>
- [6] T. Kamitani, “Positron Source Upgrade”, KEKB review.