

RELIABILITY MODELING METHOD FOR PROTON ACCELERATOR

S. Bhattacharyya, R. K. Yedavalli, The Ohio State University, Columbus, OH 43201, USA

J. Kerby, A. Mukherjee, Fermilab, Batavia, IL 60510, USA

Abstract

Reliability modeling and analysis forms an important part of designing any complex system. It helps to analyze the performance over the predicted lifetime, and gives insight to the weakness in design based on the predicted failures. Reliability analysis of particle accelerator is still not a widely used in the physics community. However, since future accelerators are likely to be more powerful and more expensive, a feasibility study during the design phase becomes essential. Further application of accelerators in nuclear technology, like in Accelerator Driven Systems^[1], makes a thorough reliability study indispensable. In this paper, we discuss reliability modeling and analysis for a proposed high intensity proton linear accelerator (linac), Project X^[2] at Fermi National Accelerator Laboratory (Fermilab), IL, USA.

RELIABILITY MODELING FOR ACCELERATORS

Reliability Concepts

Reliability can be defined as “the probability that a system will perform its intended function for a specified interval of time under the stated conditions”^[3]. It helps to

- Build & understand system failure model
- Compute expected lifetime, net downtime (Availability)
- Estimate total Repair Time and mean time between repairs
- Identify weak points in the design
- Identify critical components
- Understand component interdependencies
- Estimate allocated resources, labors, spares

Some of the important concepts in relation to reliability are Reliability $R(t)$, Availability $A(t)$, Failure Density Function $f(t)$, Cumulative Failure Density $F(t)$, Mean Time Between Failure ($MTBF$), and Mean Time To Repair ($MTTR$). These terms are defined in appendix A.

Reliability for Particle Accelerators

Many past accelerators were designed and built without a formal reliability analysis, including the Tevatron (presently Fermilab’s primary accelerator). However, for a new proposed proton accelerator called “Project X”, we decided to perform a feasibility and reliability analysis. Project X differs from Tevatron in a few respects:

- Reliability analysis (and the tools to perform it) was not as widely used at the time the Tevatron was designed.
- The unique feature of the Tevatron was the highest energy beam (at that time), and experimenters could take advantage of this even with initially low

availability. In comparison, the key feature of Project X is high intensity, and total available beam is crucial to designing experiments.

- The funding situation makes unanticipated operating costs unacceptable. Before Project X gets final approval, it must demonstrate that it can meet the requirements specified in the Reference Design Report^[4]: 90% for the 3GeV section, 85% for 6-120GeV.

In comparison to the Tevatron and other existing accelerators, the required reliability of Project X is ambitious but not dramatically so. But the other factor that necessitates the feasibility study of Project X is that the linac forms the groundwork for Accelerator Driven Subcritical System (ADSS) (or Accelerator Driven Subcritical Reactor). The reliability requirement for ADSS is more stringent and more complex. Availability must be >99% compared to <80% for the Tevatron and there may be a maximum of 3-5 failures a year, compared to 70-80 typical for existing accelerators. Hence a thorough reliability and failure analysis becomes crucial for such systems to identify the shortcomings and fix them in the final design

Reliability Methodologies and Tools

Some of the common methods of reliability analysis are listed below:

- Reliability Block Diagram (RBD)
- Fault Tree Analysis
- Markov Modeling
- Failure mode and effect analysis (FMEA)
- Weibull Analysis
- Simulation (Monte Carlo), often coupled with some of the above concepts

In our research, we use the RBD method along with hierarchical modeling and parameterization to represent the Project X linac.

Though no systematic analysis has been carried out extensively on reliability of accelerators, there has been some work done in this field. A reliability study of the Spallation Neutron Source (SNS) has been done using a spread sheet (Oak Ridge National Laboratory)^[5], and customized reliability software called AvailSim^[6] was developed for the proposed International Linear Collider (SLAC). Our present work on reliability of Project X uses commercial simulation software called Availability Workbench (AWB)^[7] by Isograph. Some accelerator specific complexities cannot be fully represented by commercial software. We chose AWB since it gives us the flexibility of interfacing it with other programs, and passing on the data to anyone.

Table 1: Comparison of Reliability Tools

Tool	Pros	Cons
Spreadsheet	Previously used by SNS. Deterministic. Good to get started. Good source of data for our present work.	User interface hard to use. Lack of visualization tools makes it difficult to locate problems. Error prone.
AvailSim	Many accelerator specific concepts built in. Free – can be used by anyone.	No GUI. Not validated against real data.
Sapphire (semi-commercial)	Widely used in NASA and nuclear industry. Developed by Idaho National Lab, free to use.	NDA per user.
ReliaSoft (commercial)	Good user interface. Most widely used reliability package with many options. SNS uses.	File format is proprietary. Cannot access except through ReliaSoft.
Isograph's AWB (commercial)	Good user interface. File format is open, accessible by any program.	Not as widely used as ReliaSoft, and lacks some GUI features.

MODELLING METHODOLOGIES

Failure Distribution

Many probability distribution models are used to model the failure distribution, such as Exponential, Weibull, Normal, Poisson, Chi-square, Gamma, and so on. In our model, for simplicity, we assumed all failures to be exponential. This is based on what is defined in SNS spreadsheet which we refer for our data source. Means, we have, $F(t) = 1 - e^{-\lambda t}$, where λ is the failure rate and it is constant with time.

Subsystems Modeled

Project X linac has been divided into thirteen main systems, which we model for our reliability study. For validating our modeling idea, we use SNS data. Some of the subsystems of SNS are similar to that of Project X, both being proton linacs with superconducting RF cavities. We focused our validation on these common subsystems. Project X has been divided into the following main subsystems at the top level which are in "series" relationship. They are conventional facilities, beam

vacuum, global insulating vacuum, global cryogenics, LEBT, RFQ, MEBT, HWR, 325 MHz section, 650 MHz section, magnet package and beam instrumentation package respectively.

Building the Model

There are two types of modeling techniques:

Hierarchical graphics with no parameterization: Can migrate to bottom most level. The whole system with all its subsystems forms a single RBD, i.e. a single project. This can be cumbersome to handle and requires very large computational time.

Hierarchical modeling with sub-system parameterization: Allows less computational time. It is much easier to represent. Each subsystem is studied separately as an independent project.

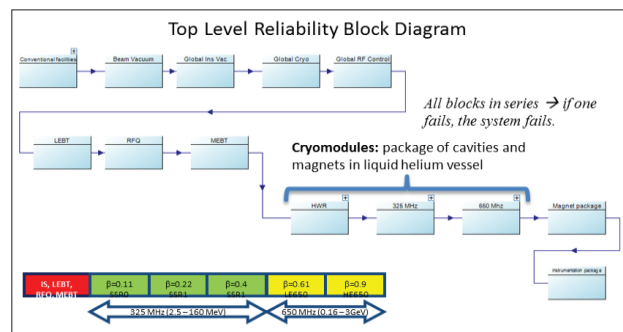

Figure 1: Project X top level RBD.

However, parameterizing has both pros and cons: it makes some features more complex to implement, and some easier. We developed a Project- X model as a single project with most of the major subsystems in AWB. It takes ~35 hours to complete simulation with around 300 components. We have neglected the components which occur >50 times and taken them as one block. Were we to develop the entire full scale system with all instances, there would be ~30000 components, requiring a simulation time of 3500 hours. In contrast, the Project X model with parameterized blocks can run in as less as 1 hour. In the next sections we will talk about the modeling procedure taking particular examples.

Example of Cryomodule Modeling

We parameterize systems so that we can treat them as a single block or as a smaller number of blocks when used in top level. To do this we work on each system as an individual project, and characterize its MTBF and repair distribution. The concept of repair distribution is very important, since, in some systems, the repair varies from a few hours to a hundred hours. So, the MTTR or the average repair time is not useful, the repair should follow a distribution. In Figure 2, we explain in a simple way, how a cryomodule can be modeled. It is assumed anything in cold volume (cold magnet, cavity) has repair time ~400 hours. Further, the cryomodule is a $n - 1$ out of n system, means it can take up to 1 failure. Load on

Copyright © 2012 by IEEE - cc Creative Commons Attribution 3.0 (CC BY 3.0) — cc Creative Commons Attribution 3.0 (CC BY 3.0)

system increases after 1 failure Data available as of now is not reliable, but have been put in for testing purpose.

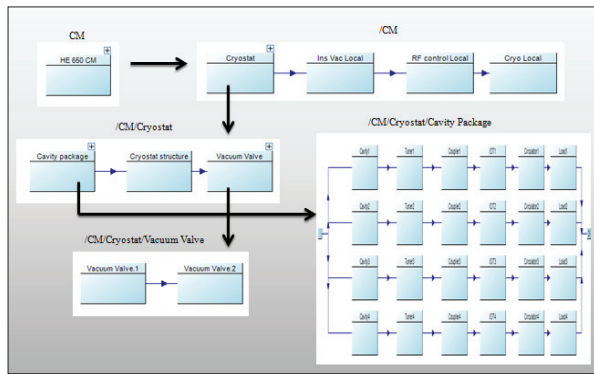

Figure 2: Cryomodule RBD

The cumulative failure distribution is shown in Figure 3, with a fit overlaid. In Figure 3a, X axis gives the MTBF in hours and the Y axis shows the cumulative failure probability.

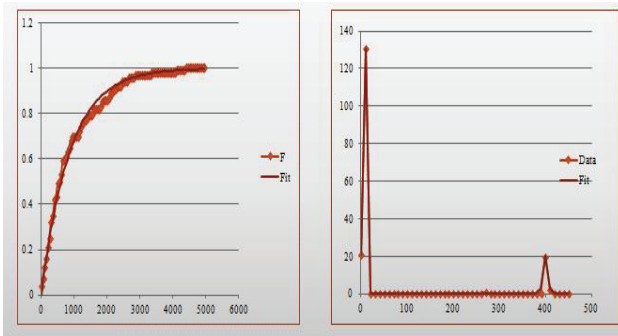

Figure 3: Failure and Repair Distribution

The repair distribution, parameterized by three distinct functions, can be reproduced using 3 sub blocks as shown in Figure 4. The area under each of the functions in Figure 3 is translated to an effective MTBF of each of the sub blocks so as to correctly populate the repair time distributions. This simplified description of the “HE650” cryomodule retains all the information relevant to simulating the system. Magnet Package, Ion Source/LEBT systems have been modeled similarly following this method.

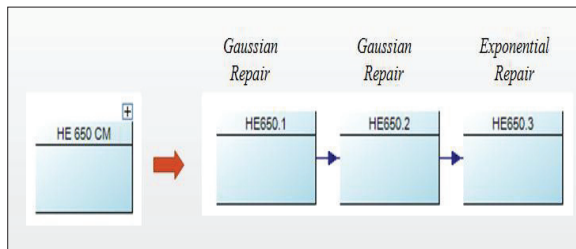

Figure 4: Entire cryomodule reduced to three blocks

RESULTS

We validated our methodology and results against the reliability data from SNS spreadsheet. Spreadsheet being

prone to error, we fixed some error prior to validation. We modeled some of the systems using AWB and compared the repair time which is shown in Table 2.

Table 2: Comparison of SNS and AWB Results

Systems	MTBF		Difference	# of simulations	Lifetime
	Spread Sheet	AWB			
MEBSCL	4476	4479	0.06	10 ⁴	12x10 ⁴
Ion source	53.9	53.5	-0.75	10 ³	1x10 ³
Cryoplant	1306	1290	-1.2	10 ³	5x10 ³
RFQ	4804	4798	-0.12	10 ³	15x10 ³
MEBT	827.6	828.1	0.06	10 ³	3x10 ³

It is to be noted, lifetime in this respect means the number of simulation hours. As we can see, using component data from SNS, the MTBF of the systems are in agreement with those from SNS within 1.5% error when AWB is used. Reliability Block Diagram procedure, as discussed can be cumbersome when building very large systems with thousands of blocks. Hence a C program has been developed to automate block formation. As soon as reliable data for the subcomponents is available, a meaningful analysis of the system can be performed easily.

REFERENCES

- [1] Abderrahim *et al.*, "Accelerator and Target Technology for Accelerator Driven Transmutation and Energy Production" (2010).
- [2] Yousry Gohar, David Johnson, Todd Johnson and Shekhar Mishra, "Fermilab Project X Nuclear Energy Application: Accelerator, Spallation Target and Transmutation Technology Demonstration", (2010). (indico.fnal.gov).
- [3] "Engineering Reliability: Fundamentals and Applications", R. Ramakumar, ISBN 0-13-276759-7.
- [4] "Project X Reference Design Report", S. Holmes, 2010. projectx-docdb document 776-v1.
- [5] J Galambos, "Operational Experience at the MW Level," *ICFA 2010*, Morschach, Switzerland, Sept. 27, 2010.
- [6] T. Himel, J. Nelson, N. Phinney, M. Ross "Availability and Reliability Issues for ILC", Particle Accelerator Conference (PAC 07), Albuquerque, NM, USA, June 2007.
- [7] Isograph Ltd (2009), Isograph software suites, (www.isograph-software.com). Accessed 3 Jan 2009.