

HIE-ISOLDE SC LINAC: OPERATIONAL ASPECTS AND COMMISSIONING PREPARATION

D. Voulot, E. Bravin, M. Fraser, B. Goddard, Y. Kadi, D. Lanaia, A. Parfenova, M. Pasini, A. Sosa, F. Zocca, CERN, Geneva, Switzerland

Abstract

In the framework of the HIE-ISOLDE project, the REX linac will be upgraded in stages to 5.5 MeV/u and 10 MeV/u using superconducting (SC) quarter-wave cavities. The linac lattice is now frozen and the beam dynamics has been checked. The beam properties at the output of the NC linac for the different stages have been measured and are compatible with the SC linac acceptance. The high-energy beam transfer design is being finalised and a study has been launched for a buncher/chopper system allowing 100 ns bunch spacing for time-of-flight measurements. A compact diagnostic box for the inter-cryomodule region is under development and a new Si-detector based monitor for energy and phase measurements has been tested.

INTRODUCTION

The REX-ISOLDE post-accelerator has been operational since 2001 and provides post-accelerated radioactive ion beams (RIB) at energies ranging from 1.2 to 3 MeV/u for $A/q \leq 4.5$. The ISOLDE beams are charge-bred with a combination of Penning trap and electron beam ion source providing low-emittance highly charged ion beams that can be post-accelerated in a compact normal conducting linac operating at a base frequency of 101.28MHz. The REX linac upgrade planned as part of the HIE-ISOLDE project will increase in stages the beam energy to 10 MeV/u for RIB of mass to charge ratio of 4.5 by extending and replacing part of the NC linac with superconducting quarter-wave resonator SC cavities. The aim is to achieve full energy variability and operational flexibility while maintaining beam quality and keeping a very compact linac design compatible with the existing ISOLDE building. Full detail on the linac installation and staging can be found elsewhere in these proceedings [1]. The combination of the existing REX post-accelerator with the new SC linac will entail a number of challenges both in terms of beam dynamics and operation. We present a status report of the linac upgrade project focussing on beam dynamics, beam diagnostics and operational aspects of the future linac.

BEAM DYNAMICS

The choice of transverse optics and beam dynamics design of the linac was driven by the need to minimise the length of the machine while maintaining good emittances and high transmission. The superconducting accelerator will be based on two QWR geometries with geometric reduced velocities β_g of 6.3% and 10.3% respectively. Two geometries are necessary to cover the full velocity range. In total 32 cavities will be installed in six

cryomodules providing a total acceleration voltage of 39.6 MV. Transverse focussing will be achieved using superconducting solenoids housed inside of the cryomodules, which maximise the transverse acceptance and are less sensitive to mismatch. This configuration also provides beam waists in the inter-cryomodule regions where beam diagnostics and correctors can be inserted. The SC linac will be installed in three phases, with the high-beta cryomodules installed first to reach as early as possible 5.5 MeV/u (Stage 1) and 10 MeV/u (Stage 2a) and finally the energy variable part of the NC linac will be replaced with the low-beta section (Stage 2b). A pre-buncher and chopper are also foreseen in the final stage of installation to provide a bunch spacing of about 100 ns i.e. ten times the natural bunch spacing. The installation stages are shown in Figure 1.

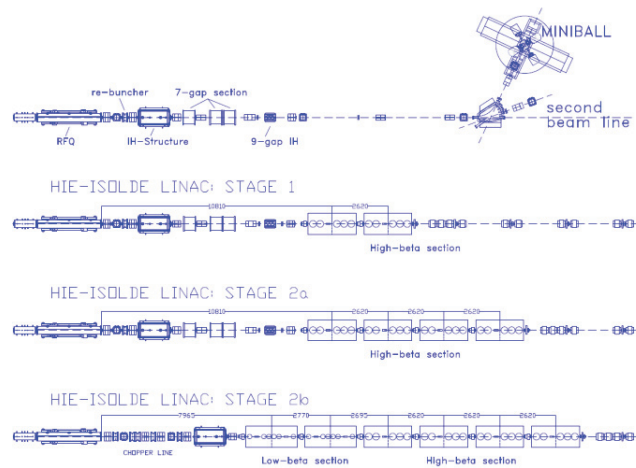

Figure 1: Linac layout at the various installation stages.

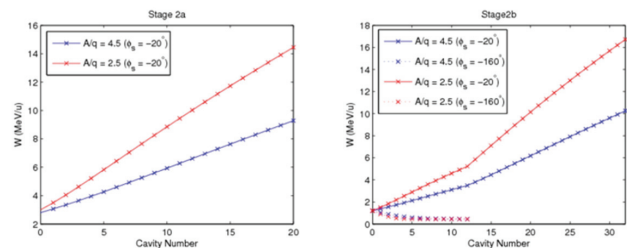

Figure 2: SC linac energy as a function of cavity number for the lowest and highest A/q .

The choice of independently phased SC cavities guarantees a maximum flexibility which means that the full accelerating voltage is available for the whole range of A/q . In its final stage the linac energy will be fully variable between 1.2 and 10 MeV/u for the heaviest ion beams ($A/q = 4.5$) while the lightest beams ($A/q = 2.5$)

will be accelerated up to 16 MeV/u. The possibility of decelerating will also exist: using the low-beta cavities energies down to 0.45 MeV/u can be attained [2]. Figure 2 shows the energy available after each cavity for the different stages and A/q .

Both the transverse and longitudinal emittances of the existing NC linac have been measured and are compatible with the acceptance of the SC linac for the different stages. The transverse emittance of the NC linac as a function of energy is shown in Figure 3. A transverse normalised emittance of 0.30 mm.mrad was used for the SC linac design.

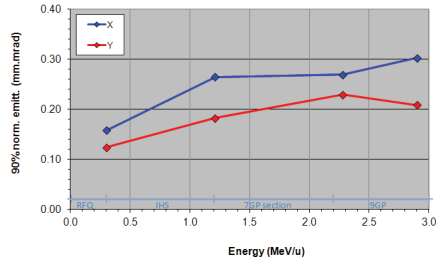

Figure 3: Transverse emittance of the NC linac as a function of energy.

The longitudinal emittance has been measured using the three gradient method both at RFQ and third 7-gap energy [3]. An example is given in Figure 4. Longitudinal 86%-emittances of 1.48 ns.keV/u and 1.55 ns.keV/u were measured respectively at the output of the RFQ and the third 7-gap structure. This is consistent with the measurement taken during the commissioning of REX and the 2 ns.keV/u value that was assumed for the SC linac simulations.

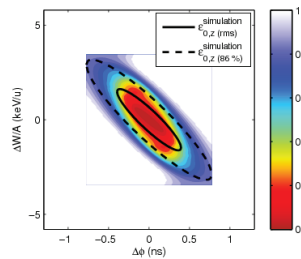

Figure 4: Contour map of measured longitudinal emittance at the output of the third 7-gap structure overlaid with the simulated longitudinal emittance ellipse.

PRE-BUNCHER AND CHOPPER LINE

The base frequency of the linac at 101.28 MHz provides a bunch spacing of about 10 ns. This is too short to allow experiments making use of time of flight techniques. For this purpose a buncher/chopper system has been proposed and is under study to allow 100 ns bunch spacing while maintaining high transmission and full background suppression between the bunches. This implies the installation of a pre-buncher operating at one tenth of the base frequency upstream of the RFQ and a chopper line. The extra space necessary is obtained by

shifting the SC linac by one cryomodule length as shown in Figure 1.

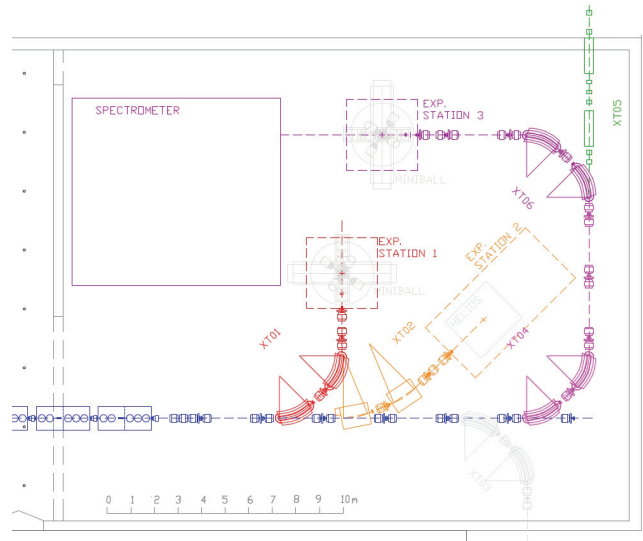

Figure 5: Layout of the High Energy Transfer lines in the ISOLDE experimental hall. Three beamlines are planned and some space is reserved for possible extensions like a recoil separator or the connection of a storage ring at the back of the hall (XT05).

HIGH ENERGY BEAM TRANSFER

Three experimental stations are foreseen behind the SC linac to accommodate the existing Miniball gamma array, a new HELIOS type [4] experiment and a multipurpose beamline. The layout of the High Energy Beam Transfer (HEBT) lines has to be compatible with the available space in the ISOLDE hall and allow for future experiments and extensions like a possible recoil separator behind Miniball or the connection of a storage ring which is foreseen to be installed in a separate building next to ISOLDE [5]. The final HEBT layout is shown in Figure 5.

In addition the transfer line has to be modular to allow for the staged installation of the SC linac. A periodic focussing channel was chosen with a period of 2.62 m, identical to the length of the high beta cryomodule, based on a doublet channel with alternating long and short drifts allowing for the insertion of bending magnets in the long drifts and beam diagnostics and corrector magnets in the short drifts between the quadrupoles. A 90 deg phase advance is used between the corrector magnet and the beam position monitors in the following period. The layout and optics was optimised to minimise the number of magnet families so that only one type of quadrupole and two types of dipole are employed. Buncher cavities are not foreseen in the baseline HEBT but by compromising the maximum energy some of the main linac RF can be used to give satisfactory longitudinal beam parameters in most cases at the experimental target positions. For the medium and high energies i.e. above

5.5 MeV/u, energy spreads below 0.6% FWHM and time spreads below 1.5 ns FWHM can be achieved.

BEAM DIAGNOSTICS

A compact diagnostics box is under development for the inter-cryomodule region comprising a Faraday cup and slit scanner for intensity and transverse profile and position measurements. The box is modular with four extra ports for pumping and extra diagnostics tools such as collimators or low intensity detectors. A 3D model is shown in Figure 6. The same design will be used for the high energy transfer lines. The specificity of the REX machine is the faint beams used for setting up, typically a few 10 ppA, and the necessity to scale the linac between pilot beams and the weak radioactive beams. Full details are given elsewhere in these proceedings [6].

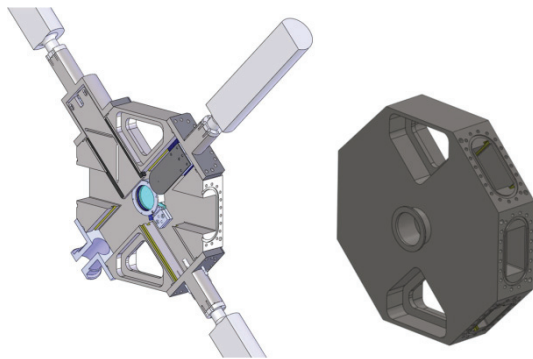

Figure 6: 3D model of the short diagnostic box [6].

A Si-detector based monitor has been developed for relative energy and phase measurements. This device can provide energy and phase spread information for longitudinal profile and emittance measurements. An energy and time spectra is shown in Figure 7. More details can be found in [7]. An emittance meter using the slit system of two consecutive short boxes is foreseen for transverse emittance measurement. A time of flight system for absolute energy measurements is also considered.

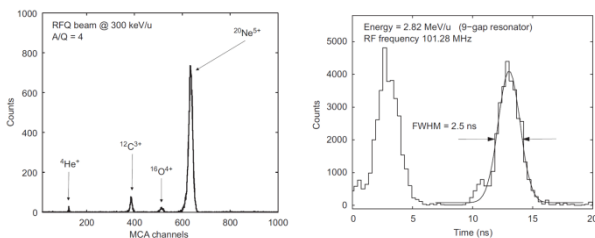

Figure 7: Energy and time spectrum of the Si-detet [7].

OPERATIONAL ASPECTS

The size and complexity of the machine will increase with the energy upgrade, for example the number of RF cavities will increase from 7 in the present NC linac to 35 in the final version of the HIE linac. The cavity phases will also become A/q dependent as the velocity profile

changes with A/q in the SC part of the linac. For this reason an automatic phasing procedure is foreseen using the above described Si-det either by tracking the relative energy change or, when the 100 ns bunch spacing becomes available, using a time of flight method. The possibility of using calculated settings and automated optimisation software is also investigated and some initial tests have already been done on the existing linac.

OUTLOOK

The main design parameters and the layout of the linac and HEBT are frozen and most components are now in their final design or prototyping stage. In the coming months a number of pre-commissioning tests will take place to validate the beam diagnostics and operational scenario. The first stage of the linac and transfer lines installation should be completed by mid 2014. Commissioning at 5.5 MeV/u is foreseen in the second half of 2014 with the first physics runs at 5.5 MeV/u taking place in 2015.

ACKNOWLEDGMENT

Two of the authors, DL and AGS, would like to acknowledge the receipt of fellowships from the CATHI Marie Curie Initial Training Network: FP7-PEOPLE-2010-ITN Project number 264330.

REFERENCES

- [1] Y. Kadi, "Status and Future Perspectives of the HIE-ISOLDE Project at CERN", these proceedings, MOOBA02
- [2] M.A. Fraser, R. M. Jones, and M. Pasini. "Beam Dynamics Design Studies of a Superconducting Radioactive Ion Beam Postaccelerator." Physical Review Special Topics - Accelerators and Beams 14, no. 2 (2011)
- [3] M.A. Fraser, F. Zocca, R.M. Jones, M. Pasini, P.A. Posocco, D. Voulot, and F. Wenander. "Longitudinal Emittance Measurements at REX-ISOLDE." Nuclear Instruments and Methods in Physics Research Section A: Accelerators, Spectrometers, Detectors and Associated Equipment 663, no. 1 (2012)
- [4] A. H. Wuosmaa, J. P. Schiffer, B. B. Back, C. J. Lister, K. E. Rehm, "A Solenoidal Spectrometer for Reactions in Inverse Kinematics", Nucl. Instr. Meth. A580, 1290 (2007)
- [5] K. Blaum, R. Raabe, "Storage ring facility at HIE-ISOLDE : Technical Design Report", CERN-INTC-2012-027 ; INTC-O-014
- [6] A. Sosa et al, "Beam instrumentation for the HIE-ISOLDE linac at CERN", these proceedings, MOPPR048
- [7] F.Zocca, M.A.Fraser, E.Bravin, M.Pasini, D.Voulot, F.Wenander, "Development of a silicon detector monitor for the HIE-ISOLDE superconducting upgrade of the REX-ISOLDE heavy-ion linac", Nucl. Instrum. Methods Phys. Res. A, vol. 672, pp. 21-28 (2012)