

LINAC4 LOW ENERGY BEAM MEASUREMENTS

L.M. Hein, G. Bellodi, J.-B. Lallement, A.M. Lombardi, O. Middtun, P. Posocco and R. Scrivens
 CERN, Geneva, Switzerland

Abstract

Linac4 is a 160 MeV normal-conducting linear accelerator for negative Hydrogen ions (H^-), which will replace the 50 MeV proton Linac (Linac2) as linear injector for the CERN accelerators. The low energy part, comprising a 45 keV Low Energy Beam Transport system (LEBT), a 3 MeV Radiofrequency Quadrupole (RFQ) and a Medium Energy Beam Transport (MEBT) is being assembled in a dedicated test stand for pre-commissioning with a proton beam. During 2011 extensive measurements were done after the source and after the LEBT with the aim of preparing the RFQ commissioning and validating the simulation tools, indispensable for future source upgrades. The measurements have been thoroughly simulated with a multi-particle code, including 2D magnetic field maps, error studies, steering studies and the generation of beam distribution from measurements. Emittance, acceptance and transmission measurements will be presented and compared to the results of the simulations.

reported in this paper. A sketch of the LEBT is shown in Fig. 1.

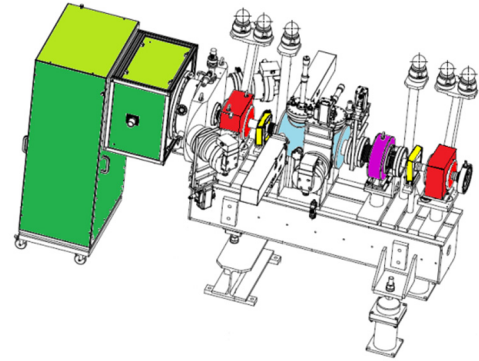

Figure 1: Sketch of the LEBT. In this scheme the source (green), solenoids (red), steerers (yellow), BCT (purple) and diagnostic tank (blue) are shown.

INTRODUCTION

The Low Energy Beam Transport (LEBT) of LINAC4 [1] is vital to control the current and emittance delivered to the RFQ. An extensive measurement campaign has been performed during 2011 with the aim of understanding the characteristics of the LEBT beam dynamics, discovering potential drawbacks in the design and validating the simulation models. The Linac4 ion source is in the process of being redesigned, and for these tests a proto-type version of the source was used in proton mode instead of the final H^- ion mode. Therefore, different neutralisation effects are expected. However, as the beam dynamics of the LEBT is charge insensitive, the measurement results are very useful for further studies.

LEBT LAYOUT

The LINAC4 Test Stand LEBT, 1.8m in length, consists of two solenoids, two steerers, a beam current transformer (BCT) and a special diagnostics vessel. Inside this vessel a Faraday cup, a profile monitor, a movable iris device and a pre-chopper are located. The layout was kept compact to minimise the detrimental effects of space charge at low energy (45keV). The two solenoids are used to focus and to match the beam to the RFQ, whereas the steerers are foreseen to optimise transmission in presence of alignment errors. During the Linac4 commissioning special test beams with reduced intensity and reduced emittance are foreseen, e.g. to inspect alignment errors. These beams will be generated by beam scraping using the iris aperture limitation. The pre-chopper is supposed to cut away the rising and falling edge of the beam and to help the action of the chopper at 3MeV. The pre-chopper was not operational during the measurement campaign

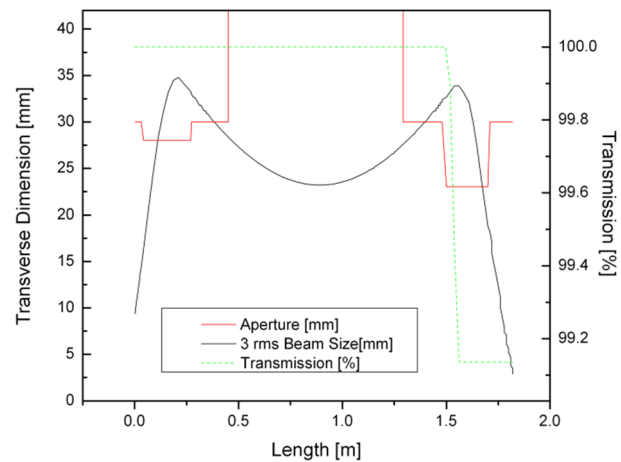

Figure 2: The transverse beam size, transmission and the aperture limitations along the LEBT. The aperture limitation and beam size is symmetrical in both transverse planes. The locations of the solenoids are marked by the reduced aperture limitations.

Fig.2 illustrates the LEBT beam dynamics, calculated with the code PATH [2], using the nominal beam parameters, i.e. 45keV, 80mA H^- ion beam with 90% space charge compensation. An uniform particle distribution was considered. These reference optics provide an almost lossless transmission through the LEBT within a good matching to the RFQ. Based on theoretical studies and experimental measurements it was concluded that the LEBT acceptance is determined by the distance between the source exit and the first solenoid as well as by the aperture of the first solenoid.

MEASUREMENTS

A slit-and-grid emittance measurement device and a Faraday cup were used to measure the beam emittance and intensity at 3 locations along the LEBT: 100mm downstream the source, 327mm downstream the first solenoid and 83mm downstream the RFQ matching plane.

After the Source

The beam-dynamics source-commissioning was focused on the investigation of the beam emittance and intensity at the source exit under varying source settings, with the hydrogen gas flow and source RF power being the most important factors. In Fig.3 a representative emittance is shown.

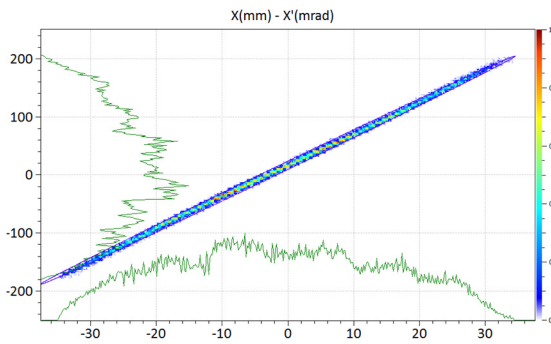

Figure 3: Measured emittance after the source, threshold 0.1‰ of the maximum signal. 40kW Source RF-Power was used to generate this beam configuration.

At the source exit the beam consists of protons (about 70%, measured with spectrometer line) as well as H_2^+ ions and H_3^+ ions, so the emittance surface is an upper limit. Also under varying source settings a symmetry of the two transverse beam planes is detected. These measured emittances are very reproducible. In order to generate a representative beam, which can be used for forward tracking simulations, several measurements were superimposed. In Tab.1 some sample source emittance parameters are reported. The expected parameters correspond to the data measured at DESY with 35keV H^+ ions, extrapolated to the same position.

Table 1: Beam Parameters at Source Exit

Parameter	Measured	Expected
Alpha (x,y)	-23.1,-23.6	-10.8, -10.8
Beta (x,y)	4.1m, 4.1m	0.9m, 0.9m
RMS Emittance (x,y)	0.43 mm mrad, 0.42 mm mrad	0.25 mm mrad, 0.25 mm mrad

The beam turned out to be considerably more divergent than expected with consequences on the transmission through the LEBT. The current measured after the source is reported in the section Beam Current Measurements.

After the First Solenoid

In a second phase the emittance meter and the Faraday Cup were mounted 330 mm downstream the first

solenoid. The measured phase space distributions are used to calibrate the solenoid field maps, generated with the code SUPERFISH/POISSON [3]. Due to the focusing effect of the solenoid the different species are separated in the phase space, which permits an effective cross check of the beam dynamics in the solenoid. In Fig.4 measured and simulated phase space distributions for three different solenoid1 settings are plotted.

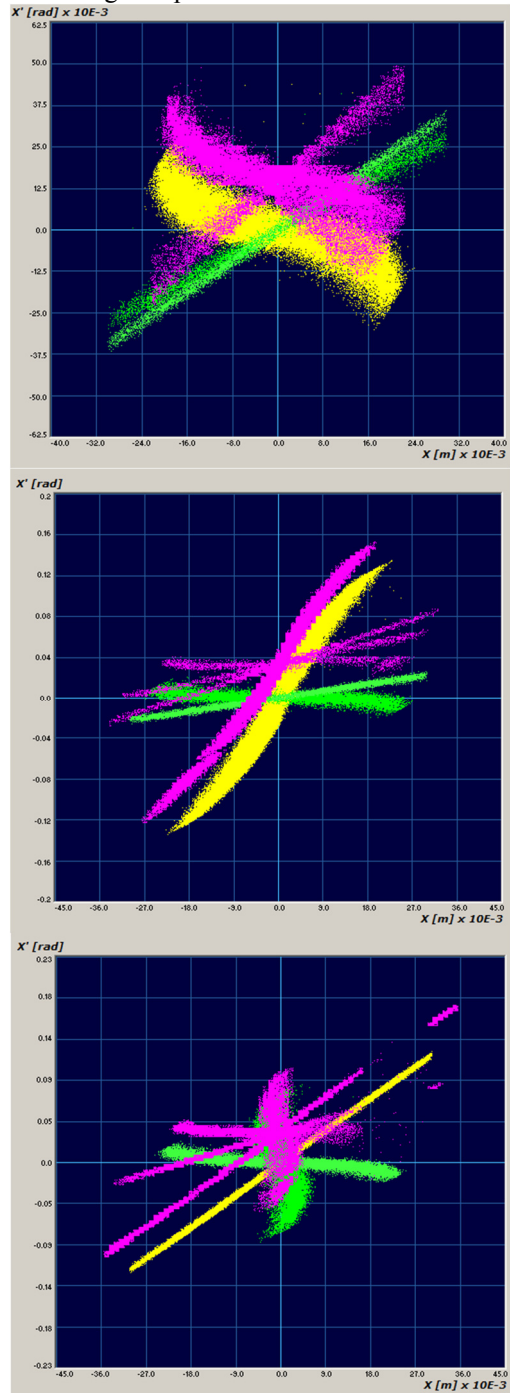

Figure 4: Measured (pink) and simulated emittance (protons yellow, H_2^+ ions and H_3^+ ions green) after the first solenoid. Solenoid settings top to bottom: 600,800 and 1000A (0.054, 0.072 and 0.09T m integrated field).

Copyright © 2012 by IEEE - cc Creative Commons Attribution 3.0 (CC BY 3.0) — cc Creative Commons Attribution 3.0 (CC BY 3.0)

The measured emittance is plotted in purple, whereas the simulated particle distributions are drawn in yellow and green. For sake of clarity of the plots, beam offsets have not been corrected in the measurements. The comparison of measurement results with simulation results demonstrates remarkably good agreement for all three particle species.

At the RFQ Matching Plane

The aim of the measurements after the second solenoid is to maximise the LEBT transmission within a good matching to the RFQ and to prove that enough flexibility to vary the matching conditions is present, if needed.

In Fig. 5 a measurement series is shown, at which the first solenoid current is maintained at 665A(0.06Tm) and the second solenoid current is varied from 300A to 400A (0.04Tm to 0.054Tm) in steps of 25A.

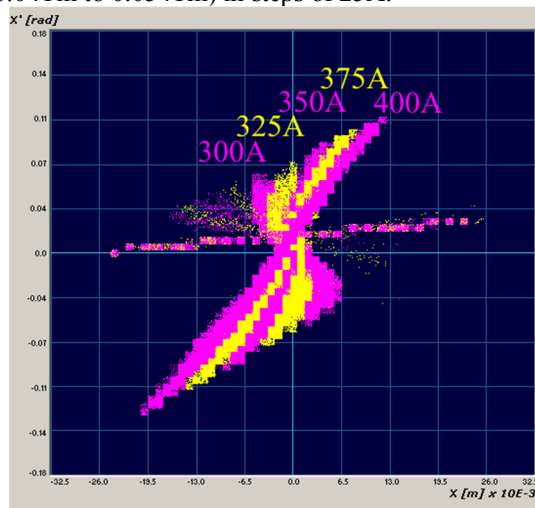

Figure 5: Measured emittance after the RFQ matching plane. The solenoid1 current is set to 665A and solenoid2 current is varied (300A,325A,350A,375A,400A).

Based on the measurement results it could be concluded that the Twiss parameters are adaptable in a wide range. Moreover, a very good agreement between measurement results and simulations results was obtained.

Beam Current Measurements

The measurement of the beam current at different locations is essential to identify drawbacks, which can reduce the beam transmission. Beam current measurements were performed at the source exit, between the solenoids, Faraday Cup1, and about 110mm downstream the RFQ matching plane, Faraday Cup2.

At the source exit the proton beam current is superimposed with the beam current of H₂⁺ ions and H₃⁺ ions. The ratio of the species depends on to the LEBT settings and on the measurement position.

During source commissioning the beam current output was investigated under varying source conditions, e.g. RF power and hydrogen gas flux. In Fig. 6 a measurement series is plotted, at which the beam current was measured depending on the RF power with a maintained hydrogen gas flux. The beam current after the source depends

almost linearly on the source RF power. However, a significant increase of the beam current is associated with a significant increase of the transverse emittance.

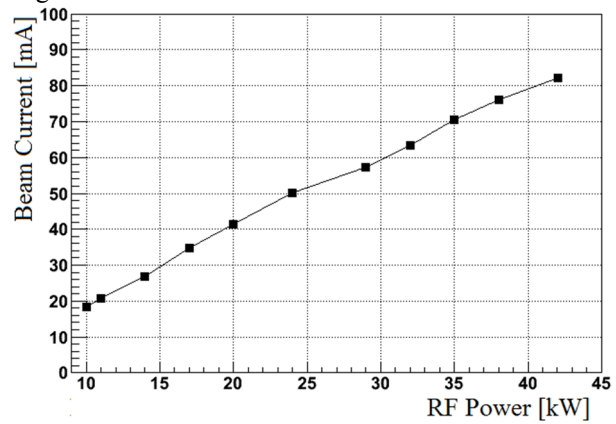

Figure 6: Measured Beam Current at the Source exit. This beam current corresponds to the total beam current.

Based on the source measurements detailed studies of the LEBT optics were performed and a good agreement between LEBT measurements and simulations also in terms of transmission was obtained. In Fig.7 beam current measurements at Faraday Cup2 and the theoretical LEBT transmission are plotted.

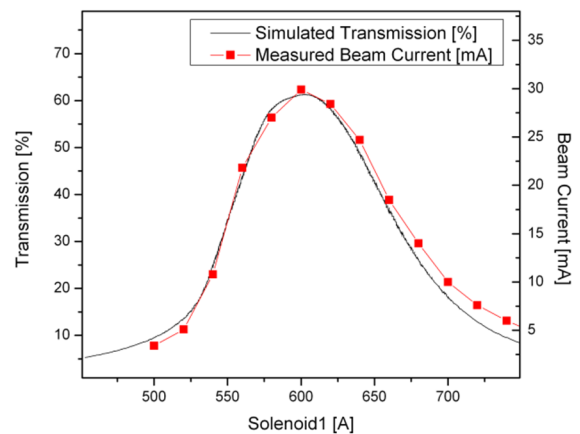

Figure 7: Measured beam current and simulated LEBT transmission. The measured beam current agrees well with the theoretical LEBT transmission.

A maximum proton beam current of 30 mA was successfully transported and matched to the RFQ. The expected transmission through the RFQ of the measured beam is 80%.

The detailed investigation of the LEBT optics and the comparison between simulations results and measurements are reported in [4].

REFERENCES

- [1] L. Arnaudon, et al. Linac4 technical design report. Technical Report CERN-AB-2006-084, CERN (2006).
- [2] A.Perrin,J.F.Amand,Travelv4.06user manual, CERN(2003).
- [3] J. Billen and L. Young, "SUPERFISH/POISSON Manual" LA-UR-96-1834
- [4] PhD. Thesis, Lutz Matthias Hein, to be published.