

LOW ENERGY ION INJECTOR AT KACST

M. El Ghazaly, A.A. Almukhem, A. Mandil, KACST, Riyadh, Saudi Arabia
 A. Papash, MPI for Nuclear Physics, Heidelberg Germany and JINR, Russia (on leave)
 C.P. Welsch, Cockcroft Institute and University of Liverpool, UK

Abstract

At the National Centre for Mathematics and Physics (NCMP), at the King Abdulaziz City for Science and Technology (KACST), Saudi Arabia, a versatile low energy ion injector was developed in collaboration with the QUASAR group. This project will allow for a broad experimental program with most different kinds of ions both in single pass setups, but also with ions stored in a fixed-energy electrostatic storage ring. In this contribution, the design of the injector is presented. It was designed for beams with energies of up to 30 kV/q and will allow for switching between different ion sources from e.g. duoplasmatron to electrospray ion sources and to thus provide the users with a wide range of different beams. The mechanical construction of the injector is summarized and the status of its assembly at KACST presented.

INTRODUCTION

Beams of low-energy ions are highly interesting for a number of different fields, in particular for biophysics, chemistry, nanotechnology, and molecular physics, i.e. life sciences in general. When stored in a storage ring, these beams can be manipulated in various ways and be used for e.g. crossed and merged beam experiments, collision studies, or life time studies of instable ions.

At very low energies, electrostatic storage rings have clear advantages over their magnetic counterparts. In particular the mass-independence of the electric rigidity $E\rho = E_{kin}/q$, where E is the electric field ρ the radius of curvature, E_{kin} the ion's kinetic energy and q its charge state allows for e.g. storing singly charged biomolecules with very high molecular masses in the same field configuration as protons having the same kinetic energy. Three of these machines are already in operation [1-3], two cryogenic [4,5] and one room temperature storage ring [6] are being built up, and an energy variable ring will be the central machine of the FLAIR facility in Germany [7].

In addition to these machines, a fixed-energy electrostatic machine that will store ions up to 30 keV/q has been designed and is presently being constructed at KACST [8,9].

INJECTOR DESIGN

As pointed out in the introduction, a key advantage of electrostatic storage rings is their ability to store ions irrespective of their mass. This can only be fully exploited if the injector provides a wide range of different beams so that a broad experimental spectrum can be covered.

An overview of the injector is shown in the Fig. 1. Over a total length of 3316 mm the beam is extracted from the ion source, before being focused by an Einzellens and finally being shaped and matched to the injection point in the storage ring by two electrostatic quadrupole doublets and several sets of electrostatic steerers (not shown in the figure).

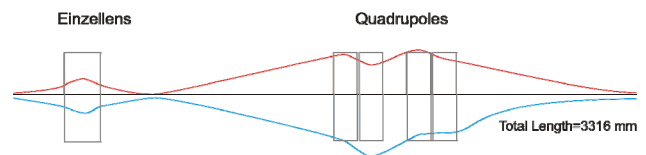

Figure 1: Overview of the injection beam line including the set of four quadrupoles.

An upgrade of the injector is already planned and will consist of the addition of a 90° analyzing spectrometer magnet with +26.6° pole faces and a high mass resolution. This magnet will help improving the output beam intensity and quality.

In addition, it is planned to subsequently add several ion sources, as well as a chopper to modify the longitudinal bunch structure before injection into the storage ring.

Beam Generation

A simple, yet quite effective, production method of ions consists of inducing an electrical discharge in a gas, which will create high concentrations of ionized species that can be extracted from the discharge volume by the application of electromagnetic fields. This principle is implemented in a particularly simple ion source, the so-called Cold Cathode Ion Source (CCIS). Contrary to e.g. the sputter source, the CCIS does not contain a heated filament, and the absence of this allows the source to function at somewhat lower than those of the sputter source, hence the name.

This principle has been successfully applied and adopted so far in many laboratories of Plasma and Atomic physics worldwide. In collaboration, with the University of Aarhus, a small glass cathode ion source was built to generate both negative and positive ions. The design principles used follow closely an existing and well characterized source at U Aarhus, but many practical aspects, concerning the connections, feed-throughs, gas inlet, etc were improved.

The CCIS is a hollow-cathode glow discharge source, which consists of a glass cylinder closed on one end. Inside the cylinder two cylindrical stainless steel electrodes are mounted that are electrically isolated from each other. Both are connected with electrodes leading

through the glass cylinder to an external current supply. At the open end of the glass cylinder, a stainless steel plate separates the high-pressure ion source from the vacuum of the accelerator onto which the source is mounted. A small orifice (~0.5 mm) allows for the extraction of ions produced in the discharge between the electrodes.

The source is evacuated and a controlled partial pressure of a desired gas can be supplied through a needle valve. A discharge voltage of typically up to 600 V, applied across the two electrodes, will cause free electrons to accelerate towards the anode, creating electron-ion pairs on their way through collisions with neutrals. The ions generated this way will travel in the opposite direction, bombarding the cathode and thereby cause new electrons to be emitted. If the generation of electron-ion pairs is sufficient to make up for the loss of charged particles to the electrodes and to the chamber walls, a stable plasma is formed.

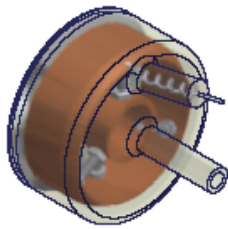

Figure 2: Design drawing of the cold cathode ion source (CCIS).

Depending on what kind of ions will be extracted at a specific energy from the source, beam extraction will be optimized by a laterally movable electrode which also forms the first grounded electrode of the Einzellens. The detailed design of the ion extraction system was already described in [10].

Einzellens

Immediately after the ion source, an electrostatic Einzellens with two grounded electrodes and a central cylindrical electrode at voltage V will be used to radially focus the ion beam.



Figure 3: Photograph of the manufacturing of the movable electrode of the Einzellens.

The design parameters of the Einzellens are summarized in the following Table 1.

Table 1: Design parameter of the Einzellens.

Parameter	Value
Inner diameter [mm]	40
Length of central electrode [mm]	40
Gaps [mm]	10
Acceptance of Einzellens [π mm mrad]	120
Voltage on central electrode [kV]	16.0

Electrostatic Quadrupoles

All ion optical elements for the injector and the electrostatic storage ring at KACSR were developed in parallel. This allows for utilizing similar mechanical designs, power supplies, and control systems for all components, and will thus help reducing the overall construction time.

The parameters of the quadrupoles, that will be used for beam focusing, are summarized in Table 2.

Table 2: Design parameter of a quadrupole doublet.

Parameter	Value
Electrode Length [mm]	100
Radius of curvature [mm]	28.7
Aperture radius [mm]	25
Distance electrode-shield [mm]	15
Thickness of shield [mm]	3
Voltage on quadrupoles [kV]	± 5

Beam Steering

The horizontal and vertical position of the beam will be controlled by parallel plate deflectors. A total number of three pairs of deflectors will be initially installed in the injector. One directly behind the Einzellens and one in front of and behind the quadrupole doublets to control any potential misalignment and to ensure that the beam passes centrally through the quadrupoles.

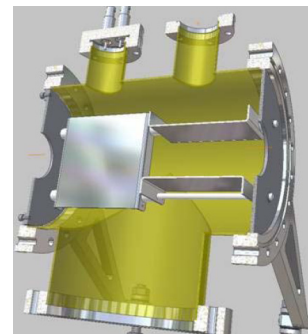

Figure 4: Beam steerers in the low injector.

The electrodes will be housed in a vacuum chamber with a radius of 150 mm and plates will be positioned at a distance of 50 mm. Each electrode has an area of 100 x 100 mm² and a distance of 7 mm to the 3mm thick shields. A 3D drawing of the electrodes is shown in Fig. 4

The combination of two quadrupole doublets with two sets of beam steerers will allow for matching beams from

different ion sources efficiently into the electrostatic ring. Both the beam shape and its position can be controlled over a wide parameter range thus allowing for maximizing the experimental output. An overview of the full injector and the storage ring is depicted in Fig. 5.

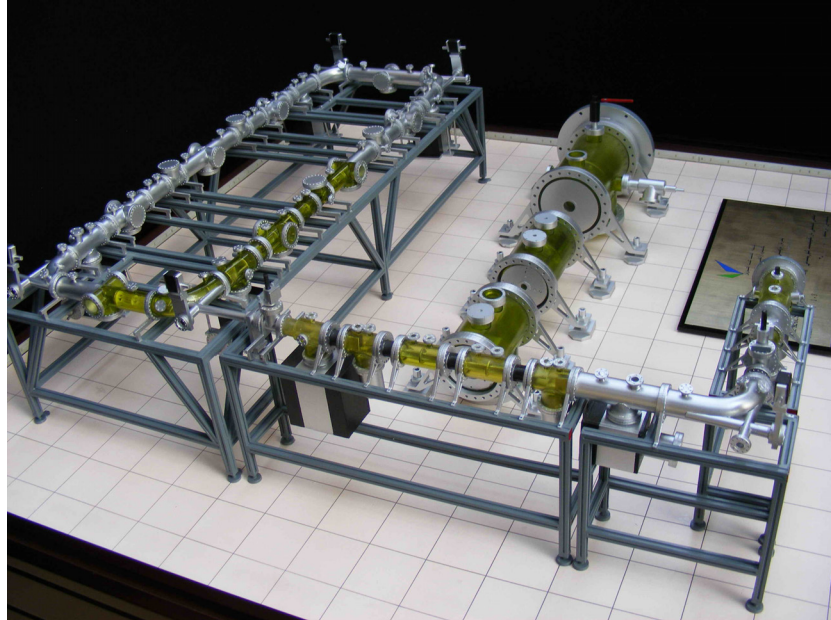

Figure 5: Illustration of the low energy complex at KACST.

CONCLUSION AND OUTLOOK

The particle optical and mechanical design of a new ion injector at KACST was presented in this contribution. The ion beam generation in a CCIS was described and all steering and focusing elements were presented. The injector will provide beams of low energy ions to an electrostatic storage ring that was developed in parallel to it. All elements have been manufactured and were shipped to KACST. The injector will be assembled in 2010 and commissioned before the end of the year.

ACKNOWLEDGEMENT

The help of Henrik Juul (U Aarhus, Denmark) during the design process is acknowledged.

REFERENCES

- [1] S.P. Moeller, ELISA - an Electrostatic Storage Ring for Atomic Physics, Proc. European Part. Acc. Conf., Stockholm, Schweden (1998)
- [2] T. Tanabe et al., An Electrostatic Storage Ring for Atomic and Molecular Science, Nucl. Instr. And Meth. A **482** (2002) 595c
- [3] S. Jinno et al., TMU electrostatic ion storage ring designed for operation at liquid nitrogen temperature, Nucl. Instr. and Meth. A **532** (2004) 477c
- [4] D. Zajfman et al, "Physics with colder molecular ions: The Heidelberg Cryogenic Storage Ring CSR", J. Phys. Conf. Ser. **4** (2005) 296c
- [5] K.-G. Rensfelt et al., DESIREE - a Double Electrostatic Storage Ring, Proc. European Part. Acc. Conf., Lucerne, Switzerland (2004)
- [6] C.P. Welsch et al., An Electrostatic Storage Ring as the Central Machine of the Frankfurt Ion Storage Experiments, PRST-AB **7**, 080101 (2004)
- [7] K.E. Stiebing et al., "FLSR - The Frankfurt low energy storage ring", Nucl. Instr. Meth. A **614**, 10-16, 2010
- [8] M.A. El Ghazaly et al., "Layout of a Novel Electrostatic Storage Ring at KACST", Applied Mathematics & Information Sciences **3** (3) (2009), 309-319
- [9] M.A. El Ghazaly et al., "Layout of an electrostatic storage ring at KACSR", Proc. Part. Acc. Conf., Vancouver, Canada, 2009
- [10] M.A. El Ghazaly et al., "Design of a versatile injector for a low-energy experimental platform at KACST", Proc. Europ. Part. Acc. Conf, Genoa, Italy (2008)