

# SYSTEM OVERVIEW AND DESIGN CONSIDERATIONS OF THE BPM SYSTEM OF THE ESS LINAC

H. Hassanzadegan, A. Jansson, A. J. Johansson, R. Zeng, ESS AB, Lund, Sweden  
 K. Strniša, Cosylab, Ljubljana, Slovenia  
 A. Young, SLAC, Menlo Park, California

## Abstract

The ESS Linac will include in total more than 140 Beam Position Monitors of different sizes and types. The BPM system needs to measure the beam position, phase and intensity in all foreseen beam modes with a pulse rate of 14 Hz, duration of 2.86 ms and amplitude ranging from 5 mA to 62.5 mA. With respect to the BPM connection to the Machine Interlock System, the total response time must be less than 10  $\mu$ s. The signal level variations from one BPM to another along the Linac should be as small as possible to meet the requirements on the analog gain of the front-end electronics and the dynamic range of the digitizer card input. The other requirement is that the BPM system needs to give at least a rough estimation of the beam position and phase, even if the beam is significantly debunched, ex. during the Linac tuning phase. These requirements and their impact on the design of the BPM detector, the analog front-end electronics and the selection of the digitizer card are discussed in this paper along with a general description of the BPM system.

## BPM SYSTEM OVERVIEW

The ESS Linac will include in total more than 140 BPMs (Beam Position Monitors) of different sizes and types. Most of the BPMs will be mounted and centered in the quadrupole magnets. Furthermore, 6 BPMs with a special design are foreseen for the MEBT (Medium Energy Beam Transport), 8 compact-size BPMs for the DTL (Drift Tube Linac) and a few wide-aperture BPMs for the Target monolith. Table 1 summarizes the main parameters of the ESS beam and the BPM specifications.

According to the current design, most of the BPMs will be electrostatic button type with a modified version of the European XFEL (X-ray Free Electron Laser) button style design. The exceptions are the DTL BPMs, which will be stripline, and the target monolith BPMs, where conventional button BPMs may not have the required performance; therefore another BPM type might be used.

The BPMs will measure the beam position and phase as well as a rough estimation of the beam intensity. The position measurement will be used for the purpose of beam diagnostics and providing input to the BIS (Beam Interlock System), while the phase measurement is mainly intended for RF tuning and time-of-flight energy measurements.

One of the requirements of the ESS BPM system is that it should be able to measure position and phase of a de-bunched beam. This is particularly important during Linac commissioning when an RF cavity is being tuned

while all downstream cavities are unpowered, resulting in a significant bunch length growth before the beam is dumped. As the beam gets de-bunched, the S/N (Signal-to-Noise) ratio of the BPM signal will degrade resulting in a less accurate measurement. Nonetheless, in this condition, it is still necessary to know the beam phase and position to tune downstream cavities and ensure that the beam does not deviate from its foreseen path.

It is planned to use a rastering system upstream of the target station to uniformly enlarge the interaction area of the beam with the tungsten target, thus avoiding damages and increasing the operational life of the target wheel. The rastering system will move the beam horizontally and vertically so that the beam sweeps a rectangular area on the target wheel in a cycle before starting a new one. It is foreseen to use a few BPMs in the target monolith to monitor the beam deflection. The associated electronics of these BPMs need to do some additional processing to ensure that the beam follows the foreseen path and shut the beam off if the deviation of the actual position from the expected one exceeds a limit. A few requirements should be considered in the design of these BPMs, being a low signal level due to high beam velocity and large aperture, a fast response and an augmented robustness level to work reliably under high radiation.

Table 1: ESS Beam Parameters and BPM Specification

Parameter	Value	Unit
<b>Beam</b>		
Max Energy	2	GeV
Pulse repetition rate	14	Hz
Pulse duration	2.86	ms
Max pulse current (nominal)	62.5	mA
Longitudinal bunch size ( $1\sigma$ )	2-3	mm
RF frequency	352, 704	MHz
<b>BPM detector and electronics</b>		
Position measurement accuracy (rms)	100	$\mu$ m
Position measurement resolution	20	$\mu$ m
Phase measurement accuracy (rms)	1	$^\circ$
Phase measurement resolution	0.2	$^\circ$
Phase measurement range	$\pm 180$	$^\circ$
Beam pipe diameter	60, 100	mm
Measurement radius w.r.t. beam pipe	50	%
BPM cable length	$\sim 60$	m
Electronics response time	1-2	$\mu$ s
ADC sample rate	50-100	MSa/s
ADC bit number	16	bits

The amplitude of the signal induced in a BPM button is a function of several parameters including beam velocity,

button size and beam pipe diameter. As these parameters vary substantially from the beginning to the end of the ESS Linac, the frontend electronics needs to include an adjustable amplifier/attenuator stage to equalize the amplitude of the BPM signals, so that the full dynamic range of the ADC input can be utilized.

It is planned to use a custom analogue front-end and a commercial digitizer module for the implementation of the BPM low-level electronics. In the analogue front-end, either the 352 MHz or the 704 MHz harmonic of the BPM signals will be picked up by some low-noise electronics. The BPM signals will be level-adjusted, down-converted, filtered and conditioned before being fed into the digitizer module. The signals will then be sampled and fed into an FPGA for the required digital signal processing including position, phase and intensity calculations, linearization, interfacing to the control system, memory read/write etc.

### BPM VOLTAGE CALCULATIONS

The voltage induced on a BPM button can be calculated by multiplying the beam image current flowing through the button by the button impedance [1]. The button impedance is the parallel combination of the characteristic impedance of the BPM cable and the parasitic capacitance of the button. At several hundred MHz, capacitances as low as a few pF can significantly reduce the overall button impedance, resulting in a low BPM voltage. Therefore, for the ESS BPMs, the aim is to use buttons with a large gap (similar to the XFEL design) to minimize the parasitic capacitance and get enough voltage out of the button.

Calculations show that with a centered beam, the voltage induced on the BPM buttons ranges from less than 100 mV up to several hundred mV depending on the beam velocity and the beam pipe diameter (see Fig. 1). Also, the electrode voltage changes significantly as the beam moves transversally within the beam pipe. Considering a measurement radius of half the beam pipe radius, cable length of 60 m and final beam energy of 2 GeV, an amplification factor of about 16 dB will be needed to utilize the full  $\pm 1$  V<sub>pp</sub> dynamic range of the ADC input. In the low-energy part of the Linac, the signal level will be much higher due to the low beam velocity and smaller aperture, and the BPM signal should be attenuated by as much as 14 dB in order not to saturate the ADC input.

The total noise acting on the BPM signal has been calculated as the sum of the thermal noise and the effective input noise of the front-end electronics. Assuming an analogue bandwidth of 10 MHz and an effective input noise of 10  $\mu$ V (rms) for the RTM, at the maximum beam energy, the resultant S/N ratio at the ADC input is equivalent to about 23  $\mu$ m, slightly exceeding the required BPM resolution. In practice, however, the S/N ratio can be lower due to other noise sources not taken into account in the calculations. Therefore, some digital filtering might be needed to meet

the specifications. At lower energies, the S/N ratio is higher, resulting in a better BPM resolution.

As the amplitude of the BPM voltage is relatively low at high beam velocities, larger buttons with a diameter of 25 mm and above are foreseen for the high-energy part of the Linac.

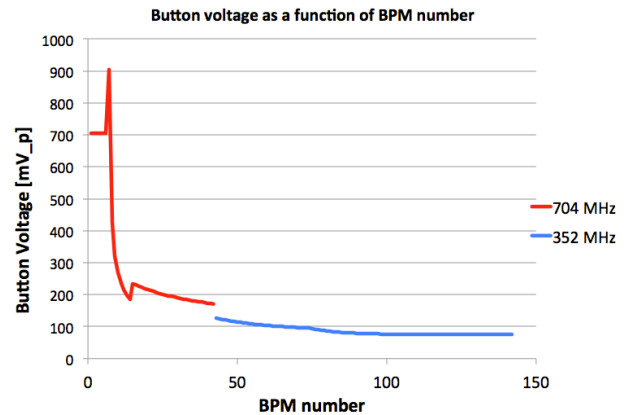

Figure 1: Calculated BPM signal level along the Linac as a function of BPM number. The exponential-like decay is due to the increase of the beam velocity and the sharp changes are due to differences of the beam pipe diameter and the button size.

### BEAM DEBUNCHING

The ESS BPM system needs to give at least a rough estimation of the position/phase of a debunched beam. This will be required, for example, during a cavity phase scan while the beam is being sent to the nearest beam dump. As in this case, all downstream cavities will be unpowered, the beam can become significantly debunched in the longitudinal direction. Nonetheless, it is important to know the beam phase and position to tune downstream cavities and dump the beam without facing a risk of damage to the Linac components. Fig. 2 shows the simulated longitudinal beam size growth with no powered cavity after the spokes section.

As the bunch length gets larger, the 352 MHz and 704 MHz harmonics of the electrode signal become weaker, degrading the S/N ratio and the BPM resolution. The distance over which the beam is debunched can be as large as a few hundred meters and the bunch length can grow to 400 mm and above. In this condition, the beam current will be almost DC due to the large overlap of successive bunches, resulting in very small 352 MHz and 704 MHz components of the BPM signal. Calculations show that the BPM resolution will degrade by more than one order of magnitude if the bunch length changes from the nominal 2-3 mm to 170 mm [2]. The situation will get even worse if the beam current is decreased, for example in the diagnostics beam mode. That, at some point, may even make it impossible to measure the beam position/phase as the BPM signal cannot be distinguished from noise.

In order to make sure that the BPM system will be able to measure the beam position and phase in all foreseen beam modes, it is important to ensure that the amplitude of the first and the second harmonic is large enough so that it can be sampled satisfying a minimum S/N ratio.

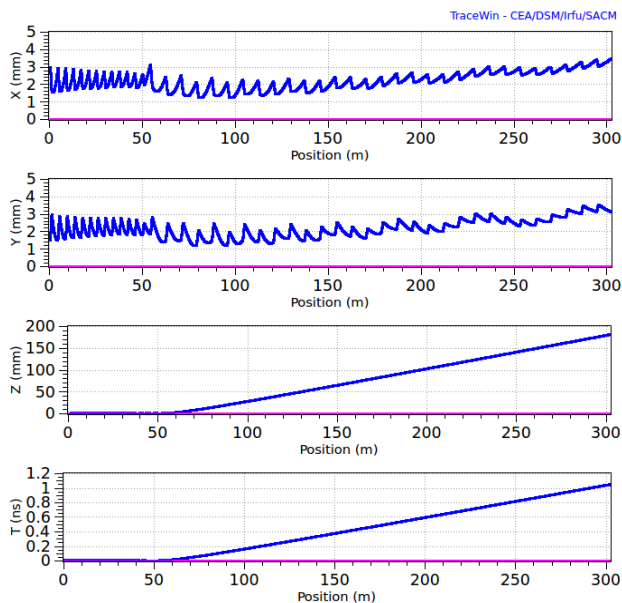

Figure 2: Simulated bunch size along the x, y, z and time axis with no powered cavity after the spokes. Courtesy of Ryoichi Miyamoto (ESS Beam Dynamics group).

## BPMs FOR THE RASTERING SYSTEM

In order to avoid damages to the target wheel and increase its operational life, a series of quadrupole magnets combined with a rastering system will be used to uniformly enlarge the area where the proton beam hits the tungsten target [3]. The rastering system will move the beam horizontally and vertically so that it paints a rectangular area on the target wheel, thus spreading the power over a larger area.

Beam deflection will be done by two sets of horizontal and vertical dipole magnets powered by some ramping power supplies. The horizontal and vertical movements will be synchronized with each other so that the beam does not hit a single point on the target wheel more than once during a complete sweep.

It is foreseen to use two BPMs in the target monolith for the rastering system; one upstream and one downstream of the proton window right before the target wheel. These BPMs will be used to measure the beam deviation from its expected path and send a beam abort request to the BIS if the deviation exceeds a certain threshold, ex. due to a failure of the magnet power supply. The BIS will then shut the beam off to avoid damages to the target monolith or the upstream Linac components.

According to the current design, the BPMs of the rastering system need to measure the beam position within a large aperture of about 160 mm by 60 mm with a time resolution of 1  $\mu$ s and accuracy of 1 mm. The total

response time for acting on the BIS system should not exceed 100  $\mu$ s. As these BPMs will be installed close to the target wheel, they need to work reliably under high radiation levels in addition to having a small size due to the limited space in the target monolith.

Meeting these requirements simultaneously can be challenging with the current design of the BPM system. The 1  $\mu$ s acquisition time is about the fastest response time that can be achieved with the currently-planned BPM electronics. On the other hand, meeting the 1 mm accuracy might be difficult due to the degraded S/N ratio caused by the high beam velocity, large aperture and significant BPM non-linearity with an off-centered beam. For those reasons, it may become necessary to use a different BPM type for the rastering system, or relax the rastering requirements.

## BPM ELECTRONICS

In the BPM electronics, either the 352 MHz or the 704 MHz harmonic of the BPM voltage will be processed to calculate the beam position and phase. The processed frequency will be opposite to RF to minimize potential disturbances from nearby RF sources. The BPM electronics will be based on a custom analogue front-end connected to a commercial digitizer module. MTCA.4 (Telecommunication Computing Architecture for Physics Research) standard is currently planned for the implementation of the electronics.

Two options are currently under investigation for the detection of the BPM signals, being 1) sampling directly in RF and 2) sampling after down-mixing to IF. One of these methods or both will be used later on after their performances have been checked in practice.

It is planned to develop a new RTM (Rear Transition Module) through external collaborations for the detection of the BPM signal with a potential use for the LLRF (Low Level Radio Frequency) system as well. In order to meet the requirements on the BPM resolution and the fast response time, a 16-bit ADC with a sampling frequency more than 100 MSa/s will be used in combination with high FPGA processing power for the required digital signal processing. A prototype MTCA.4 crate (see Fig. 3) including a commercial RTM and AMC (Advanced Mezzanine Card) has already been procured and successfully tested at low RF frequencies.

A BPM test bench has been designed and will be used later on for testing the electronics and the BPM detector.

The timing and synchronization signals required for the BPM system includes a 352 MHz RF phase reference, an ADC clock synchronized to RF, and a 14 Hz trigger for the synchronization of the data acquisition to the Linac repetition rate. Implementation details of these signals are currently under discussion with the RF group and the ICS (Integrated Control System) division.

Also, a digital interface to the BIS is being discussed with the MPS (Machine Protection System) group to shut the beam off within 10  $\mu$ s in case a fault has been detected by the BPM system.

The BPM electronics will be integrated into EPICS (Experimental Physics and Industrial Control System). A preliminary version of the required software including a user-space driver for the digitizer card, an EPICS application and a GUI (Graphical User Interface) has been prepared by Cosylab and tested on the prototype MTCA.4 system with promising results.

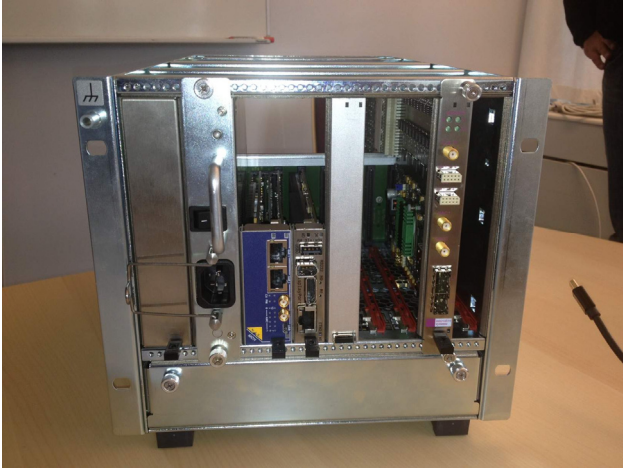

Figure 3: Picture of the prototype MTCA.4 system.

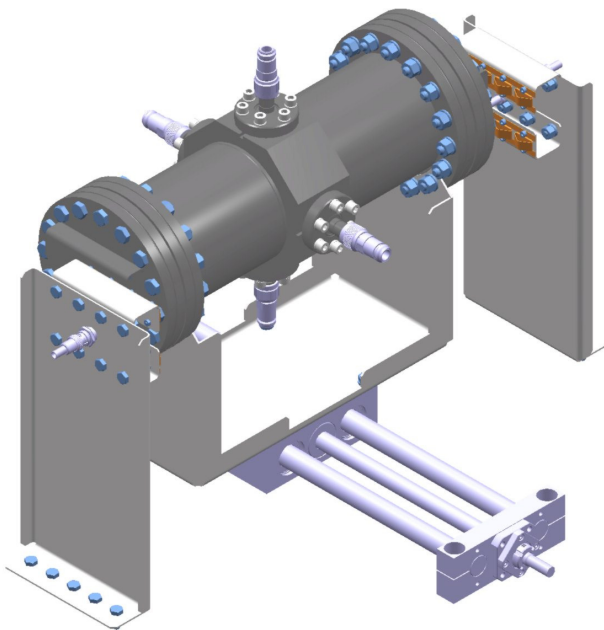

Figure 4: Layout of the BPM test bench. Courtesy of Mikael Puls (ESS).

### SUMMARY

The ESS Linac will include in total more than 140 BPMs of various sizes and types. The BPMs will be mostly button type and will be mounted and centered in the quadrupole magnets. Several requirements have to be fulfilled in the design of the BPM detectors and the low-level electronics, being equalization of the BPM voltages along the Linac, position/phase measurement of a debunched beam as well as a fast response and a wide aperture in particular for the rastering system. Meeting these requirements needs a careful design of the BPM detector and the front-end electronics. It is planned to use a custom analogue front-end combined with a commercial digitizer to detect the BPM signals and digitally process them for position, phase and intensity measurements. MTCA.4 standard is planned for the implementation of the electronics. A prototype MTCA.4 system has already been procured and successfully tested through external collaborations.

### REFERENCES

- [1] R. E. Shafer, "Beam Position Monitoring", Los Alamos National Lab., (1990).
- [2] H. Hassanzadegan, A. Jansson, A. J. Johansson, "Beam Position Monitor System of the ESS Linac", MOP238, Proc. HB2012, Beijing, (2012).
- [3] Thomas Shea *et. al.*, "Proton Beam Measurement Strategy for the 5 MW European Spallation Source Target", TUPC02.