

# The SPES Project: research and development for the multi-foil direct target

M. Manzolaro<sup>1,3</sup>, A. Andrichetto<sup>1</sup>, L. Biassetto<sup>1,2</sup>, G. Meneghetti<sup>3</sup>, S. Carturan<sup>1</sup>, D. Scarpa<sup>1</sup>, P. Colombo<sup>2</sup>, G. Prete<sup>1</sup>

1. INFN, Laboratori Nazionali di Legnaro, Viale dell'Università 2, 35020 Legnaro (Pd), Italy.
2. Università di Padova, Dipartimento di Ingegneria Meccanica, - sezione materiali - Via Marzolo. 9 - 35131 Padova, Italy
3. Università di Padova, Dipartimento di Ingegneria Meccanica, Via Venezia 1, 35131 Padova, Italy
4. Università di Padova, Dipartimento di Scienze Chimiche, Via Marzolo 1 - 35131 Padova, Italy

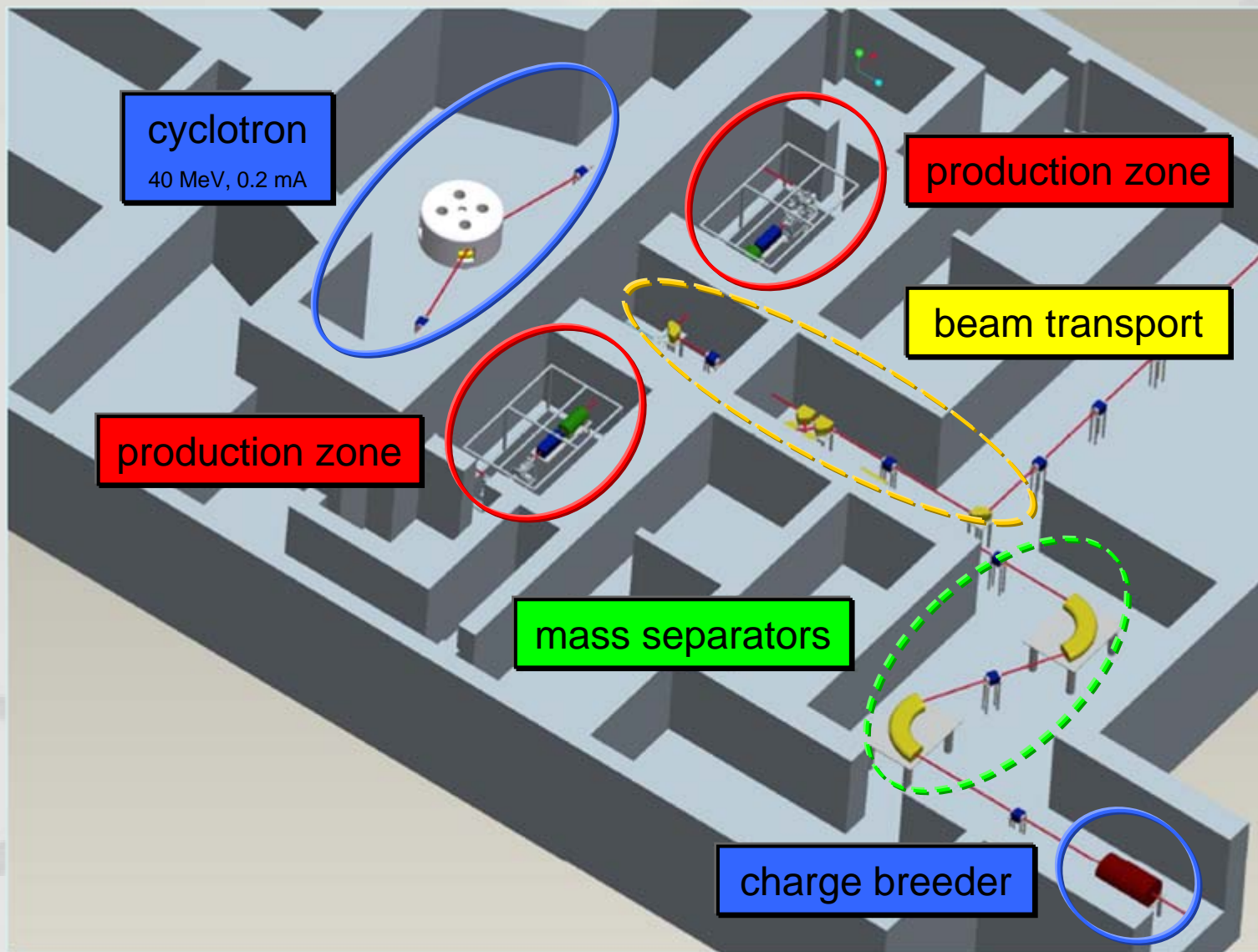



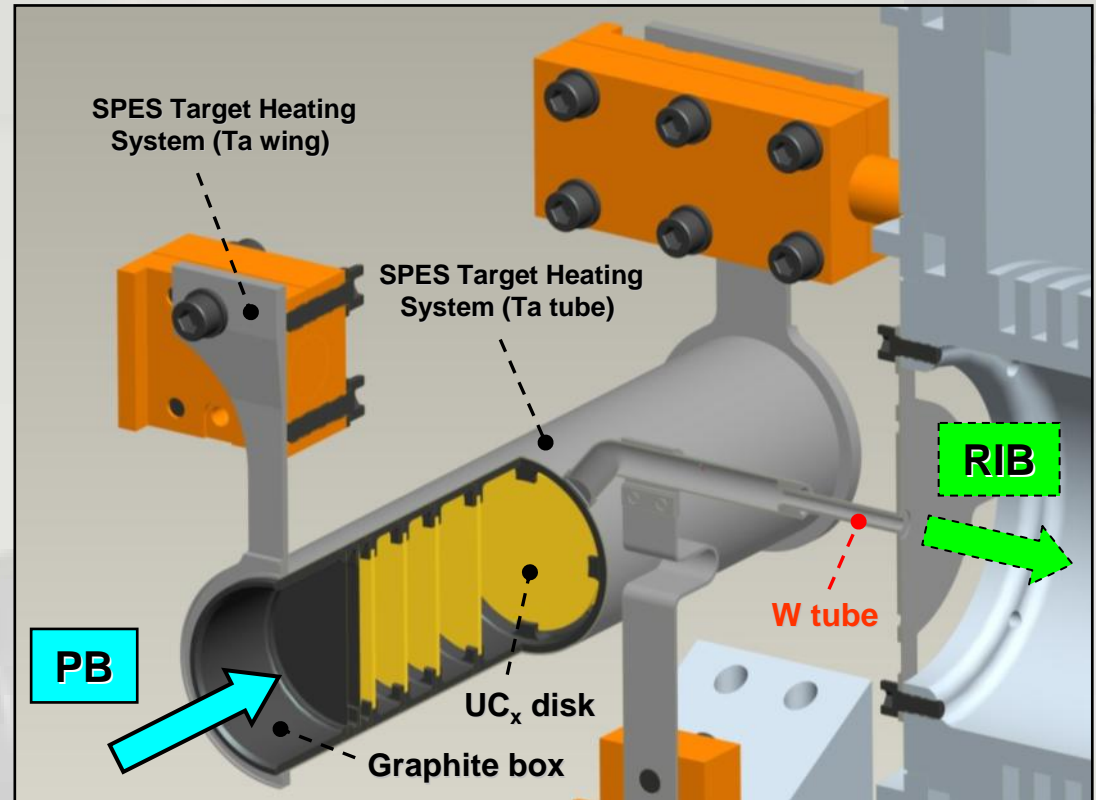
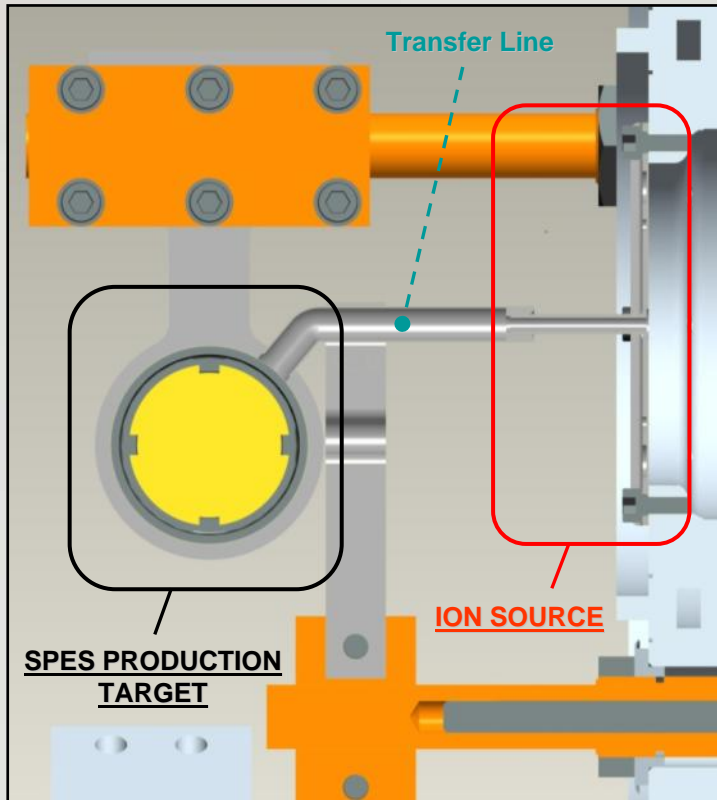

## SPES PRODUCTION TARGET

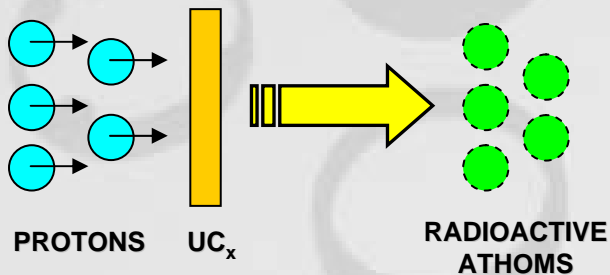

## Transfer Line

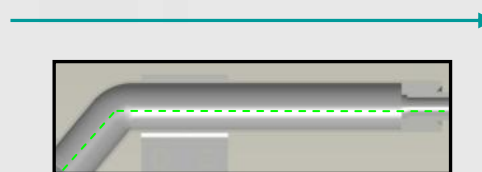

## ION SOURCE

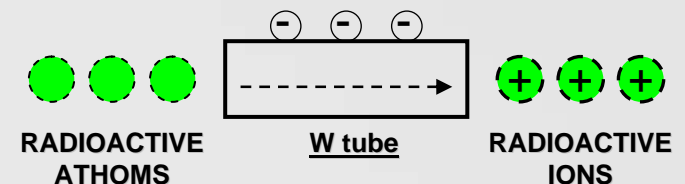

## WG1: Mechanical Development (LNL)

- Thermo-Mechanical Calculations
- Development of target prototypes
- CAD mechanical drawings

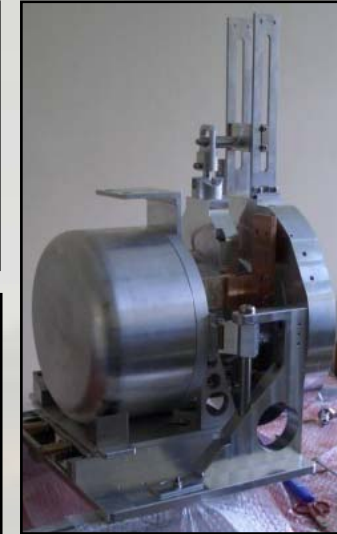
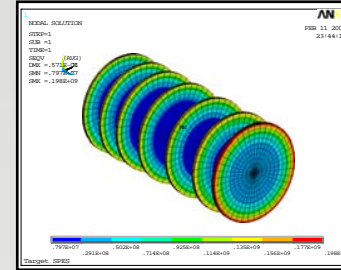
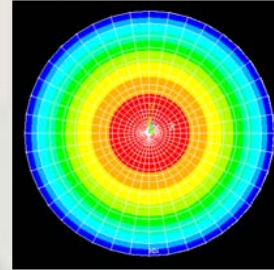

## WG2: Material Development (LNL)

- Carbide productions
- Carbide characterizations
- New porous material
- New characterization methods

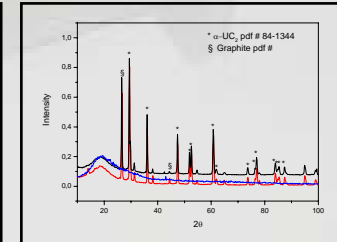
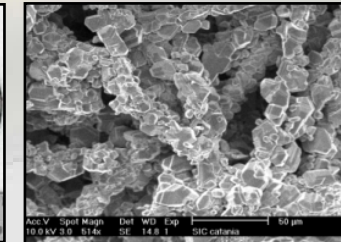
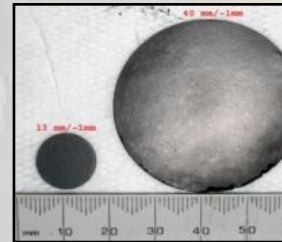
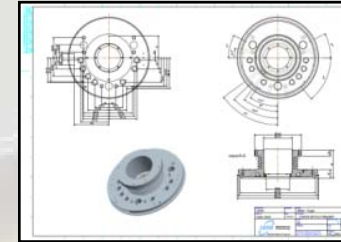

## WG3: Ion Source Development (INFN-PV)

- Laser & Ion source developments

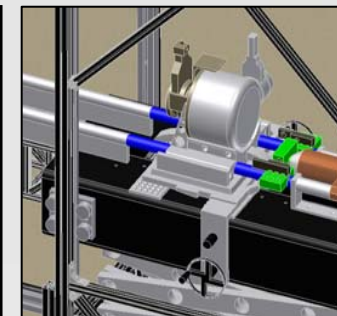
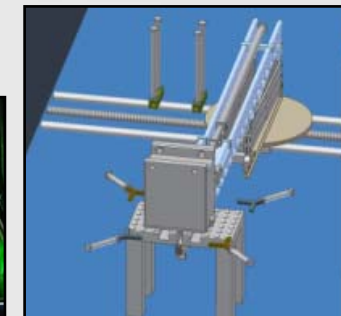

## WG4: Handling (INFN-BO)

- Target handling & controls

# WG1

# Mechanical Developments

# The SPES target prototype

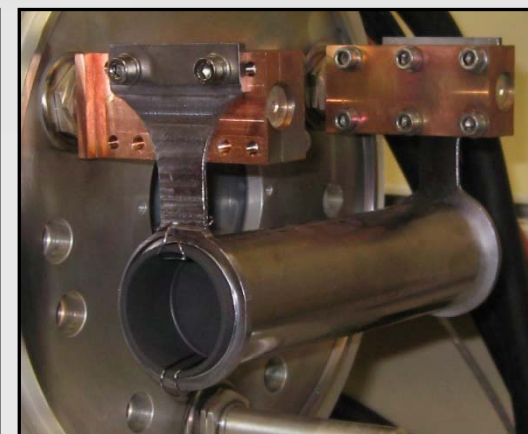
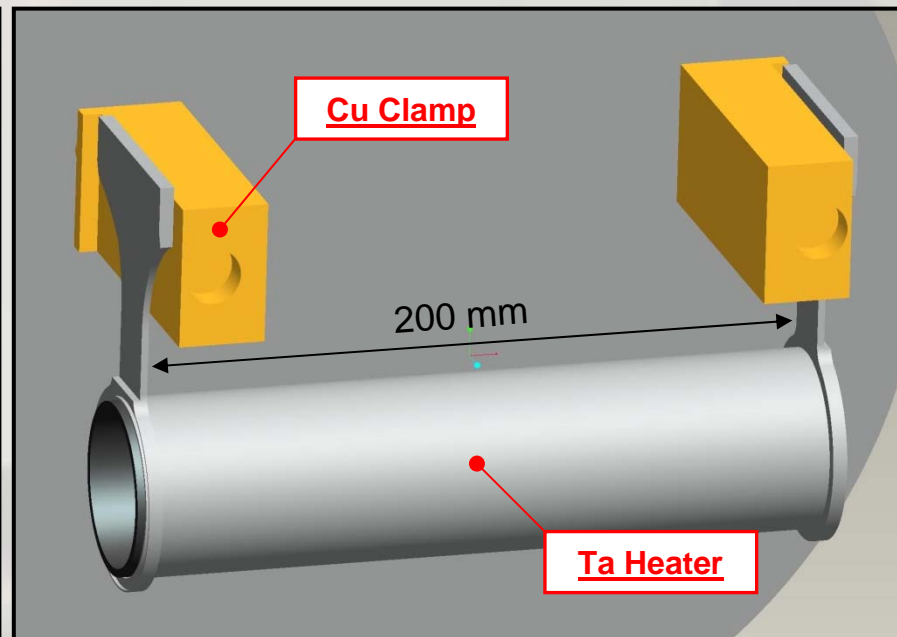
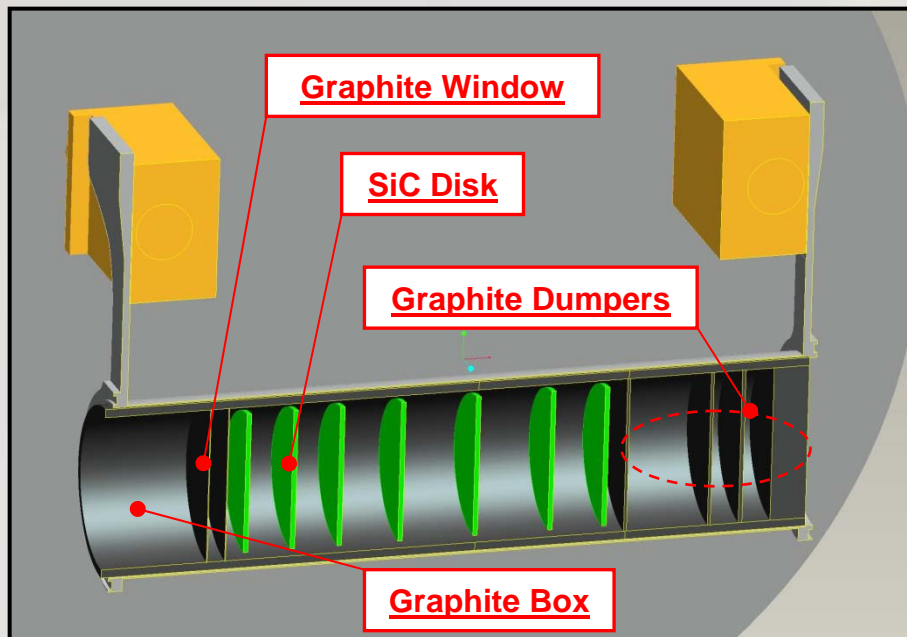

# The SPES target prototype

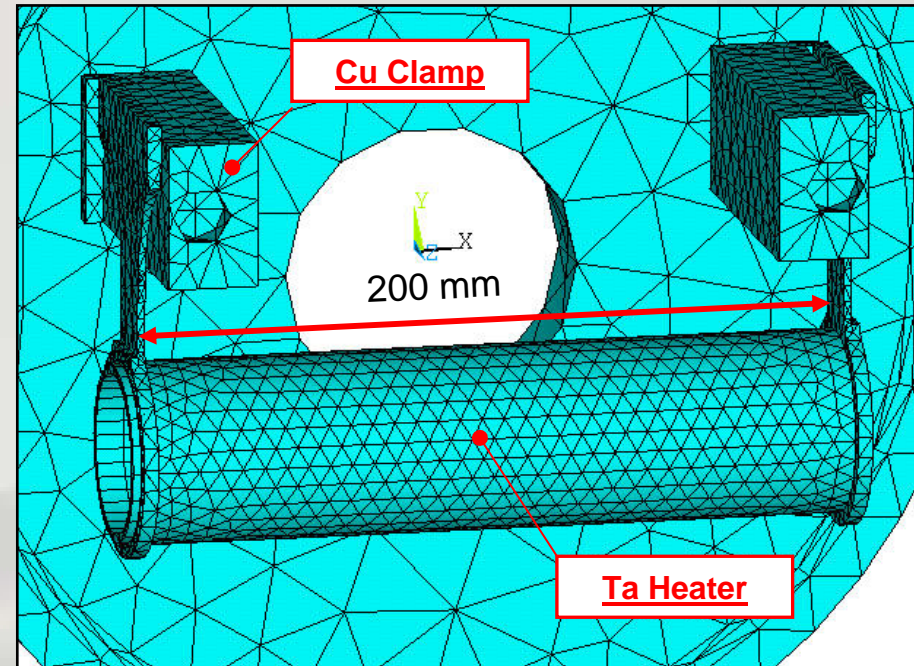
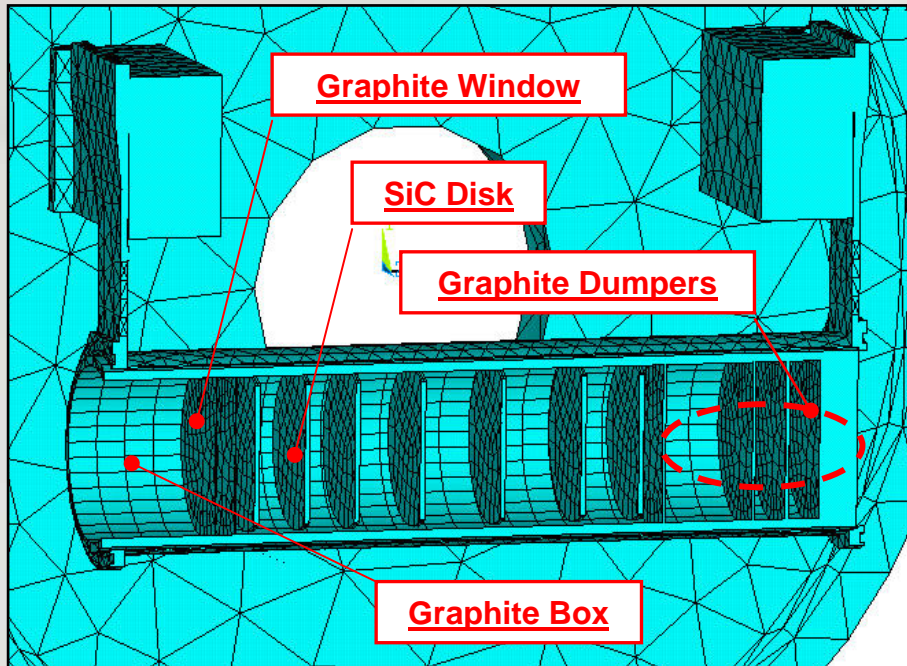

## THERMAL-ELECTRIC COUPLED FIELD FE ANALYSES

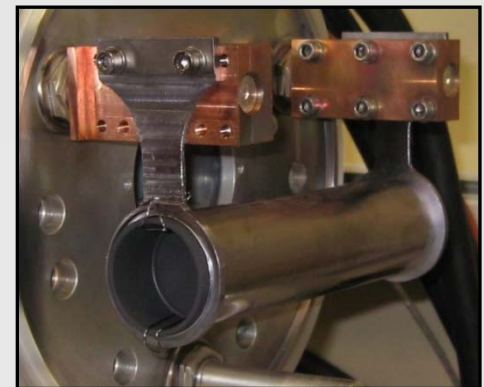

# The SPES target prototype

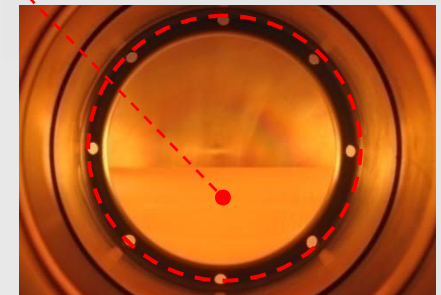
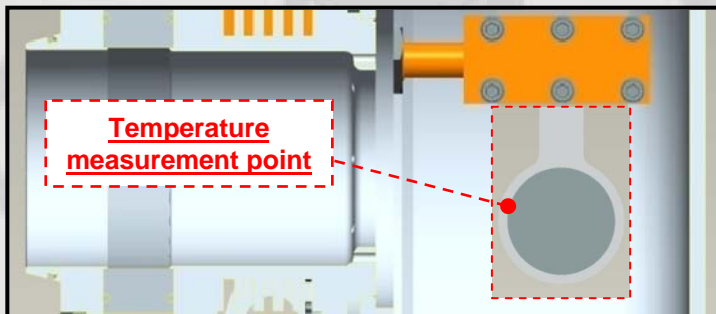
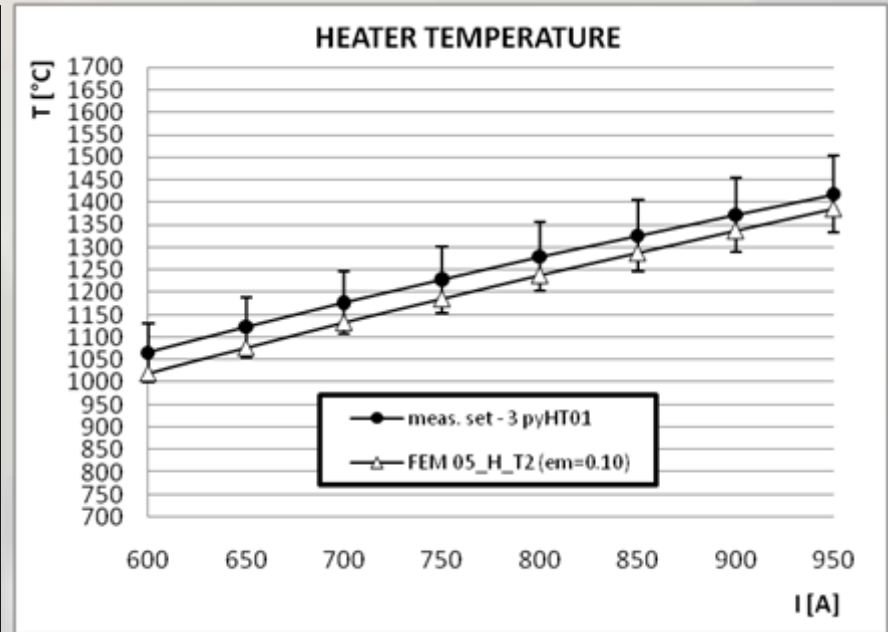
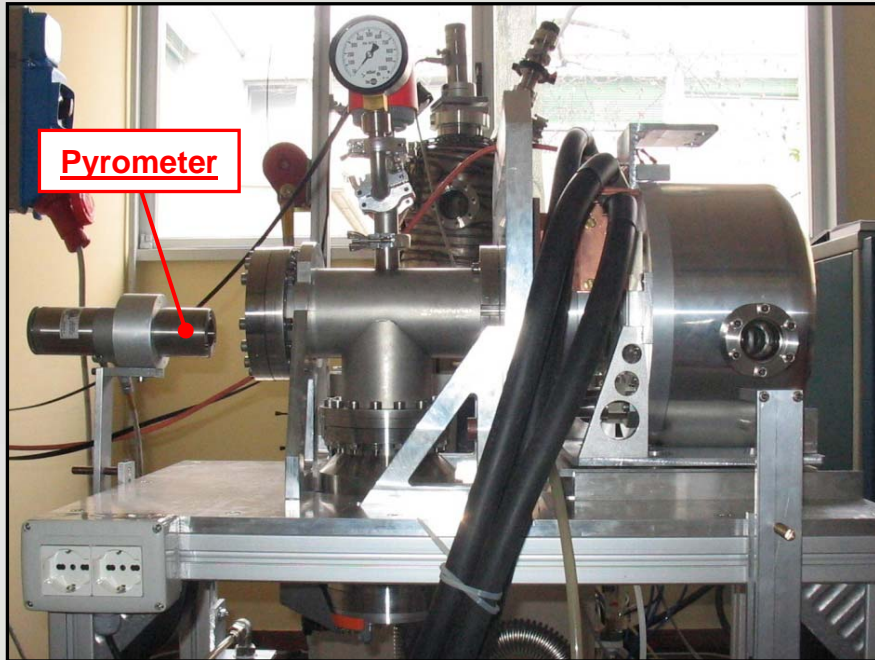



# The SPES target prototype

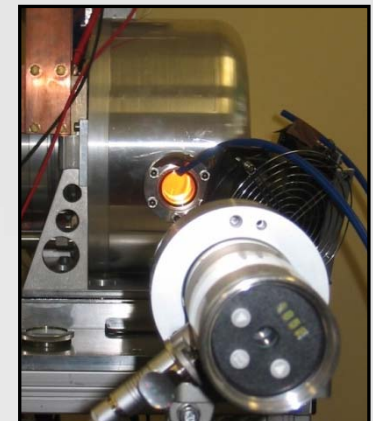
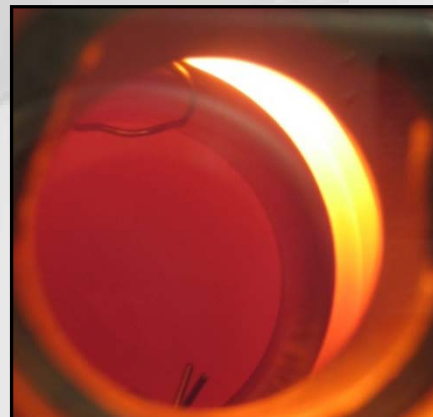
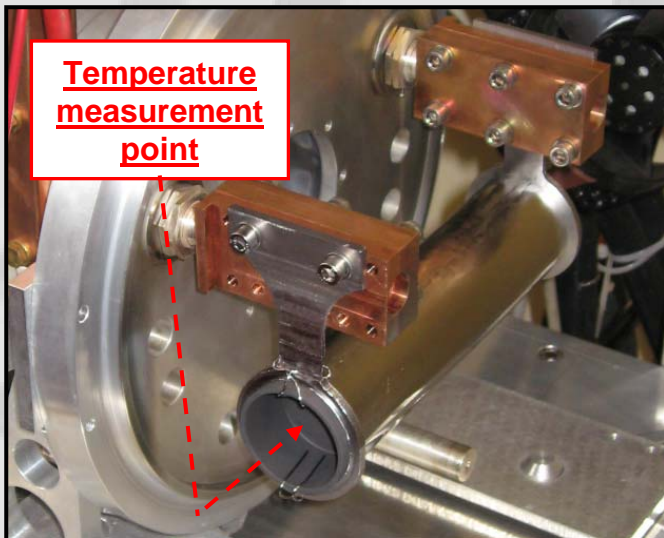
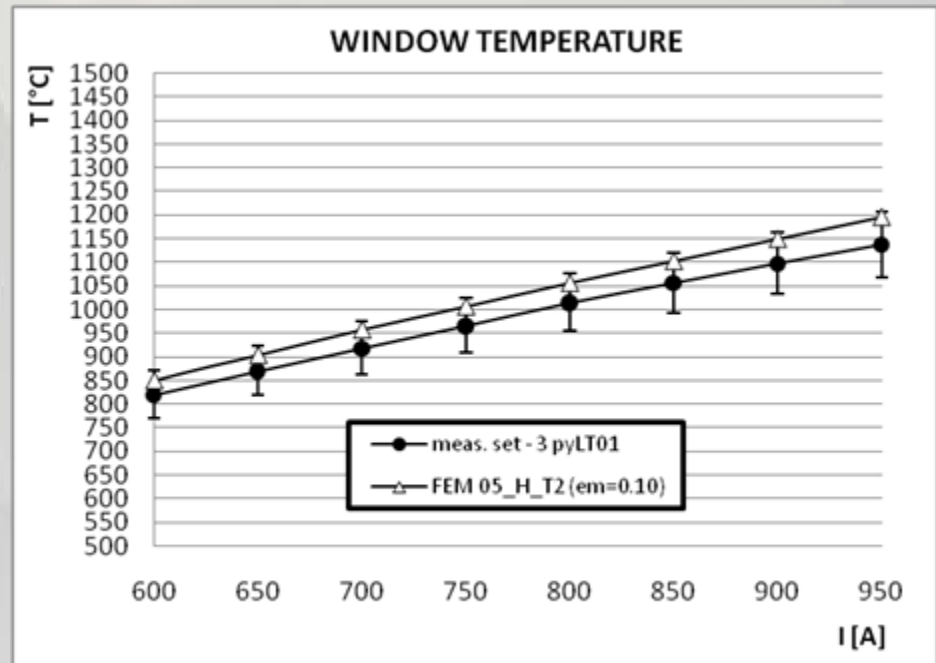
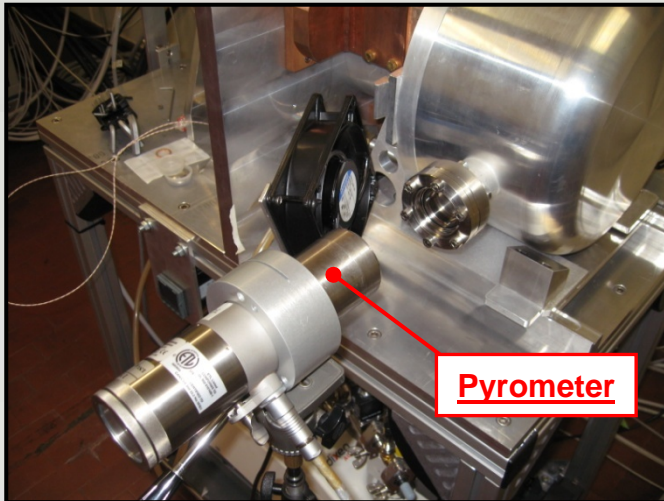

# The SPES vacuum chamber

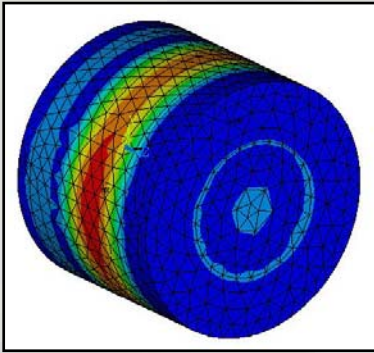
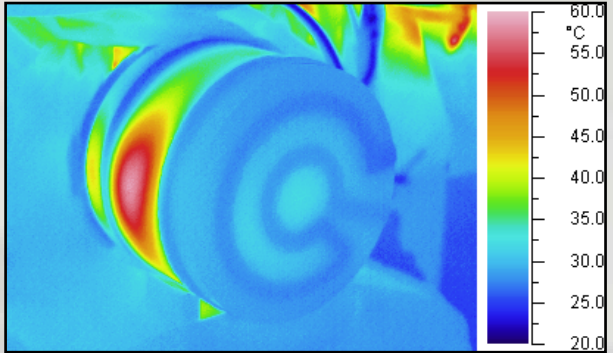
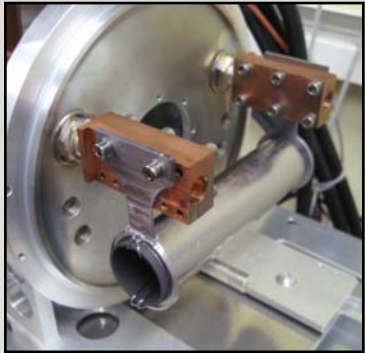

## UPGRADING OF THE "ISOLDE (CERN)" VACUUM CHAMBER

---

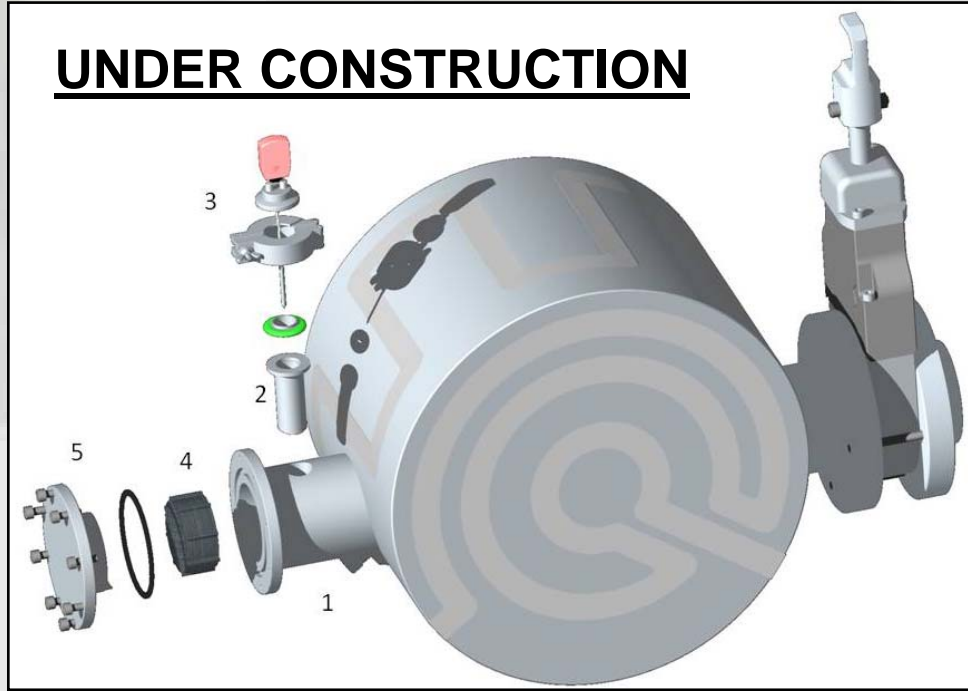
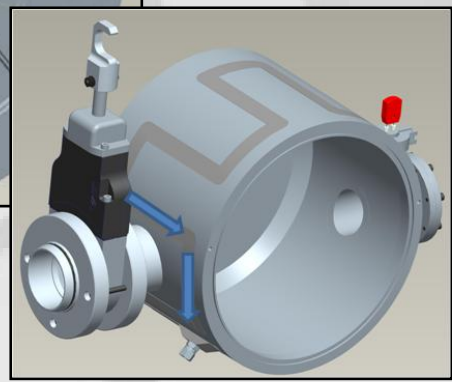
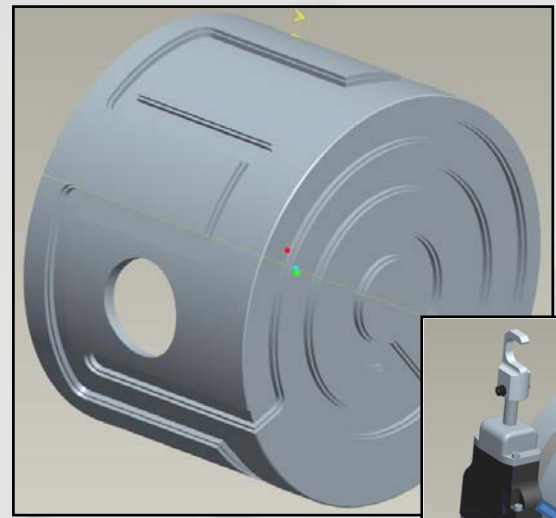

## SPES carburization furnace

(from Uranium Oxide to Uranium Carbide)

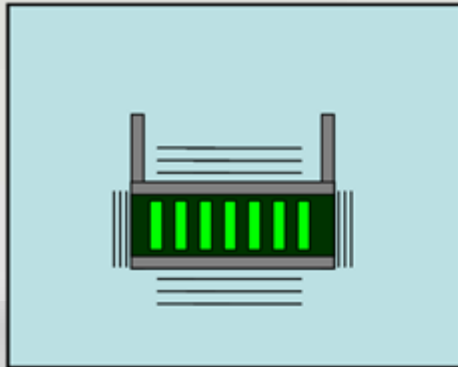

## SPES chamber

(Facility working condition with Proton Beam)

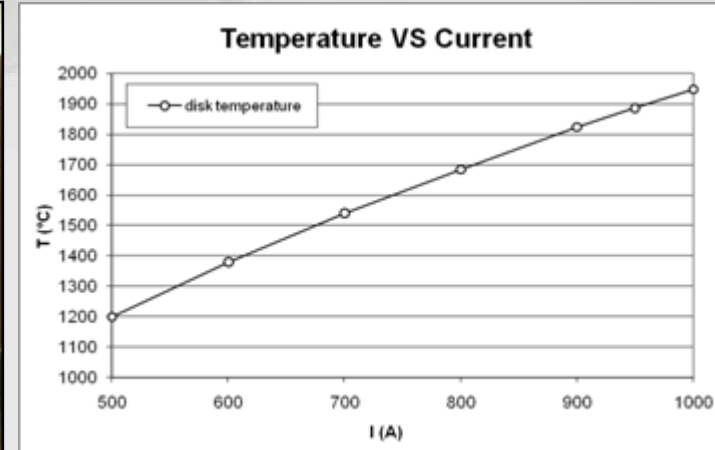
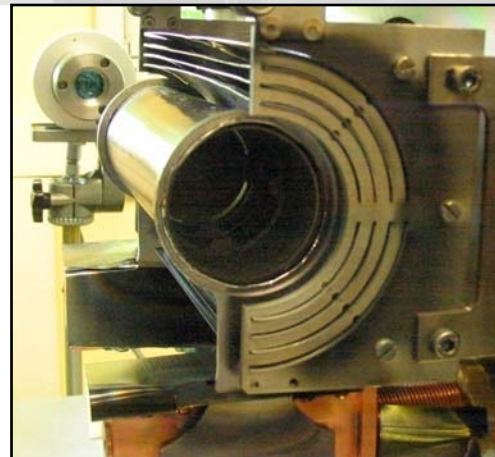
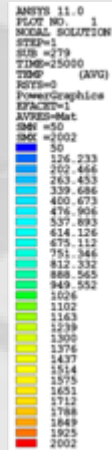
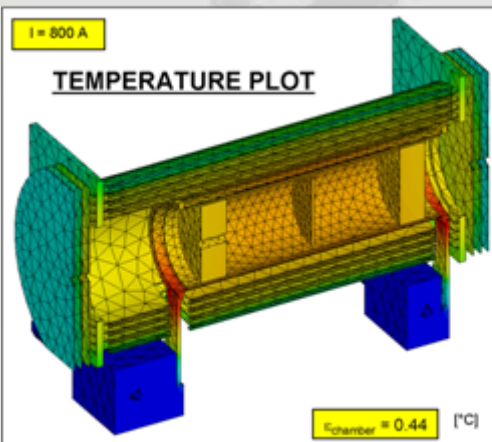
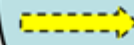
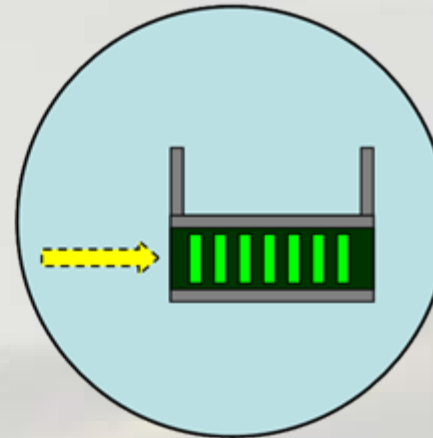

# WG2

# Material Developments

# Production of $UC_x$ 13 mm pellets

## PRODUCTION OF OXIDE PELLET

Mixing & Cold Pressing

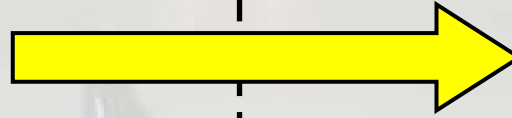

## THERMAL TREATMENT

Up to 2000°C (several days)

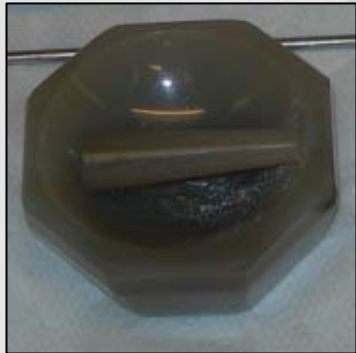

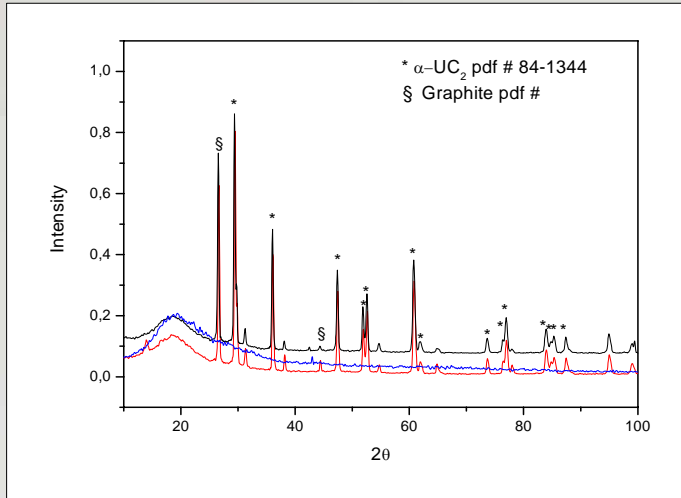

**SEM = Scanning Electron Microscope**

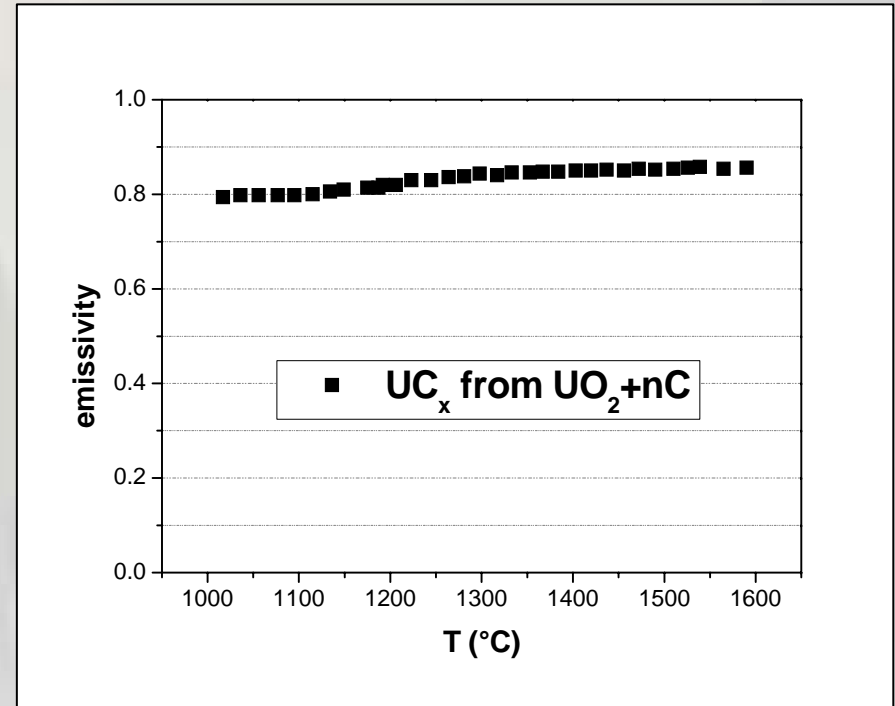

**Emissivity measurements by dual frequency pyrometer**

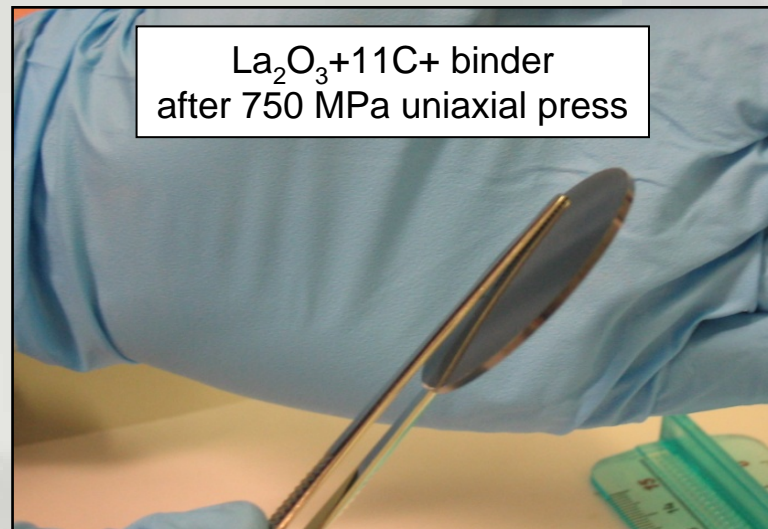

## Vertical Sintering of 40 mm $\text{LaC}_2$ disks inside the SPES graphite target box

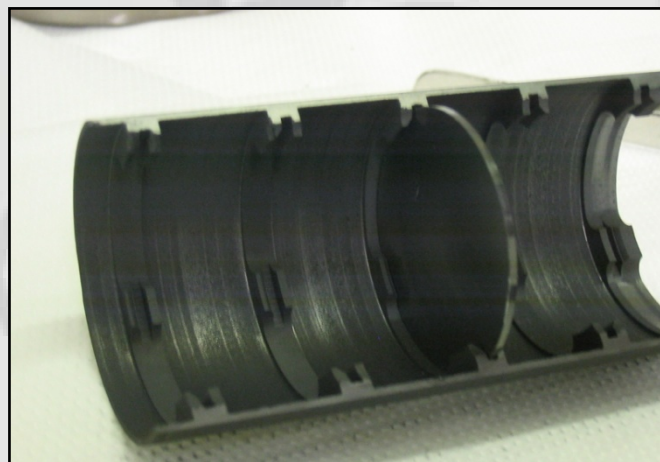

Sintering process  
with the disk in  
vertical position



Process  
completed  
successfully

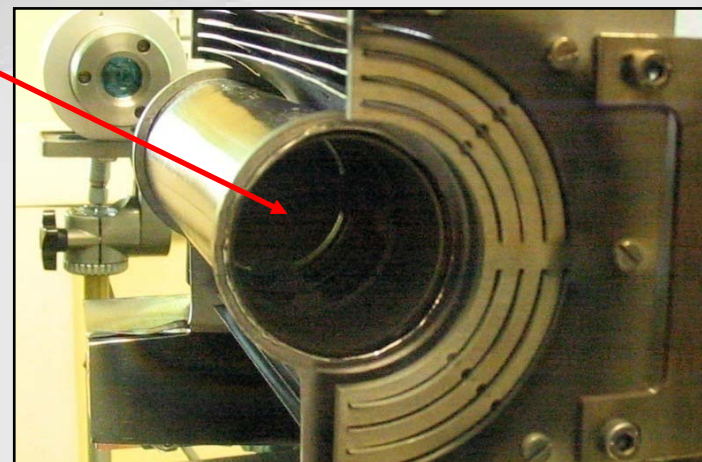

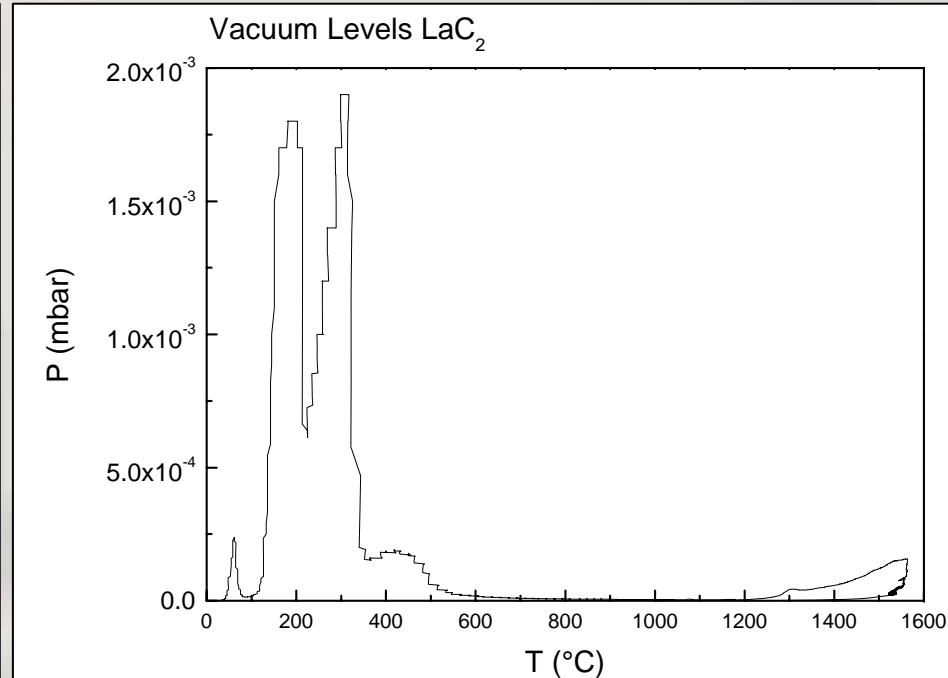
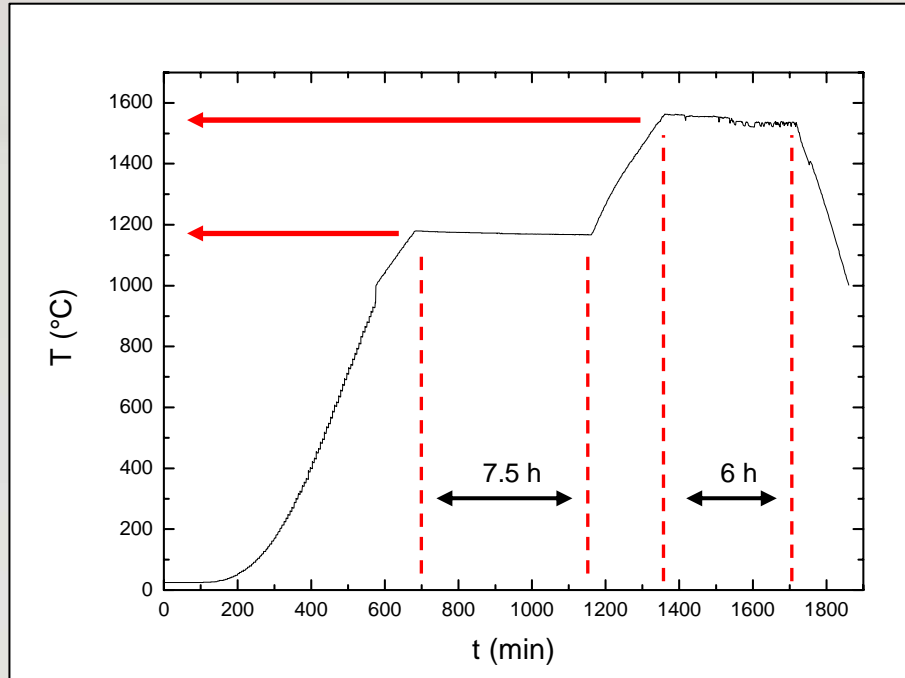

## Carburization and sintering of $\text{LaC}_2$ disks



# WG3

# Ion Source Developments

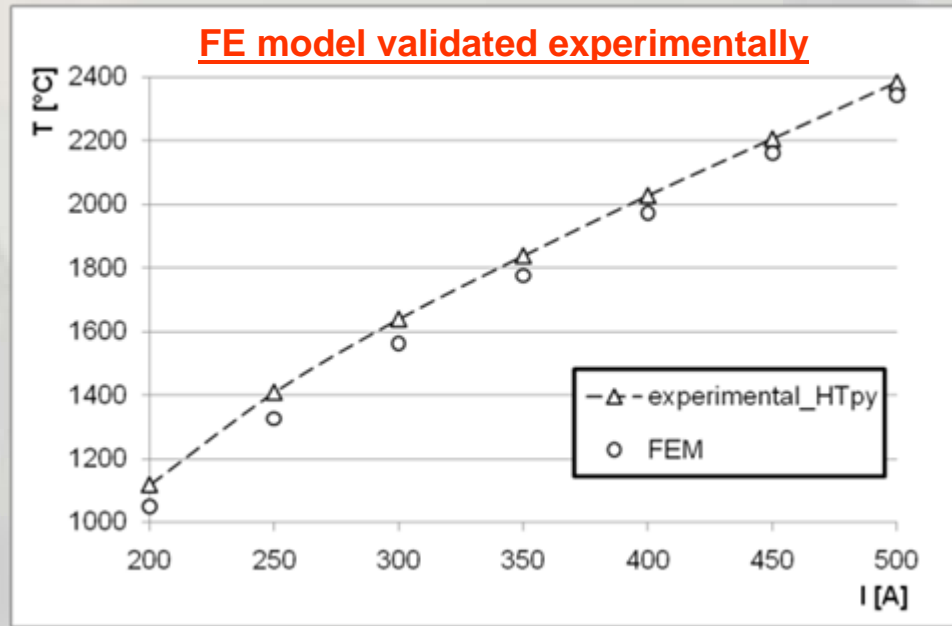
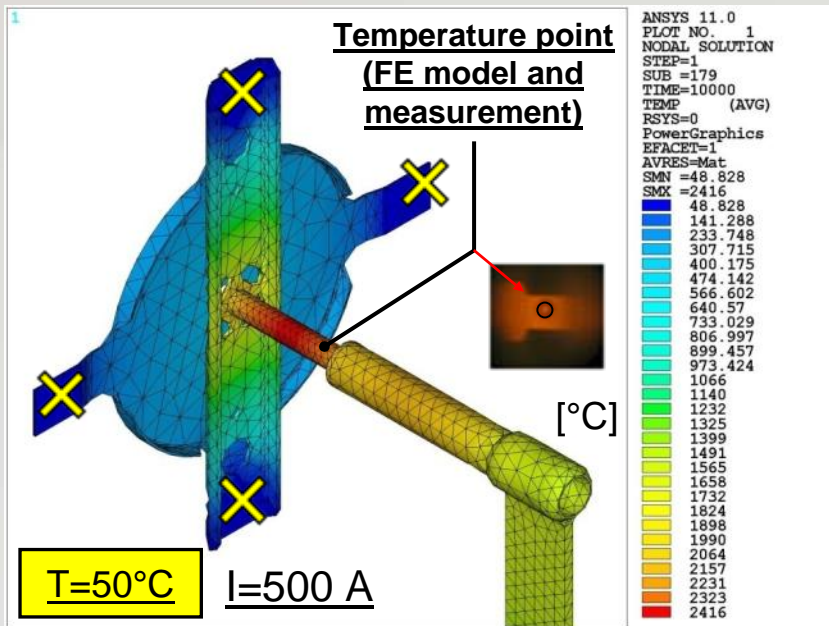

## EXPERIMENTAL APPARATUS

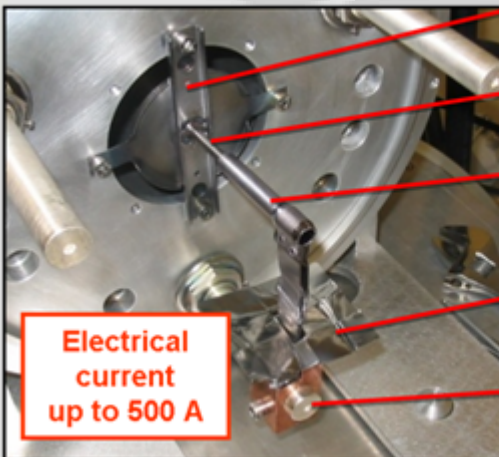

- **Tube Support**  
(Material: Tantalum)
- **Hot Cavity**  
(Material: Tungsten)
- **Connection element**  
(Material: Tantalum)
- **Tantalum sheet**  
To reduce copper sublimation
- **Clamp**  
(Material: Copper)

**Electrical current up to 500 A**



# Ion Source: laser photo-ionization

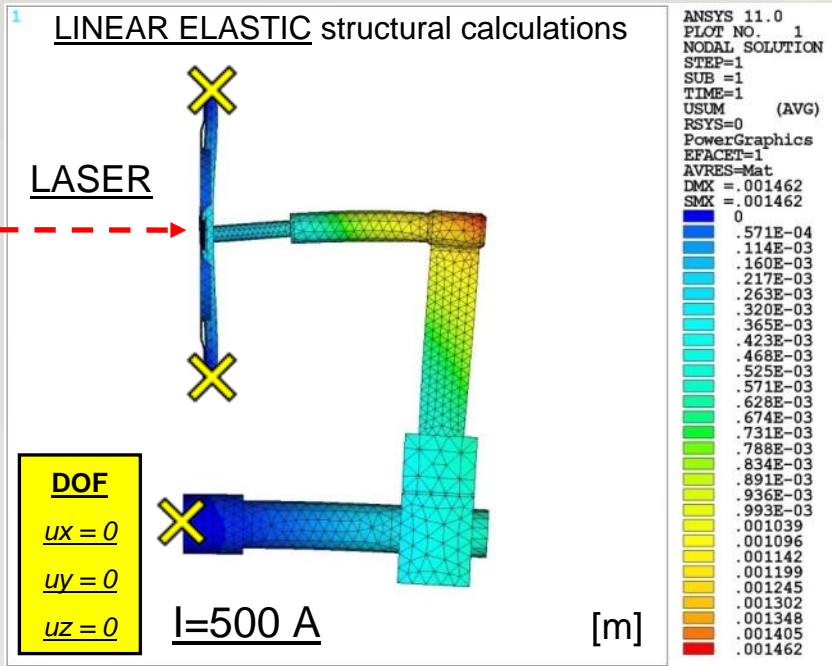

LASER photo ionization: activity started at Pavia (University and INFN section)

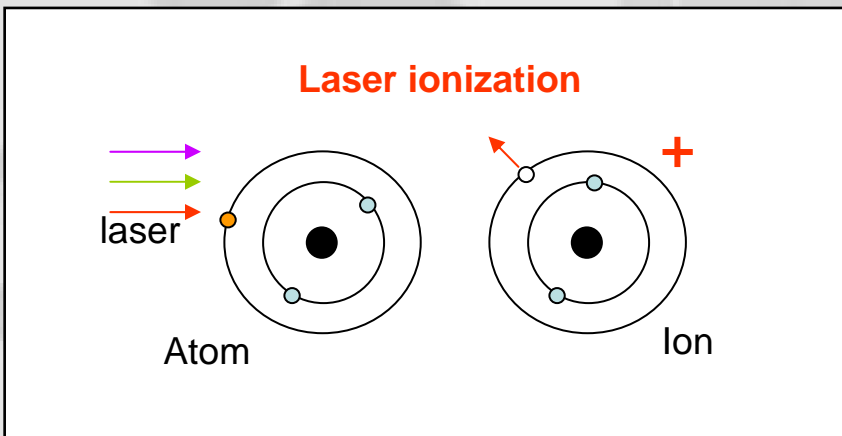

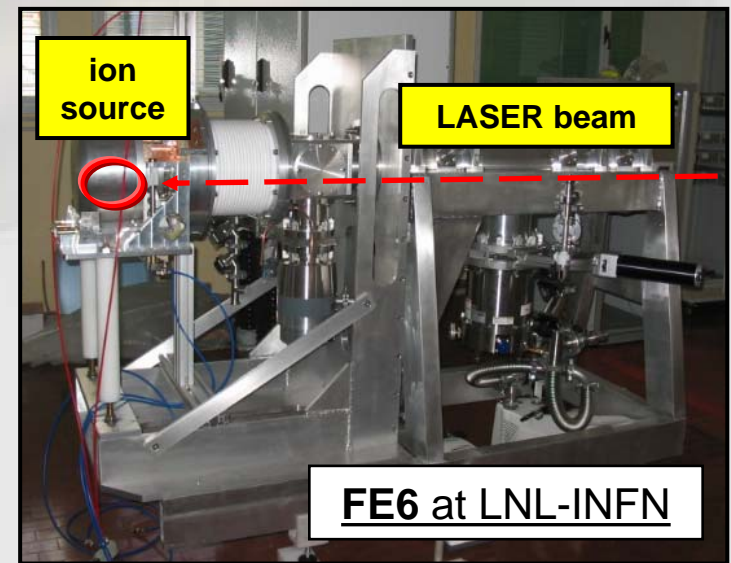
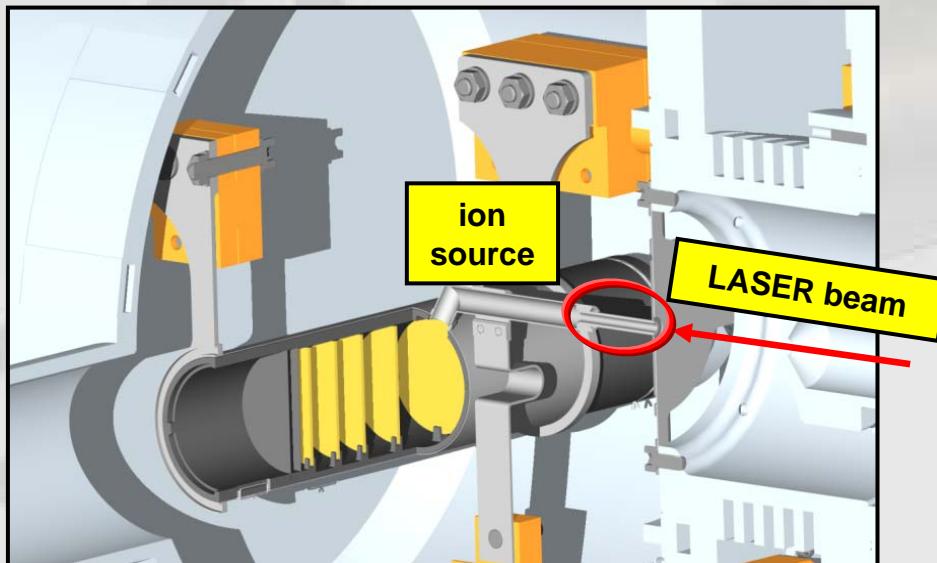
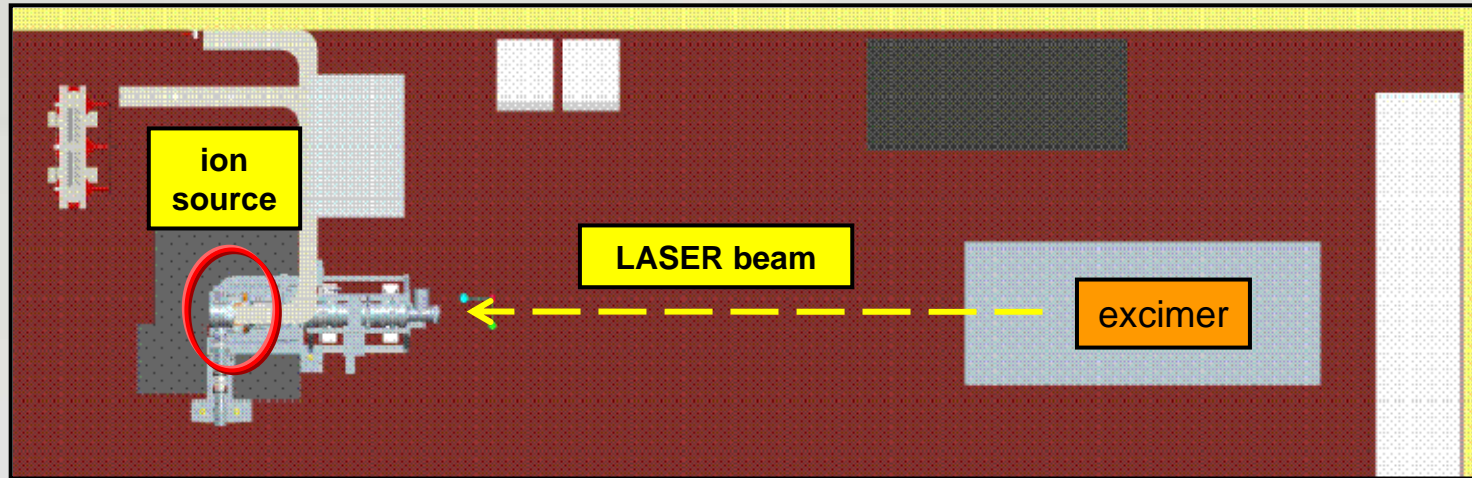

# WG4 Target Handling

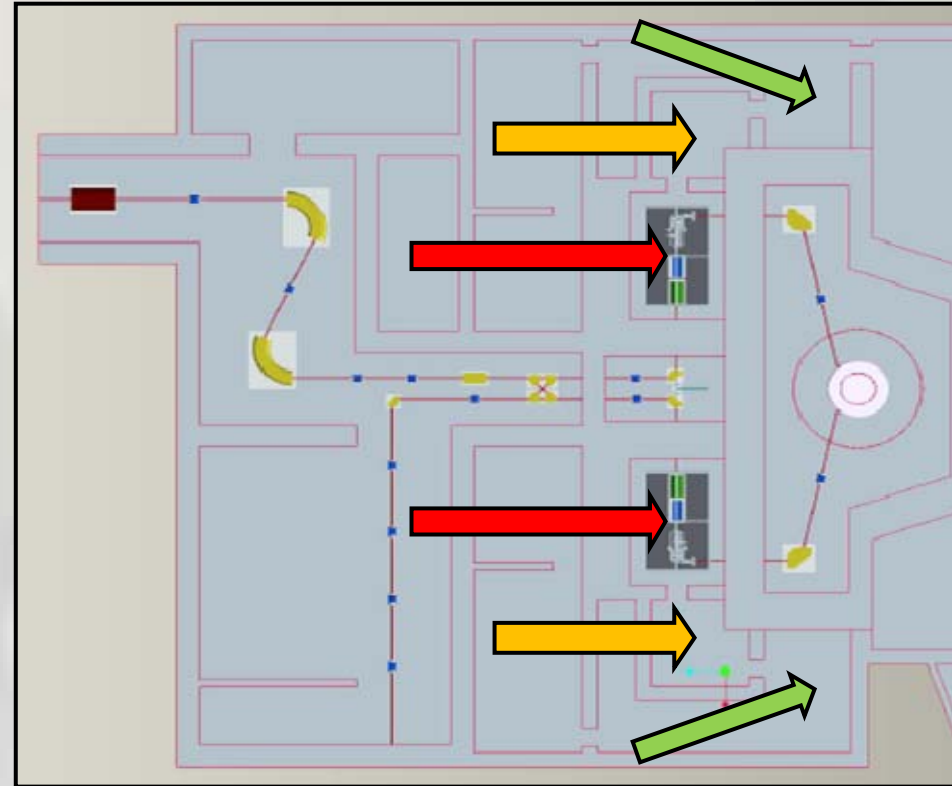
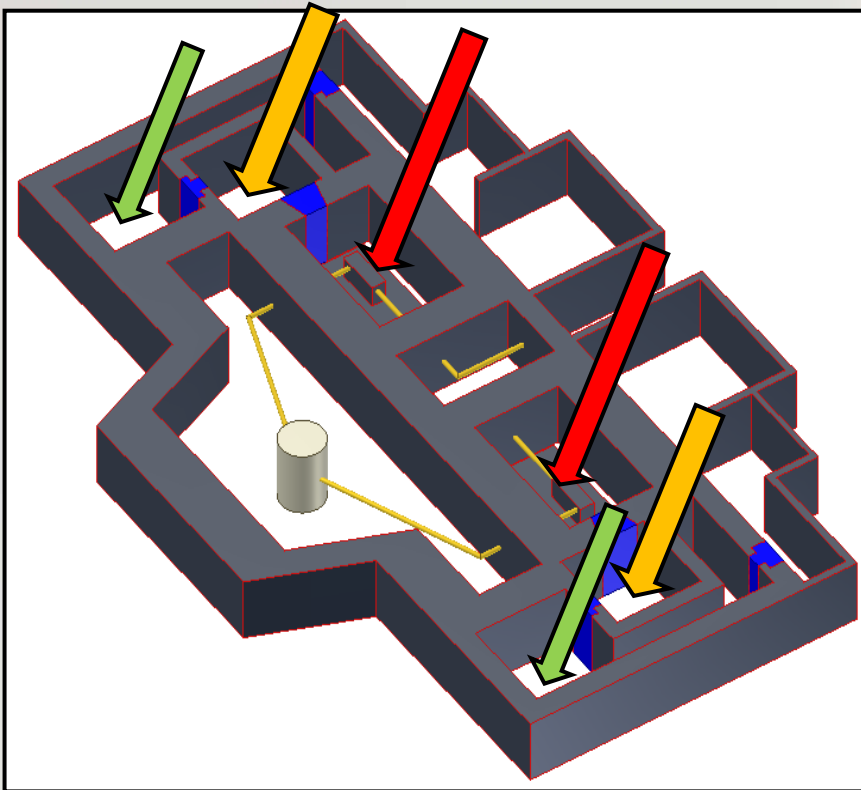

Front end area



Handling zone



Services zone

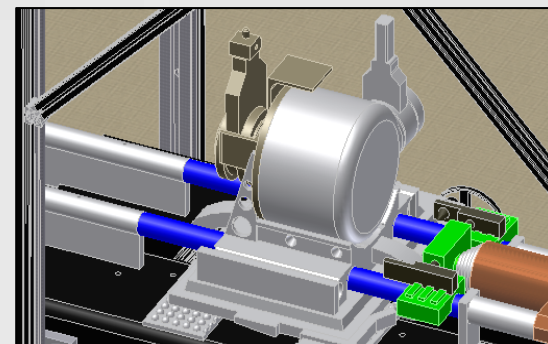

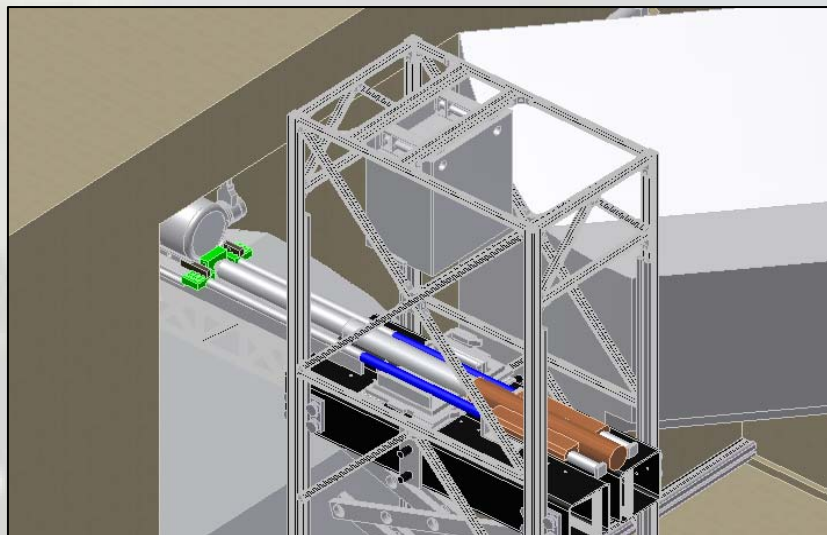
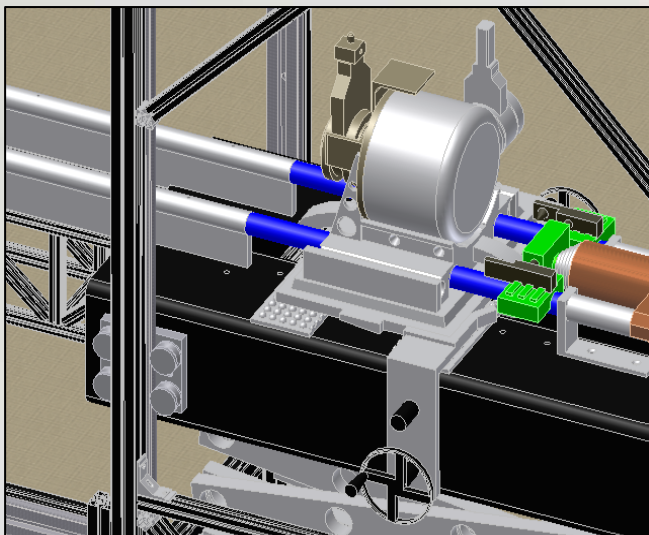

Thanks to Trento University SPES group

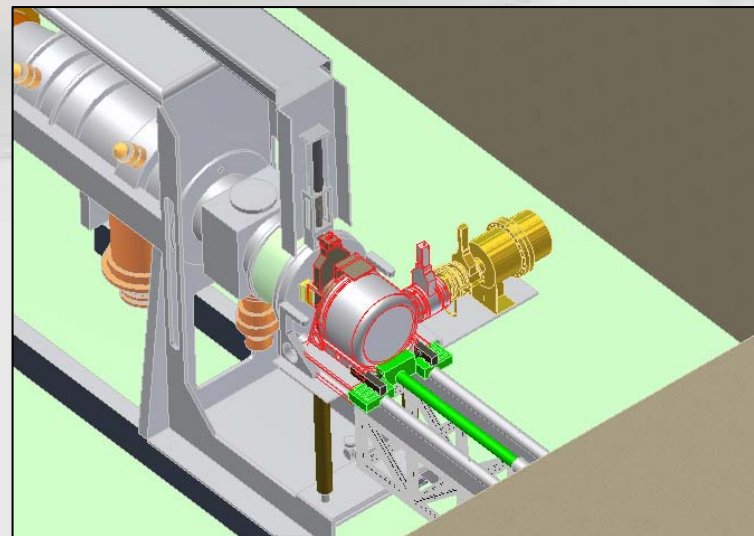
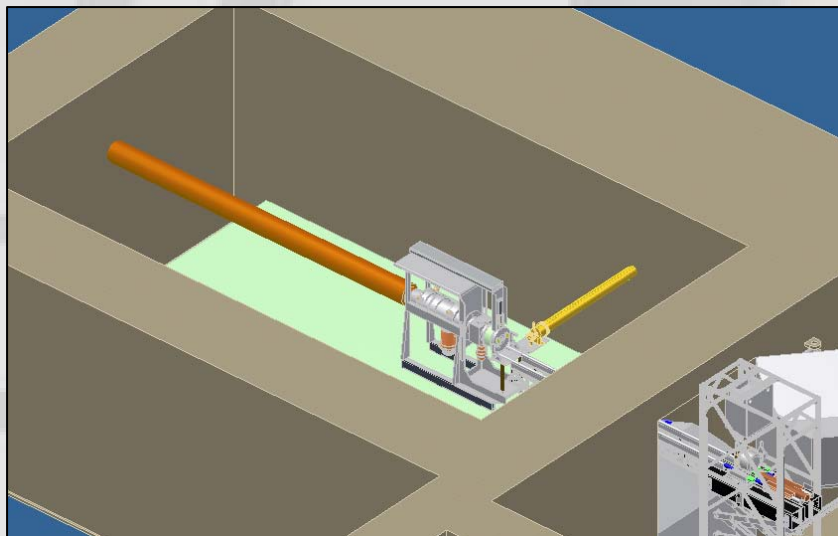

# Status of the SPES Laboratories



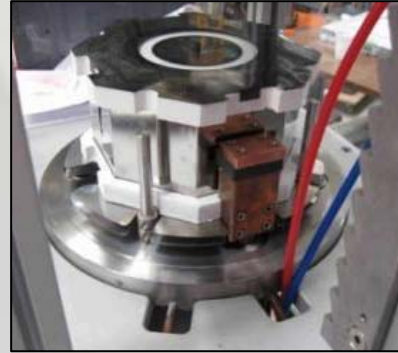
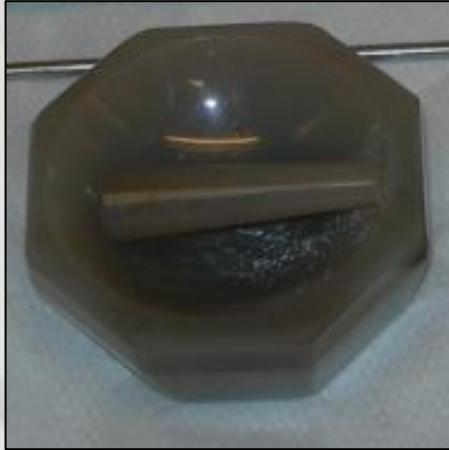
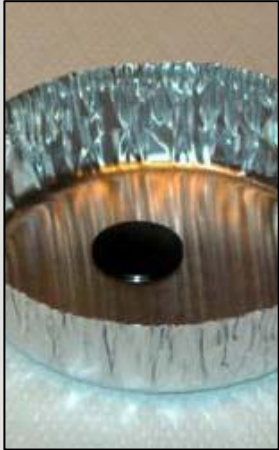



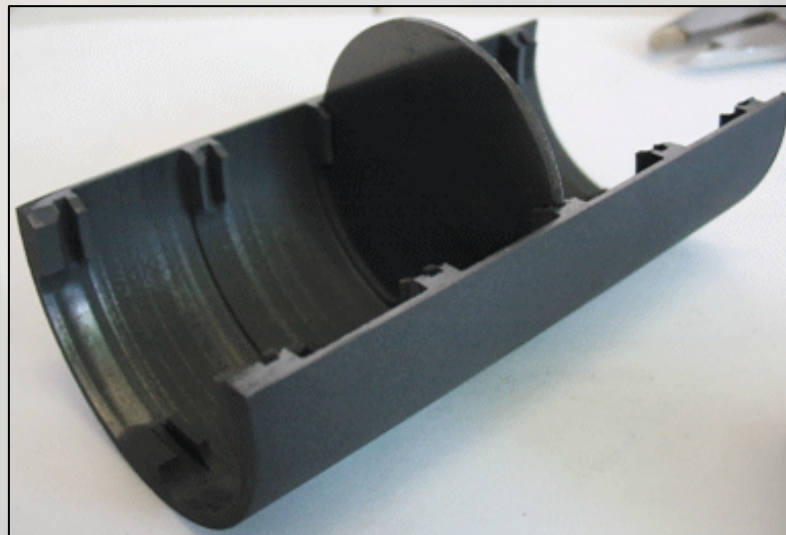



Front End built in collaboration with the INFN sections of Milano and Pavia

Original project developed by Stefano Marzari (CERN - Switzerland)

# THANKS A LOT FOR YOUR ATTENTION!

## SPECIAL THANKS TO:

- Michele Lollo
- Luciano Costa
- Mauro Giacchini