

## STATUS OF PUMP-PROBE LASER DEVELOPMENT FOR THE EUROPEAN XFEL

L. Wißmann<sup>#</sup>, M. Emons, M. Kellert, K. Kruse, G. Palmer, M. Pergament, G. Priebe, J. Wang, U. Wegner, and M. J. Lederer, European XFEL GmbH, Notkestrasse 85, 22607 Hamburg, Germany

### Abstract

The European XFEL is under construction and is designed to become a multi-user facility. Three SASE beam lines with two experimental areas each are foreseen to guarantee a high user throughput. In order to enable the full scientific potential of the facility, optical laser pulses for either pumping or probing samples will be deployed regularly.

We are presenting the pump-probe laser concept and the current status of the development, showing some experimental results of the prototype laser, achieved to date. The main emphasis of the presentation lies on the integration of the laser system into Karabo, the emerging control system of the European XFEL.

### INTRODUCTION

The requirements for the pump-probe laser system (In the following: ‘PP laser’) are given by the XFEL accelerator (burst repetition rate 10 Hz, intra-burst pulse repetition rate 4.5 MHz, burst length 600  $\mu$ s, high arrival time stability) and the needs of experimentalists (pulse energy, pulse length, arbitrary pulse picking, wavelength tunability). Machine operation demands a high uptime while long-time planning and different experimentalists’ needs require high flexibility of the design. The general concept relies on a burst-mode, ps-pumped non-collinear optical parametric amplifier (NOPA), which draws on commercially available components where possible, and utilizes collaborative or in-house developments where needed.

The most important subsystems of the PP laser are described first, as depicted in Fig. 1. In the second half of this paper the integration of the laser into the control system is outlined, covering the necessary hardware, software, and machine timing issues.

### PP LASER SUBSYSTEMS

A stable seed oscillator (OneFive Origami10), which is locked to the XFEL laser master oscillator via the optical synchronization system, emits a 54 MHz pulse train at 1030 nm. The timing jitter of the oscillator itself is specified to be <20 fs (rms, [1kHz-10MHz]). The endpoint-to-endpoint stability of the synchronization systems is envisioned to reach 20 fs after XFEL commissioning [1]. Passive and active measures are taken to maintain this arrival time stability unto the exit of the PP laser.

For laser/x-ray overlap search, a long delay stage is implemented (Feinmess PMT 240). It supports a travel range of 400 mm (5 ns, quadruple pass) with an encoder resolution of 100 nm (stable 200 nm or 2.5 fs steps shown). Coupling the laser pulses into a single mode fiber for front end seeding has been successfully tested and yields less than 3% deviation over the full travel range.

The All-Fibre Front-End has multiple tasks [2]. It consists of several fibre amplifier stages, pulse picking devices, chirped fiber bragg gratings for dispersion management and extensive timing and control electronics. The laser pulse train from the seeder is split after pre-amplification and pre-stretching into two paths, XF1 (for power amplification and NOPA pumping) and XF2 (for supercontinuum generation and NOPA seeding). The output of the XF2 path is a 5 ms long burst with 4.5 MHz intra-burst repetition rate and a burst power of 20 W. An acousto-optic modulator (AOM) enables the selection of arbitrary pulse patterns inside the burst, before the pulses are compressed to 300 fs for supercontinuum generation.

In the XF1 path, the front-end output pulse train can be chosen to have different intra-burst repetition rates at constant burst power (of 4 W). This constant power mode enables different working points of the whole PP laser (incl. burst mode pump-pulse amplifiers). The tested repetition rates are 4.5 MHz, 1 MHz, and 0.2 MHz. The output burst length is again 5 ms, the pulse duration being 1.3 ns, and the spectral properties are optimized for the subsequent power amplifiers.

Further down the XF1 path, an InnoSlab multi-pass amplifier enhances the burst power to 400 W [3]. Two double-pass booster stages are planned to sequentially reach power levels of 7 kW and 20 kW. The currently achieved performance includes burst powers of 600 W (400 W specified), and with settable intra-burst frequencies of 0.2 MHz to 4.5 MHz this corresponds to 0.09 mJ to 2.1 mJ at 400W. The spectral width of the output pulses is measured to be  $\Delta\lambda = 2.5$  nm, the beam quality factor  $M^2$  equals 1.5, and the constancy of the pulse energy over the burst (in a 600  $\mu$ s window) is better than 1%. Intra-burst variations of beam shape and pointing have been measured to be negligible.

A Pockels cell arrangement, suited for high laser energies, is used to enable arbitrary pulse picking also in the pump path. Alternative, user selectable, beam exits before the XF1 compressor (pulse length ~ns) and after the XF1

<sup>#</sup>laurens.wissmann@xfel.eu

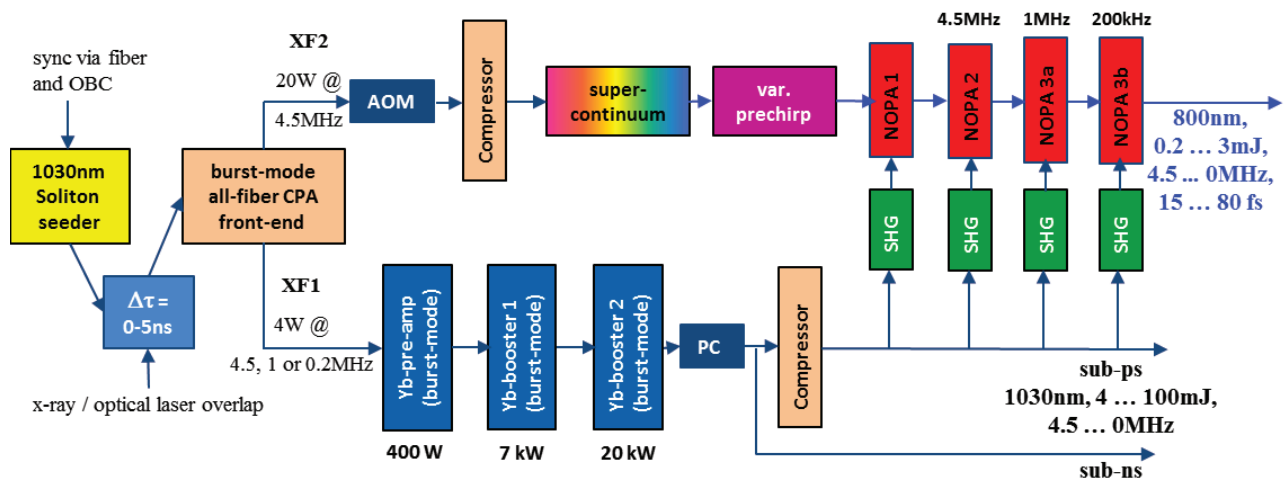

Figure 1: The planned PP laser system. The prototype is equipped with only 2 NOPA stages and one 400 W amp.

compressor (pulse length  $\sim 800$  fs) are foreseen to enable the use of the 1030 nm, high power beam as alternative to the 800 nm short pulse output from the NOPA. To pump the NOPA with 515 nm light, frequency doubling is installed with an efficiency of  $\sim 65\%$ .

In the XF2 path, following supercontinuum generation in YAG, the pulses have a spectral content ranging from 600 nm to 1000 nm, and an energy of 7.2 nJ under stable conditions. Pairs of compensated chirped mirrors imprint a negative chirp on the pulses to enable fused silica for compression after parametric amplification. With different setups of the chirped mirrors and usage of the two available NOPA stages, a range of output pulse parameters is accessible. The shortest pulses, compressible to 14.9 fs, have a spectral bandwidth of 155 nm at 10% of maximum and are centered at 810 nm. At 200 kHz, a pulse energy of 180  $\mu$ J was achieved, corresponding to 34 W burst power. In the long pulse mode (up to 75 fs), only a fraction of the white light is selected through dispersive amplification filtering, allowing a wavelength tuning over 100 nm by shifting the seed temporally against the pump pulse. A detailed overview is given in [4].

For power scaling to a pump pulse energy level of 100 mJ, the envisioned booster amplifiers have already been installed and are being commissioned at this time. With the first booster, beam characterization at a power level of up to 4.5 kW is taking place. In order to exploit the pump power of the booster amplifiers, further NOPA stages need to be set up.

### ACTIVE AND PASSIVE STABILITY

Environmental influences will impact on the pulse arrival time stability of the seed and pump pulses in the NOPA stages. This temporal stability is crucial as otherwise the NOPA output becomes unstable. Typical causes for drifts are temperature and humidity changes. Passive means to ensure stability include choice of materials and the use of sound principles. Nonetheless, due to the long optical paths, drifts of  $>100$  fs are to be expected, which call for active means of stabilisation. For instance, highly

stable air conditioning ( $\pm 0.1^\circ\text{C}$ ,  $\pm 2.5\%$  rel. hum.) for the laser table area and active timing drift compensation are implemented. The latter consists of two optical balanced cross correlators, which measure the arrival time drift between the seeder and XF2 as well as XF2 and XF1, respectively at the input of the NOPA. A clocked and triggered readout of the arrival time change of single pulses in the burst is fed to a control loop which acts on piezo delay stages (see below).

Furthermore, active beam pointing stabilisation (TEM) has been implemented yielding pointing deviations as low as  $1/40$  of the beam divergence.

### PP LASER INTEGRATION

The PP laser is not a stand-alone R&D laser system. Three copies of it shall be installed in three laser hutches to serve six experimental areas as laser source. Experimentalists will have the control over crucial parameters of the laser system remotely (output power, pulse pattern, pulse arrival time). To this end and to receive status info of this XFEL subsystem, full integration of the PP laser into the emerging XFEL control system Karabo is desired. The installation of a diagnostic & control rack has been completed to host the required hardware (see Fig. 2). Its contents are, from top to bottom:

- A Beckhoff programmable logic controller (PLC) controls motors of differing kind and also features analogue and digital in- and outputs. This hardware is used for slow data exchange, as it is neither clocked nor triggered.
- A piezo driver to amplify the signals from the analogue PLC outputs before they are fed to piezo actuators (pulse arrival time stabilisation and oscillator locking to an RF reference).
- The driver for the seeder oscillator.
- The controller for the beam pointing stabilisation.
- Two delay generators to multiply triggers.
- A large rack mounted PC serving control purposes.
- A multi-purpose laboratory DC power supply.

- For fast data taking and computing, a  $\mu$ TCA.4 crate has been set up, equipped with a card for timing purposes and a fast ADC (Struck SIS8300, 125 MS/s, 10 channels), beside the standard components (power supply, CPU, MCH). The  $\mu$ TCA.4 standard has been developed to support extended backplane features (clock and trigger support) and flexible designs for rear transition modules (RTMs), of which full use is made.
- A HV driver for the Pockels cell, some RF circuitry and network switches.

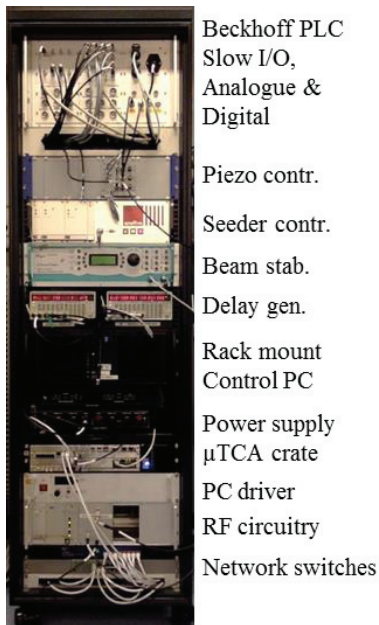

Figure 2: Fully equipped control and diagnostics rack.

## KARABO

Karabo, the emerging control system of the photonic part of the XFEL, is a modular software framework designed for control, data acquisition, data management, and scientific computing [5]. The PP laser integration is quite advanced and serves as a test bed for the software stability and performance. Karabo devices as plug-in modules form the interface to any hardware or software. Many devices exist already, tested or regularly used are

- The remote client for front-end control
- An imaging tool for small CCD cameras (Basler), with a computing tool extracting beam positions
- A spectrometer and an energymeter tool
- Motor devices for small linear and rotary stages
- A motor control device for the long delay stage
- Analogue and digital I&O devices, among these also temperature sensors
- A sophisticated ADC firmware interface to allow for data reduction in the arrival time stabilisation
- A generic PID device to create control loops.

On the way are more software devices, allowing

- Remote control of the beam stabilisation (TEM)
- Interfacing the InnoSlab amplifiers
- Computing pulse lengths from single-shot autocorrelator images
- Use of a large CCD camera (36 x 24 mm sensor).

For Karabo, a graphical and a command line interface exist, the latter featuring full iPython compatibility. The GUI allows for distributed and remote access, use of individualised panels, access to history data, and project definition (easy device handling, process control).

## TIMING

The PP laser has to be fully synchronised to the XFEL. A sophisticated  $\mu$ TCA.4 based machine timing system has evolved from the system used at FLASH [6]. It relies on length stabilised optical fibre links between timer cards (x2 timer) to synchronise the distributed 1.3 GHz clocks. Before every burst the clocks in every timer board are reset. With this resync pulse, information on the burst filling at each PP laser position is spread, as well as the request for a PP laser pulse for each possible position in the burst. Each timer card has 6 front trigger outputs with settable delay, width, and internal trigger source. Also each card features an extension slot (RTM) with 6 more independent trigger outputs. Beside the network based modes, a timer card can also be operated stand-alone. Currently, the reference clock of the prototype system is derived from the seed laser oscillator. All triggers (amplifiers, diagnostics, ADCs) are then created inside the timer card. Varying pulse patterns have been realised remotely using the full capabilities of the timer card.

## CONCLUSION

A fully operational prototype system of the envisioned PP laser has been set up. Extensive measurements of the system performance have shown all desired parameters can be reached. An upgrade to scale power to the final specifications is under way.

The hardware assembly needed for the integration of the PP laser into the emerging control system is completed. Corresponding software devices are largely available.

## REFERENCES

- [1] C. Sydlo et al., “Development Status of Optical Synchronization for the European XFEL”, IBIC 2013, Oxford, MOPC32, <http://www.JACoW.org>
- [2] K. Kruse, et al., “All-fiber 1030nm burst-mode front-end amplifier for the European XFEL pump-probe laser development for the European X-Ray Free-Electron Laser Facility,” Paper Mo4.5, Ultrafast Optics Conference IX, 04–08 March 2013, Davos
- [3] M. Kellert et al., “High power femtosecond 1030nm burst-mode front-end and pre-amplifier for the European XFEL pump-probe laser development,” Poster CA-P.23, CLEO 2013, 12–16 May 2013, Munich

- [4] M. Pergament et al., “High power burst-mode optical parametric amplifier with arbitrary pulse selection”, ttp 2014, submitted to Optics Express.
- [5] B.C. Heisen et al., “Karabo: an integrated software framework combining control, data management and scientific computing tasks”, 14th Intern. Conf. on Accelerator & Large Experimental Physics Control Systems, ICALEPCS 2013, San Francisco, U.S.A.
- [6] K. Rehlich et al., “The New Timing System for the European XFEL”, 14th Intern. Conf. on Accelerator & Large Experimental Physics Control Systems, ICALEPCS 2013, San Francisco, U.S.A.