

# HIGH-GRADIENT CATHODE TESTING FOR MaRIE<sup>\*,†</sup>

J.W. Lewellen<sup>#</sup>, N.A. Moody and F.L. Krawczyk, AOT-AE, LANL, Los Alamos, NM 87544 USA

## Abstract

X-ray free-electron lasers (X-FELs) provide unprecedented capabilities for characterizing and controlling matter at temporal, spatial and energetic regimes which have been previously inaccessible. The quality of the electron beam is critical to X-FEL performance; a degradation of beam quality by a factor of two, for instance, can prevent the X-FEL from lasing at all, rather than yielding a simple reduction in output power.

The beam source for the world's first X-FEL, the LCLS at SLAC [1], defines the current state-of-the-art. Next-generation X-FELs such as MaRIE [2], intended to lase at 40 kV and beyond, will demand much higher quality electron beams, delivered at higher repetition rates, than present-generation injectors can deliver.

While conceptual designs for new beam sources exist [3], they incorporate assumptions about the behavior of the photocathode under extreme operating conditions. The combined requirements for high bunch charge, short bunch duration, and small emission area, dictate the use of high-efficiency photocathodes operating at electric field gradients of  $\sim 140$  MV/m and durations of  $> 10$   $\mu$ s. No suitable cathode has been operated under these conditions, however, so the success of next-generation X-FELs rests on a series of untested assumptions. We present our plans to address these knowledge gaps, including the design of a high-gradient RF cavity specifically designed for testing cathodes under MaRIE-relevant conditions.

## INTRODUCTION

The MaRIE X-ray free-electron laser is intended to produce coherent X-ray photons at energies of 40 kV and higher. MaRIE requires a 12-GeV electron beam at the undulator with a normalized emittance of  $\sim 0.1$   $\mu$ m RMS, a duration of 12 fs, an energy spread of  $< 0.015\%$ , and a bunch charge of 100 pC. Further, the MaRIE linac must deliver a pulse train to the undulator, with RF macropulse-average currents up to  $\sim 100$  mA. These requirements, in turn, place extreme demands upon the MaRIE beam source and, in particular, the cathode.

### Cathode-Related Considerations

The beam emission radius on the cathode must be small, on the order of a fraction of a millimeter, to satisfy the transverse beam quality requirements; an emission time on the order of a few ps is also required. This combination generally precludes the use of a metallic photocathode because the low quantum efficiency would

require a drive laser pulse with power densities approximating the ablation threshold.

The high emission current density requires extremely high electric field gradients at the cathode's surface to overcome the bunch's self-fields, which would otherwise limit the emitted current density or otherwise degrade the beam quality.

### Gun-Related Considerations

The cathode must be removable from the injector to allow introduction, replacement and refurbishment of the selected cathode. This means the cathode-to-gun RF joint must also withstand RF fields up to 140 MV/m for durations of at least 10  $\mu$ s, and potentially much longer if the MaRIE baseline linac design is made superconducting. [4]

## DESIGN REQUIREMENTS

Our initial experiments will characterize the effects of a MaRIE-relevant operating environment upon cathode dark current emission and quantum efficiency.

In broad terms, our research will address two questions: What will operating at the high gradients required over long RF pulses do to a semiconductor or multi-alkali cathode; and What will the cathode, operating at high gradient, do to the linac?

The former question relates primarily to the potential damage to the cathode from field-emission electrons and ions within the gun cavity, and to the nature and extent of changes to the surface and emission properties of the emitting surface from exposure to high gradients, both instantaneous and long-term.

The latter question relates to characterization of dark current from the cathode (and candidate RF joint designs), and to the potential for the cathode constituent elements to degrade the gun's ability to generate and sustain the required electric field gradients.

The cathode test cell design, therefore, must meet several primary design objectives:

- It must provide MaRIE-relevant RF gradients (140 MV/m) and pulse durations (10  $\mu$ s or longer);
- It must provide multiple viewports to both image and direct a photocathode drive laser onto candidate cathodes; and
- It must facilitate ready removal and replacement of candidate photocathodes.

Secondary design objectives include:

- It must be modular, to allow rapid and inexpensive modifications, upgrades or repairs; and
- It must demonstrate successful, low-field-emission operation of the cathode-to-gun RF joint.

\* Work supported by the US Department of Energy

† Approved for public release: LA-UR-14-26438

# jwlewellen@lanl.gov

## CATHODE TEST CELL DESIGN

### RF Cavity Design

While initial baseline for the MaRIE linac was a normal-conducting S-band (2.856 GHz) design, recent discussions have centered around using a superconducting L-band (1.3 GHz) linac as a means of providing longer RF macropulses. Either frequency choice raises issues for the MaRIE cathode test cell design. The design gradient should be more readily achievable at higher frequencies, particularly using a simple “pillbox” cavity. Klystrons capable of producing 10+  $\mu\text{s}$  pulses are more readily available at lower frequencies, however, they are often limited in RF power output, which would require using a re-entrant geometry to obtain the desired gradient.

The MaRIE cathode test cell frequency has been downselected to L-band, based primarily upon the availability of L-band klystrons capable of producing both the required macropulse duration, and sufficient RF power to produce the design gradient in a simple pillbox-type cavity. [5] The potential change to the MaRIE baseline RF frequency is a point in its favour, but not a decisive one.

The initial RF design of the test cell was completed using SUPERFISH [6] and is shown in Figure 1; the final RF design will be tuned and validated using CST Microwave Studio [7] after the mechanical design has been completed.

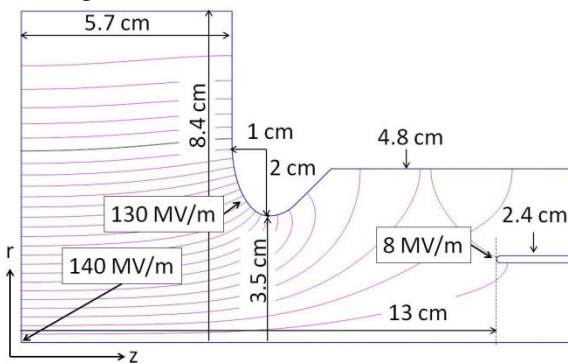

Figure 1: SUPERFISH model of MaRIE cathode test cell RF geometry, showing primary dimensions and selected field gradients.

The test cell makes use of an elliptical cross-section iris, and an on-axis RF power coupler. The iris radius has been selected as a compromise between shunt impedance and peak surface field. The coaxial RF power coupler radii have been chosen to transmit only the TEM coaxial waveguide mode at 1.3 GHz; other modes are cut off. While this is not, strictly speaking, necessary for the test cell itself, designing the coupler to transmit only the TEM mode allows us the potential of using the test cell to support measurements for which field symmetry is important, i.e. emittance measurements. Some of the cavity’s RF properties are listed in Table 1.

Table 1: RF Properties of the MaRIE Cathode Test Cell

Parameter	Value	Units
Shunt impedance	7.27	$\text{M}\Omega/\text{m}$
Q	14,334	
$P_{\text{in}}$	11.1	MW
$E_{\text{max,cath}}$	140	MV/m
$E_{\text{max,iris}}$	130	MV/m
$H_{\text{max}}$	225,202	A/m

### Beam Transport

While the test cell is not intended to be a high-brightness beam source in and of itself, we are interested in characterizing both field-emission and photoemission as a function of applied gradient. To that end, we have performed a series of simple beam transport simulations on the test cell to characterize electron trajectory as a function of launch phase and starting radial position, in the absence of space charge. Figure 2 shows the trajectories for launch phases of  $35^\circ$  and  $60^\circ$  past the zero-crossing, corresponding to “conventional” launch phase selections.

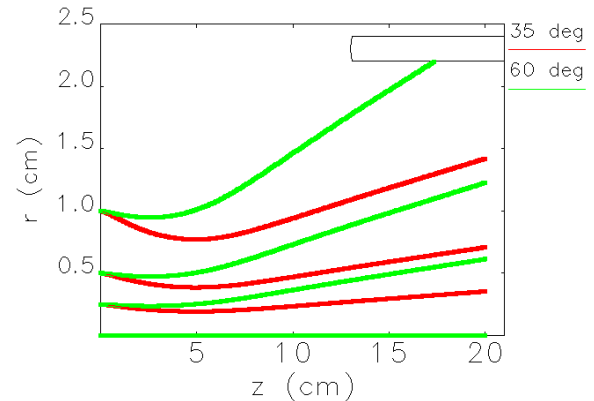

Figure 2: Trajectories for particles launched at 35 and 60 degrees past the zero crossing, emitted at 0.25, 0.5 and 1 cm radii.

Figure 3 shows trajectories for launch phases of  $10^\circ$ ,  $90^\circ$  and  $115^\circ$ , corresponding to a very early laser pulse, to the field-emission peak, and to close the the cutoff phase beyond which emitted particles cannot leave the test cell. In both figures, the bar in the upper right of the plot is the RF power coupler inner conductor. Finally, Figure 4 shows the kinetic energy of the particles as a function of position along the z-axis, for the launch phases shown in Figures 2 and 3.

Figure 5 shows anticipated field emission trajectories for electrons emitted at  $-90^\circ$  from the iris and from the end of the RF power coupler inner conductor. Impact energies on the cathode are anticipated to be at approximately 3 – 3.5 MeV when the on-cathode gradient is 140 MV/m.

### Mechanical Design

The design requirements for the MaRIE cathode test cell include a high degree of modularity. This reflects the

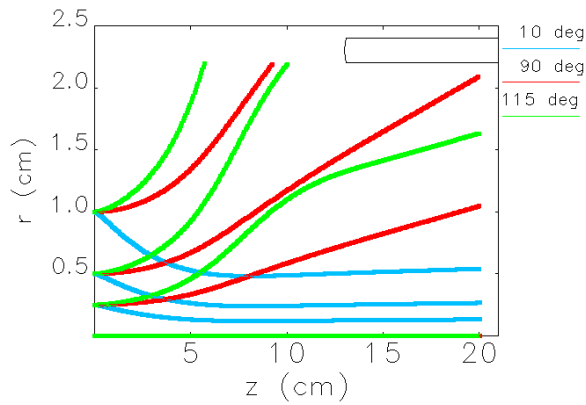

Figure 3: Trajectories for particles launched at 10, 90 and 115 degrees past the zero crossing.

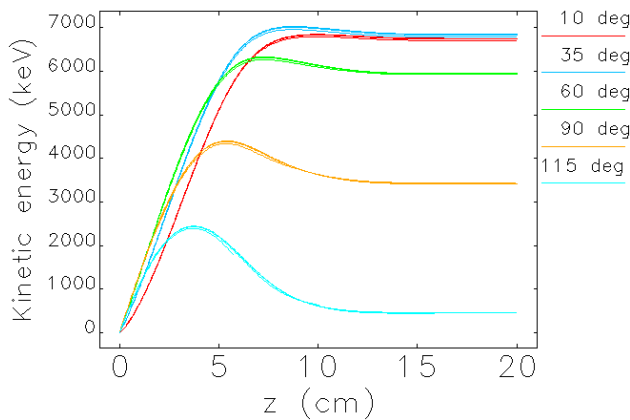

Figure 4: Kinetic energy vs. position for various launch phases.

challenging nature of the experiment, in particular the potential need to test multiple iterations of critical features such as the gun-to-cathode joint. It also drove the choice of on-axis RF power coupling, since separating the RF power feed from the body of the gun allows a lower-cost replacement of the entire cathode test cell proper, should this become necessary.

Figure 6 shows an overview of the design (left) and a close-up cut-away view of the interior of the RF cavity (right).

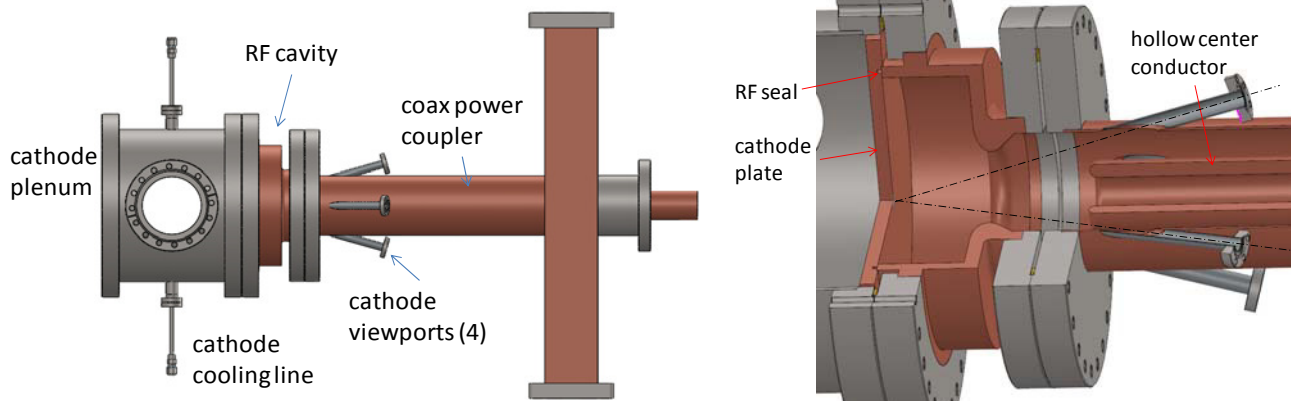

Figure 6: Mechanical design of the MaRIE cathode test cell: overall view (left) and close-up cut-away view (right).

The entire back wall of the RF cavity is removable, and has its RF seal separated from the vacuum seal. The removable back wall provides an inexpensive and easily modified platform for testing different cathode-to-gun joint designs.

The four cathode viewports are located symmetrically around the RF power coupler, with axes  $16^\circ$  from the axis of the power coupler. Each provides approximately a 1-cm diameter field of view at the cathode surface.

To characterize photoemission and dark current from the cathode, we envision placing an isolated viewscreen within the hollow center conductor of the RF power coupler approximately 20 cm from the cathode. The beam dynamics simulations suggest that a collector larger than  $\sim 2.5$  cm in diameter should collect all electrons emitted during “normal” launch phases from emission radii out to  $\sim 5$  mm (see Figure 2), the area we can address via the four viewports. Field emission (at  $90^\circ$ ) from radii less than  $\sim 0.75$  mm should be collected as well; this suggests that placing the cathode-to-gun RF seal at a radius of 1 cm or greater should help to isolate our diagnostics from field emission from the seal.

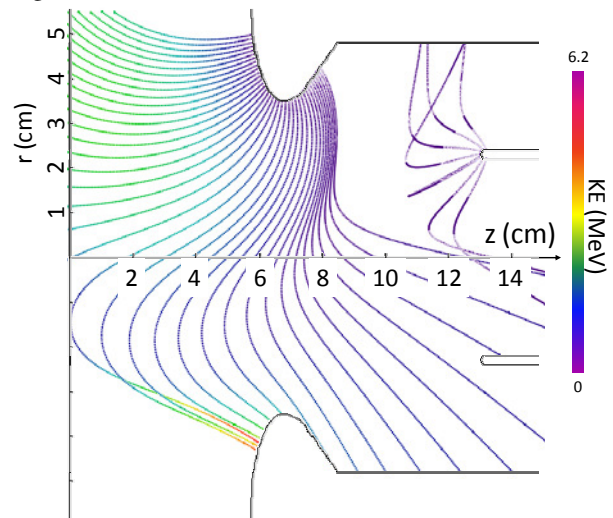

Figure 5: Field emission tracks from the iris and coupler end.

Copyright © 2014 CC-BY-3.0 and by the respective authors

Each 10- $\mu$ s, 11-MW RF pulse will deliver energy sufficient to raise the body of the gun, on average, by 0.04 K, so active water cooling is not required, but a water system (not shown) will be provided to temperature-stabilize the test cell as well as to permit frequency tuning.

The cathode plenum provides an interface to a cathode fabrication, characterization and loadlock system, not shown here. It also provides means for pumping the area around the cathode plate, and to provide water cooling to the cathode plate if necessary.

### *Design Alternatives*

The primary design risk, other than the cathode-to-gun RF seal, is achieving the design gradient with available RF power. At present, we intend to partner with the Argonne Wakefield Accelerator (AWA) to perform these tests. AWA includes among its facilities an L-band klystron capable of producing a 20-MW RF pulse for  $\sim 10$   $\mu$ s, which easily meets our baseline design's requirements.

If required, however, a re-entrant nosecone and / or cathode plate should provide the design gradient with as little as 4 MW of RF power. Implementing this alternative scheme should require re-fabricating only the cathode cell body and cathode plate and, potentially, a redesign of the in-coupler electron diagnostics.

## SCHEDULE AND VENUE

The mechanical and RF design is presently at approximately the 80% completion level, and we anticipate beginning construction of the test cell in late 2014. Initial RF testing will concentrate on achieving the design gradient in the gun, including validation of the cathode-to-gun RF seal. This shall be followed by characterizing the quantum efficiency and field-emission behavior of candidate cathodes as a function of their exposure to RF fields at various gradients and pulse durations. Finally, we intend to perform in-situ characterization of cathode performance within the MaRIE cathode test cell.

At present, we intend to perform the tests in collaboration with the Argonne Wakefield Accelerator group, starting in early- to mid-2015. In addition to the klystron mentioned above, the AWA facility incorporates vault space and photocathode drive laser options; and the personnel have extensive familiarity with related accelerator and cathode physics issues.

## DISCUSSION AND CONCLUSIONS

Next-generation X-ray free-electron lasers, including the MaRIE 40-kV X-FEL, will place increasing demands on the performance of the electron beam source arising from increasingly tight beam-quality requirements at the undulator. The beam sources, and cathodes in particular, will be required to operate at higher gradients, for longer RF pulse durations, with higher laser pulse energies and emitted charge densities.

We have designed a cathode test cell to help evaluate the performance of candidate cathode materials under conditions similar to those expected within a notional MaRIE-class injector. The test cell has been designed using a modular approach, so all major components are separately replaceable. We have elected to have a completely removable back wall for the RF cavity, allowing us the ability to test different cathode-to-gun RF seal methods without replacing the entire cavity.

Four viewports placed on the RF power coupler permit observation of the center of the cathode plate over a field-of-view of approximately 1 cm. The viewports can be used for imaging, photocathode drive laser introduction, or arc monitoring.

An electrically isolated imaging screen, can be placed within the hollow inner conductor of the RF power coupler. This placement will help us to separate out photocurrent and dark current arising from the cathode, from dark current from the RF seal, providing the RF seal radius is greater than 1 cm.

## ACKNOWLEDGEMENTS

We wish to thank the Argonne Wakefield Accelerator group, in particular John Power, for insightful discussions regarding L-band klystron capabilities and currently operating high-gradient L-band structures.

## REFERENCES

- [1] Y. Ding et al., "Measurements and Simulations of Ultralow Emittance and Ultrashort Electron beams in the Linac Coherent Light Source," *Phys. Rev. Lett.* 102, 254801, 24 June 2009.  
DOI: 10.1103/PhysRevLett.102.254801
- [2] B.E. Carlsten et al., "MaRIE X-Ray Free-Electron Laser Pre-Conceptual Design," *Proc. 2011 Part. Accel. Conf.*, p. 799, New York, NY.
- [3] Private communication, S. Russell, LANL, 2014.
- [4] Private communication, B.E. Carlsten, LANL, 2014.
- [5] Private communication, J. Power, ANL, 2014.
- [6] J.H. Billen and L.M. Young, "Poisson Superfish," LA-UR-96-1834, revised 13 January 2006.
- [7] <https://www.cst.com/Products/CSTMWS>