

THz PUMP AND X-RAY PROBE DEVELOPMENT AT LCLS*

Alan S. Fisher^{1#}, Hermann Dürr^{2,3}, Aaron Lindenberg^{2,3,4}, David Reis^{2,3,5},
Josef Frisch¹, Henrik Loos¹, Mark Petree¹, Dan Daranciang⁶, Matthias Fuchs^{3,5},
Shambhu Ghimire³ and John Goodfellow⁴

¹Linac Coherent Light Source

²Stanford Institute for Materials and Energy Science

³PULSE Institute for Ultrafast Energy Science

SLAC National Accelerator Laboratory, Menlo Park, CA 94025, USA

⁴Department of Materials Science and Engineering

⁵Department of Applied Physics

⁶Department of Chemistry

Stanford University, Stanford, CA 94305, USA

Abstract

We report on measurements of broadband, intense, coherent transition radiation at terahertz frequencies, generated as the highly compressed electron bunches in LCLS pass through a thin metal foil. The foil is inserted at 45° to the electron beam, 31 m downstream of the undulator. The THz emission passes downward through a diamond window to an optical table below the beamline. A fully compressed 350-pC bunch produces up to 0.5 mJ in a nearly half-cycle pulse of 50 fs FWHM with a spectrum peaking at 10 THz. We estimate a peak field at the focus of over 2.5 GV/m. A 20-fs Ti:sapphire laser oscillator has recently been installed for electro-optic measurements. We are developing plans to add an x-ray probe to this THz pump, by diffracting FEL x rays onto the table with a thin silicon crystal. The x rays would arrive with an adjustable time delay after the THz. This will provide a rapid start to user studies of materials excited by intense single-cycle pulses and will serve as a step toward a THz transport line for LCLS-II.

INTRODUCTION

The terahertz (THz) frequency range, from 1 mm to 10 μm (0.3 to 30 THz), occupies the gap between millimetre waves and the mid-infrared. It has been perhaps the least exploited part of the electromagnetic spectrum, mostly due to a lack of good sources and a corresponding lack of optical components and detectors. There has been significant recent progress in generating THz with lasers, using optical rectification from tilted pulse fronts [1,2,3], laser-produced plasmas in gases [4,5], and difference frequency mixing of phase-locked optical parametric amplifiers [6,7]. This has stimulated work in such diverse applications as the coherent atomic-scale control of materials and the exploration of novel nonlinear responses [8,9,10,11]. These techniques typically produce broadband 10- μJ pulses with peak fields of 100 MV/m for a single temporal peak (“quasi-half-cycle”) [1,2,3,4] and up

*Work supported by the United States Department of Energy, Office of Science, under contract DE-AC02-76SF005.

#afisher@slac.stanford.edu

to 1 GV/m for few-cycle pulses [6,7].

Coherent transition radiation (CTR) from relativistic electron bunches has generated similar peak fields [12,13,14,15]. At the Linear Coherent Light Source (LCLS) x-ray FEL at SLAC National Accelerator Laboratory, studies of THz began in late 2010. Here we show that CTR from highly compressed (50 fs), high-charge (350 pC) electron bunches in LCLS generates quasi-half-cycle THz pulses over the band from 0.1 to 40 THz, with energies of 100 to 500 μJ and with peak electric fields of 2.5 GV/m.

Since the pulses reproduce the femtosecond scale of the electron bunch, the radiation is a useful diagnostic of these extremely short bunches. Moreover, the location of this source 31 m after the undulator provides a unique opportunity to excite a sample with a THz pump and then probe its response with an FEL x-ray pulse. The fields approach 1 V/Å, characteristic of atomic bonds. Both pump and probe have the femtosecond time scale of material responses, and with inherently low relative jitter. We will present our concept for a simple pump-probe setup on the optical table used for THz characterization.

THE LCLS THz SOURCE

Layout

The CTR source is a thin metal foil. To ensure radiation safety for users downstream in the experimental hutches, the foil thickness should be below 10 μm over a span of 25 mm horizontally and 18 mm vertically, corresponding to a circular foil of 25 mm tilted at 45°. A tighter limit on foil thickness comes from avoiding substantial attenuation of LCLS x rays. Initially we used a 2- μm beryllium foil; this was recently replaced with 0.5 μm of aluminium. A pneumatic actuator inserts it at 45° to the beam so that the CTR from electrons approaching the foil radiates downward through a polycrystalline diamond window 25 mm in diameter and 250- μm thick. A gold-coated off-axis parabolic mirror (OAP) below the window collimates the light. Due to the sensitivity of its alignment, motors enable 5-axis remote adjustment of the OAP (3 trans-

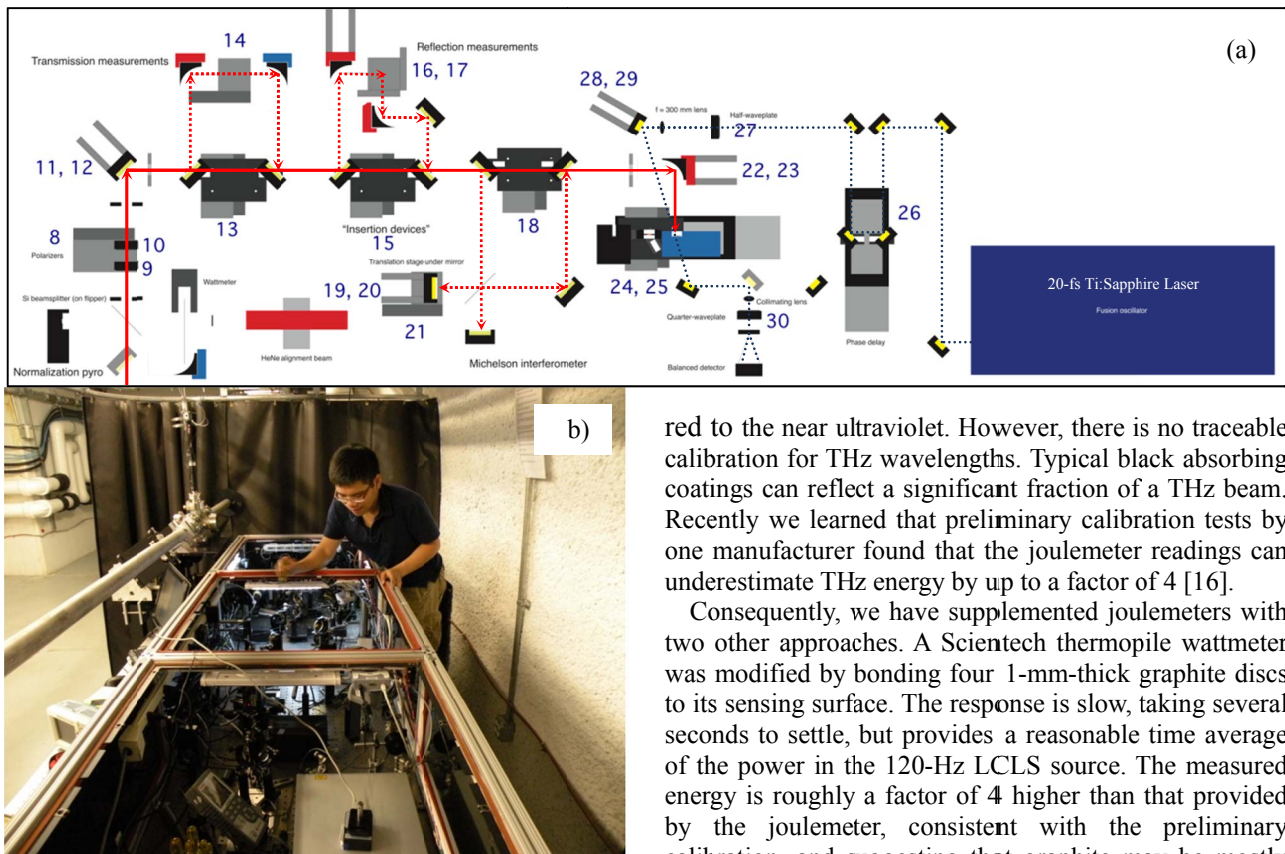

Figure 1: (a) Layout of optics on the THz table. The THz (red lines) enters at the lower left. (b) LCLS electron and x-ray beams travel through the beampipe above the optical table in the LCLS undulator hall. The cross at the far end of the table holds the actuator that inserts the THz foil, with the exit window below. The THXPP project will go on the empty table space directly below the beamline.

lations and 2 tilts). Two flat gold-coated mirrors, one with tilt motors, then redirect the light across an optical table below the beamline (Fig. 1(b)).

The optics beyond this point have changed for different measurements. Figure 1 shows the newest layout, which accompanied the installation of a 20-fs titanium-sapphire laser for electro-optic measurements. The optical configuration is flexible, with ample remote controls and cameras. The major portion of the table is covered in a light-tight enclosure, both for laser safety and to allow a dry-air purge to remove water vapour, which has many absorption lines in the THz range. However, the measurements reported here were made without this purge, through an optical path of 1 to 2 m of air at ordinary humidity.

Pulse Energy and Size at Focus

Thermal measurements are the standard way to obtain the energy in a laser pulse, and the same concept would seem appropriate for THz. Pyroelectric joulemeters are the most common tool, since they are fast, capable of repetition rates from 100 to 1000 Hz, and accurately calibrated over the wavelengths from the near infra-

red to the near ultraviolet. However, there is no traceable calibration for THz wavelengths. Typical black absorbing coatings can reflect a significant fraction of a THz beam. Recently we learned that preliminary calibration tests by one manufacturer found that the joulemeter readings can underestimate THz energy by up to a factor of 4 [16].

Consequently, we have supplemented joulemeters with two other approaches. A Scientech thermopile wattmeter was modified by bonding four 1-mm-thick graphite discs to its sensing surface. The response is slow, taking several seconds to settle, but provides a reasonable time average of the power in the 120-Hz LCLS source. The measured energy is roughly a factor of 4 higher than that provided by the joulemeter, consistent with the preliminary calibration, and suggesting that graphite may be mostly “black” at THz wavelengths. Our highest reading for a 350-pC, 45-fs pulse was 450 μ J.

An entirely different approach modifies the method used to measure the energy in LCLS x-ray pulses [17]. The bend at the beam dump provides a sensitive electron energy spectrometer. To spoil FEL gain, a corrector kicks the electrons as they enter the undulator, so that their orbit oscillates about the axis. The energy at the dump is monitored as the kick strength is scanned. The decrease in electron energy due to lasing provides the FEL energy.

To find the energy lost due to THz emission, the FEL is left unchanged, but the energy is measured as the foil is cycled in and out multiple times. We have observed a loss of up to 3 mJ (comparable to the FEL emission). However, the electrons radiate CTR both as they enter and exit the foil. Only the entrance radiation is directed toward our window, which reflects 30% of this energy due to its high refractive index. After allowing for water-vapour absorption and detector inefficiency, the result is consistent with the direct measurements of the THz beam.

A pyroelectric camera (Spiricon Pyrocam III) images the THz beam on a 124 \times 124 grid of 100 μ m pixels. When the camera was scanned through the focus of an OAP, a fit to the projections of the image gave a beam size of <500 μ m FWHM.

Autocorrelation

Autocorrelations of the THz beam are made with a Michelson interferometer. A silicon beamsplitter splits the collimated THz beam into two arms with retroreflection mirrors, one with a motorized delay that can be scanned

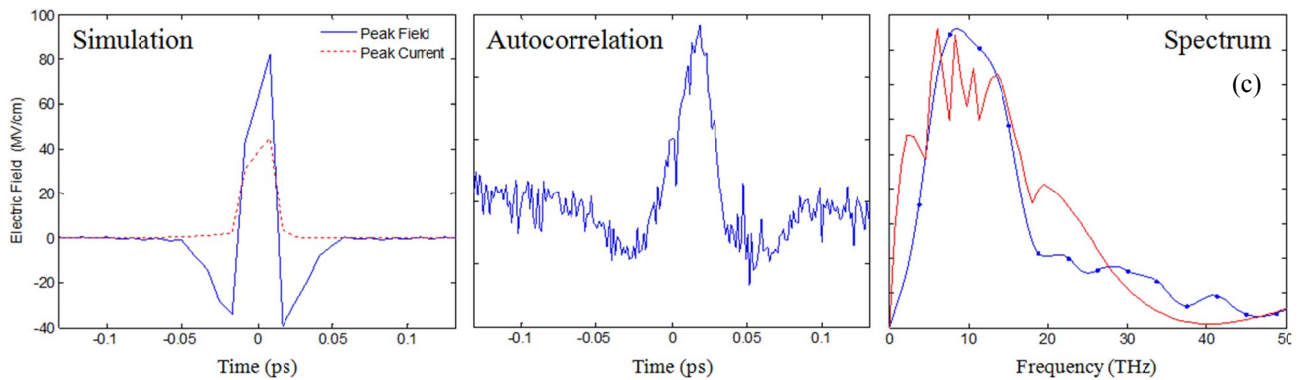

Figure 2: (a) Simulation of a linear (field) autocorrelation (blue solid line) of a fully compressed bunch (red dashed line). (b) Measured autocorrelation of a 50-fs FWHM. (c) Bunch spectrum, from the Fourier transform of the measured autocorrelation (red), and from the simulation (blue).

in 100-nm steps. An OAP focuses the recombined light into a detector. To correct for shot-to-shot fluctuations during scans, another silicon plate sends part of the entering beam to a joulemeter used for normalization. Figure 2 shows a scan of a fully compressed bunch, and the spectrum calculated by Fourier transform. The narrow bunches are shorter than the nominal 50 fs FWHM given by the LCLS bunch-length monitor: its cut-off is too low for the spectrum of these short bunches. Wider bunches are not Gaussian in time: after chirping and only partial compression, they exhibit two peaks (“horns”) that produce three peaks on an autocorrelation (Fig. 3).

Most scans used a second pyroelectric joulemeter to detect the interfering beams, giving a linear autocorrelation that ideally increases the signal by a factor of 2 at full overlap (but typically only 10 to 20%). Autocorrelations of lasers obtain far higher contrast by using the nonlinearity of a crystal that generates the second harmonic between two crossed beams. We have performed nonlinear THz autocorrelations (Fig. 3) with strong contrast using a silicon photodiode (Thorlabs PDA100A). These diodes show a strong response at the focus of our THz beam, despite having a photon energy well below the Si bandgap, 1.1 eV (270 THz).

Peak Fields

The pulse energy and the longitudinal and transverse profiles allow a calculation of the peak electric and magnetic fields. By modelling the THz pulse as a Gaussian with a transverse size of 400 μm FWHM and a duration of 40 fs FWHM, and by using a pulse energy of 500 μJ , we find a peak electric and magnetic fields of 7 GV/m and 23 T. More typical values of 100 μJ in a 500- μm , 50-fs pulse give 2.2 GV/m and 7.5 T.

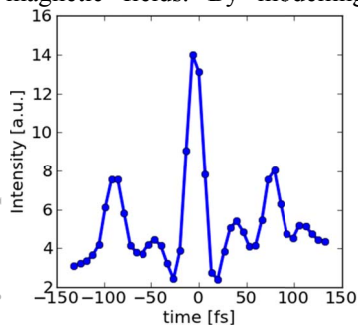

Figure 3: Autocorrelation of a 125-fs FWHM pulse using the nonlinear response of a silicon photodiode to intense THz.

ISBN 978-3-95450-117-5

THZ PUMP AND X-RAY PROBE

Transporting THz to the Users

These intense THz pulses are a natural complement to the FEL x rays travelling through the same beampipe, with the capability to provide a strong femtosecond pump prior to an x-ray probe. However, it is difficult to deliver the pump to a user in an LCLS hutch. An optical transport line to the Near Experimental Hall would be about 100 m long. Frequent reimaging with OAPs would be needed to avoid substantial diffractive broadening at these long wavelengths, in a design balancing the distance between mirrors against the size of the mirrors and transport pipe.

Because of this circuitous route to the hutch, the THz pump necessarily arrives about 100 ns *after* the x-ray probe, which follows a straight path. It is certainly difficult to add a comparable delay to the hard x-ray path, but we could instead use two electron bunches, the first for THz and the second for x rays. LCLS has performed an initial test of two-bunch operation to provide two x-ray pulses to users, but the electron diagnostics require upgrading to make this routine.

Moreover, both bunches generated x rays in the undulator. In a pump-probe setup, x rays from the first bunch would reach the user's sample before the THz pump. Even if the FEL gain were reduced or spoiled entirely for the first bunch, x rays from spontaneous emission may have an impact on an experiment.

The remedy is to kick the first bunch into a beamline that bypasses the undulator and has the THz foil. The second bunch goes through the undulator and produces x rays. This approach is under consideration for LCLS-II.

Bringing the Users to the THz Source

We have devised a way to start pump-probe experiments while avoiding these complexities. Figure 4 shows the concept for the THz X-ray Pump-Probe project (THXPP). A thin silicon Bragg crystal diffracts hard x rays downward onto the optical table, about 3 m downstream of the THz foil. The x rays exit the beamline vacuum through a beryllium window and are then

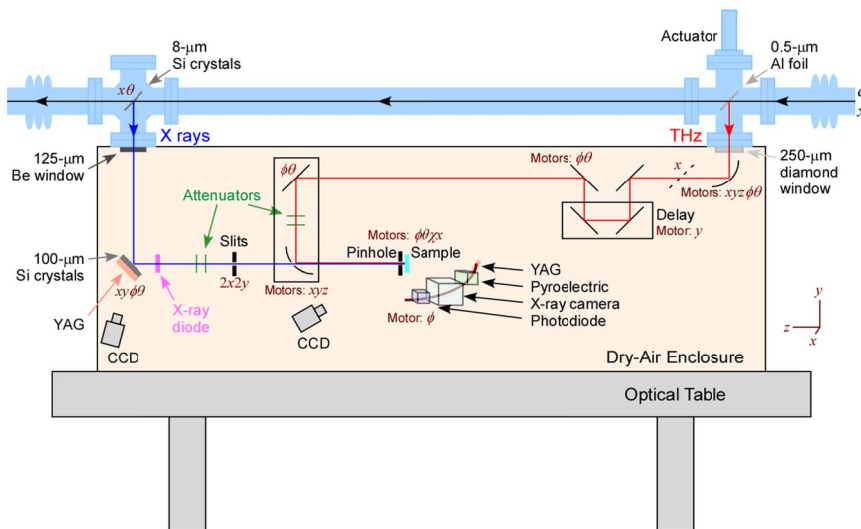

Figure 4: Layout of the proposed THz X-Ray Pump-Probe project.

diffracted by a second crystal. After making a full U-turn, they travel horizontally to the user's sample.

The THz, now extracted at the upstream end of the table, also makes a U-turn, but its path is shorter and so arrives at the sample first. An adjustable path delay allows for precise timing. The scheme needs no transport line, and only one electron bunch. The pump-probe timing is inherently free of jitter.

As with the foil, radiation safety considerations limit the thickness of the first Bragg crystal to 8 μm over a 25-mm diameter. The thickness is sufficient to fully diffract x rays within the rocking curve of silicon, while transmitting those outside this narrow band with minimal attenuation. Since the FEL bandwidth is over an order of magnitude wider than the diffraction width, the THz project can share the photon beam during hard x-ray

delivery to users whose experiments can tolerate a notch in the spectrum, such as those using a monochromator.

To accommodate sharing and to perform a variety of pump-probe experiments, the crystal angle must be tuned through a range of photon energies. However, the U-turn restricts the angle, since the x rays exit the second crystal horizontally only for a Bragg angle of 45°. Some accommodation is possible by adjusting the height of the second crystal and of the sample. By translating a "ladder" of three crystals, and by rocking the ladder over a range of 45° ± 1.25°, it is possible to span a broad energy range:

- Si(442): 7.59 to 8.28 keV
- Si(333): 8.05 to 8.78 keV
- Si(440): 8.76 to 9.56 keV

Crystals can be made with the required thickness by etching the central 25 mm of a 50-mm silicon wafer. Thin crystals are also needed for another LCLS project, the Large Offset Monochromator (LOM), which will allow experiments to share a hard x-ray beam. This instrument has begun commissioning.

THXPP has already undergone a review of the concept and of the scientific case, based on a wide range of demonstration experiments. After the LOM successfully completes commissioning, we anticipate authorization to proceed. Until then, we are continuing THz measurements and will shortly begin THz/laser experiments.

REFERENCES

- [1] A. Stepanov, L. Bonacina, S. Chekalin, and J.-P. Wolf, *Opt. Lett.* **33**, 2497–2499 (2008).
- [2] H. Hirori, A. Doi, F. Blanchard, and K. Tanaka, *Appl. Phys. Lett.* **98**, 091106 (2011).
- [3] K.-L. Yeh, M.C. Hoffmann, J. Hebling, and K.A. Nelson, *Appl. Phys. Lett.* **90**, 171121 (2007).
- [4] T. Bartel, P. Gaal, K. Reimann, M. Woerner, and T. Elsaesser, *Opt. Lett.* **30**, 2805–2807 (2005).
- [5] K. Kim, A. Taylor, J. Glowina, and G. Rodriguez, *Nat. Photonics* **2**, 605–609 (2008).
- [6] A. Sell, A. Leitenstorfer, and R. Huber, *Opt. Lett.* **33**, 2767–2769 (2008).
- [7] F. Junginger, A. Sell, O. Schubert, B. Mayer, D. Brida, M. Marangoni, G. Cerullo, and R. Huber, *Opt. Lett.* **35**, 2645–2647 (2010).
- [8] M.C. Hoffmann, J. Hebling, H.Y. Hwang, K.-L. Yeh, and K.A. Nelson, *Phys. Rev. B* **79**, 161201 (2009).
- [9] H. Wen, M. Wiczer, and A. Lindenberg, *Phys. Rev. B* **78**, 125203 (2008).
- [10] T. Qi, Y. Shin, K. Yeh, K. Nelson, and A. Rappe, *Phys. Rev. Lett.* **102**, 247603 (2009).
- [11] P. Gaal, W. Kuehn, K. Reimann, M. Woerner, T. Elsaesser, and R. Hey, *Nature* **450**, 1210–1213 (2007).
- [12] M. Gensch et al., *Infrared Phys. Technol.* **51**, 423–425 (2008).
- [13] J. van Tilborg, C. Schroeder, C. Tóth, C.G.R. Geddes, E. Esarey, and W.P. Leemans, *Opt. Lett.* **32**, 313–315 (2007).
- [14] J. Park, C. Kim, J. Lee, C. Yim, C.H. Kim, J. Lee, S. Jung, J. Ryu, H.-S. Kang, and T. Joo, *Rev. Sci. Instrum.* **82**, 013305 (2011).
- [15] S. Casalbuoni, B. Schmidt, P. Schmußer, V. Arsov, and S. Wesch, *Phys. Rev. ST Accel. Beams* **12**, 030705 (2009).
- [16] D. Dooley, Gentec, private conversation.
- [17] P. Emma et al., *Nature Photonics*, 2010.176.