

PERFORMANCE OF THE RF CAVITY BPM AT XFEL/SPRING-8 “SACLA”

Hirokazu Maesaka[#], Hiroyasu Ego, Takashi Ohshima, Tsumoru Shintake, Yuji Otake,
 RIKEN SPring-8 Center, 1-1-1 Kouto, Sayo-cho, Sayo-gun, Hyogo, Japan
 Shin'ichi Matsubara, JASRI/SPring-8, 1-1-1 Kouto, Sayo-cho, Sayo-gun, Hyogo, Japan
 Shinobu Inoue, SPring-8 Service Co. Ltd., 1-20-5 Kouto, Shingu-cho, Tatsuno-shi, Hyogo, Japan

Abstract

We have developed and constructed an rf cavity beam position monitor (RF-BPM) system for the XFEL facility at SPring-8, “SACLA”. The demanded position resolution of the BPM is less than 1 μm, because an electron beam and x-rays must be overlapped within 4 μm precision in the undulator section. A C-band (4.760 GHz) RF-BPM was employed to achieve this requirement. In total, fifty seven RF-BPMs were produced and installed into SACLA. Before installation, some basic performances, such as resonant frequency and Q factor for each RF-BPM, were measured and confirmed to be sufficient for precise position detection. We then evaluated the position resolution by using a 7 GeV electron beam having a 0.1 nC bunch charge. The position resolution of the RF-BPM in the undulator section was less than 0.6 μm, which was sufficient for the XFEL lasing.

INTRODUCTION

The x-ray free-electron laser (XFEL) facility “SACLA” (SPring-8 Angstrom Compact Free Electron Laser) started operation in February, 2011, and succeeded in XFEL lasing at a wavelength of 0.12 nm in June, 2011 [1]. To achieve a SASE (Self-Amplified Spontaneous Emission) FEL in an x-ray region, the electron beam must be precisely overlapped with x-rays throughout an undulator section. The overlap accuracy is required to be 4 μm [2] for SACLA. Therefore, a precise beam position monitor (BPM) with a position resolution of less than 1 μm is demanded.

In SACLA, a C-band rf cavity BPM (RF-BPM) is employed in order to satisfy sub-μm resolution. A prototype of an RF-BPM system was tested at the SCSS test accelerator, and its resolution to observe the position of an electron beam having a bunch charge of 0.3 nC and a beam energy of 250 MeV was confirmed to be 0.2 μm [3]. This system was then mass-produced and installed into SACLA. In total, fifty seven RF-BPMs were utilized in both the accelerator and the undulator sections of SACLA, as illustrated in Fig. 1. Before installation, the

resonant frequency, Q factor, etc. of each RF-BPM cavity were confirmed to be satisfactory. During the XFEL commissioning, the position resolution of the RF-BPM system was evaluated.

In this paper, we describe the design and the construction of the RF-BPM system and the result from a position resolution measurement using an electron beam.

OVERVIEW OF THE RF-BPM SYSTEM

We briefly mention the detection principle of an RF-BPM, and describe the design of the RF-BPM system of SACLA.

The RF-BPM uses a TM110 dipole resonant mode in a cylindrical cavity to measure the beam position. The amplitude of the output rf signal from the TM110 cavity can be written as [4]

$$V = V_1qx + jV_2qx' + jV_3q + V_n, \quad (1)$$

where q , x and x' are the beam charge, the beam position and the slope of the beam trajectory, respectively. V_1qx is the in-phase component proportional to the beam position, jV_2qx' is the quadrature-phase component coming from the beam slope, jV_3q is also the quadrature-phase component due to leakage of the parasitic monopole mode, such as TM010, and V_n are the other components, such as a thermal noise. To obtain beam position information, we have to scale the signal with the beam charge and determine the phase origin for the extraction of the in-phase component. Therefore, an additional TM010 mode cavity is required for the RF-BPM to provide charge and phase information.

Based on the concepts mentioned above, we designed the RF-BPM illustrated in Fig. 2. For the TM110 cavity, the rf signal is picked up through a coupling slot that is decoupled to the TM010 monopole mode in order to minimize the third term of Eq. 1 (jV_3q). The resonant frequency is 4.760 GHz for both the TM110 and TM010 cavities. Although the acceleration rf frequency is 5.712 GHz, the BPM frequency is intentionally shifted so as to avoid any background due to the dark current

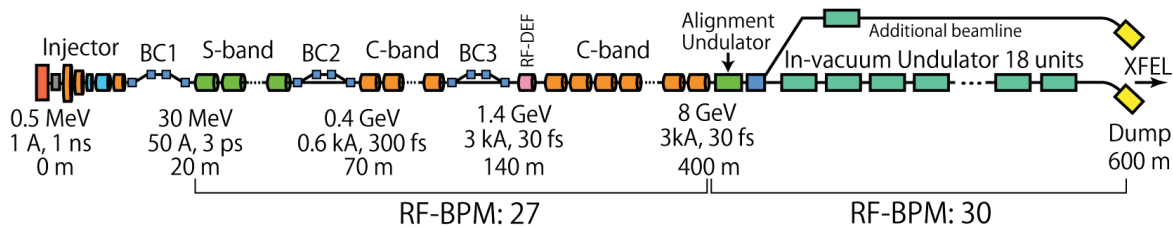

Figure 1: Schematic view of SACLA and the number of RF-BPMs.

[#]maesaka@spring8.or.jp

synchronized with an acceleration rf field of 5712 MHz.

Some other parameters of the RF-BPM are summarized in Table 1. The Q factor and the signal amplitude were calculated from the results of three-dimensional rf simulations with HFSS [5]. The loaded Q factor (Q_L) is 45 and the unloaded Q factor (Q_0) is approximately 600. This Q_0 value is about ten-times smaller than that of an oxygen-free copper cavity, because the RF-BPM cavity is made of stainless steel having a poor electric conductivity. Since the Q_L of our cavity is much smaller than Q_0 , the Q_0 value of several hundred is sufficient for our BPM.

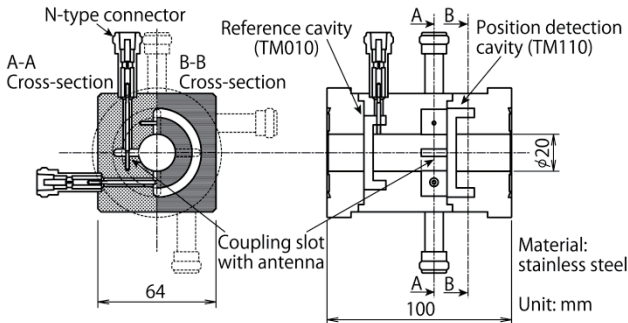

Figure 2: Drawing of the RF-BPM cavity.

Table 1: Design Parameters of the RF-BPM Cavity

	TM110 cavity	TM010 cavity
Resonant frequency [GHz]	4.760	4.760
Loaded Q factor (Q_L)	45	45
Unloaded Q factor (Q_0)	600	570
Number of ports	4 (X: 2, Y: 2)	1
Signal amplitude at the 50 ohm port	14 mV/ $\mu\text{m/nC}$ (peak)	200 V/nC (peak)

The RF-BPM signal is processed by an IQ (In-phase and Quadrature) demodulator (IQ-DEM), as shown in Fig. 3. The rf signal from the RF-BPM is fed into an attenuator switch so as to extend the dynamic range, because the required value is 100 dB (from sub- μm to a few mm), while the dynamic range of the IQ-DEM is 60 dB. The phase delay of each attenuator is adjusted to within a few degrees. Baseband signals from the IQ-DEM are recorded by VME A/D converters [6] having a 238 MHz sampling rate. The resolution of the A/D converter is 12 bits for the accelerator section and 16 bits for the undulator section. These electronics are inserted into a temperature-stabilized 19-inch enclosure, and are powered by a low-noise DC power supply in order to reduce any thermal drift and electric noise [7].

Mass-production of the RF-BPM system started in 2007, and was completed in 2010. Components of the RF-BPM cavity were precisely machined with 10 μm accuracy, and were bonded together by a brazing method. The resonant frequency was checked before and after the brazing process. The produced cavities were installed into

the SACLA facility, as shown in Fig. 4. The RF-BPM system has been working well since the beginning of its operation.

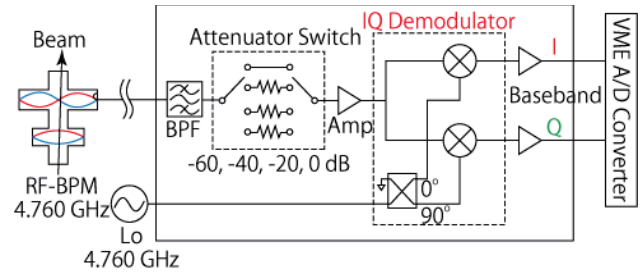

Figure 3: Block diagram of the RF-BPM electronics.

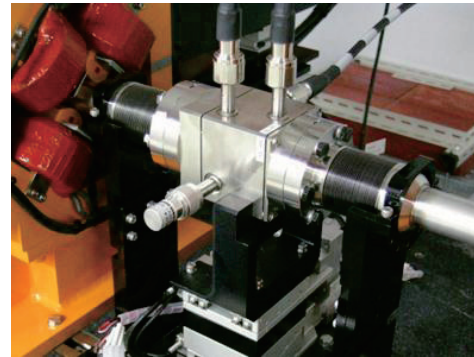

Figure 4: Photograph of an RF-BPM cavity after installation.

PERFORMANCE OF THE RF-BPM

In this section, we describe basic performances of the RF-BPM cavity and the electric circuits, which were measured before installation. We then evaluate the sensitivity and the resolution of the RF-BPM in the undulator section determined by using an electron beam.

Quality of the RF-BPM Cavity

The resonant frequency and the Q factor of each RF-BPM cavity were measured with a network analyser. Figure 5 shows a histogram of the resonant frequencies of the TM110 and TM010 cavities. The resonant frequency distributes around 4.760 GHz and the maximum deviation is 0.015 GHz. Since the frequencies of all of the BPM cavities are within the bandwidth of the detection electronics (0.03 GHz), the BPM signals are appropriately processed by the electronics.

The unloaded and loaded Q factors are shown in Fig. 6. The Q factors are consistent with the design values summarized in Table 1 and, therefore, the quality of the cavities is sufficient for position detection. However, some of the unloaded Q factors are slightly larger than the design value. This is because the electric conductivity of the actual cavity is considered to be slightly better than that of the rf simulation.

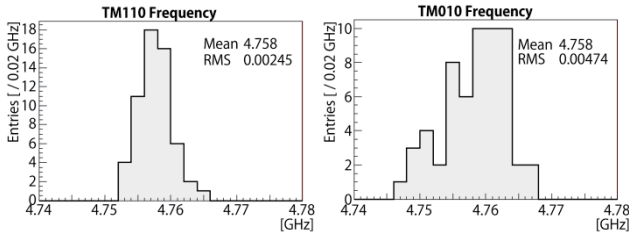

Figure 5: Histograms of the resonant frequencies of TM110 cavities (left) and TM010 cavities (right).

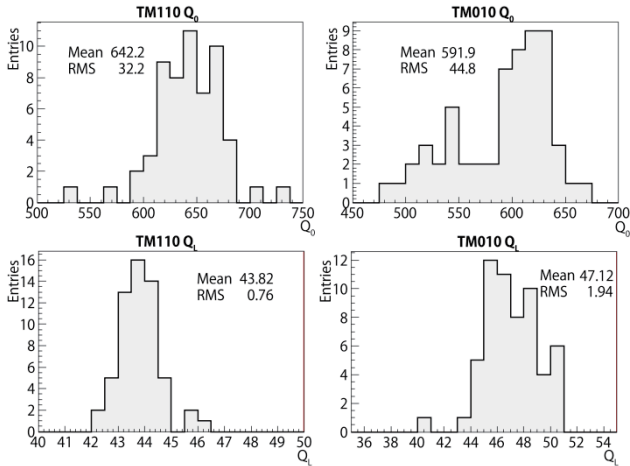

Figure 6: Histograms of unloaded Q factors (upper) and loaded Q factors (lower) of TM110 cavities (left) and TM010 cavities (right).

Performance of the Detection Electronics

The basic performance of the detection electronics was tested with a CW rf signal before installation. The amplitude linearity error of the electronics was less than 1%. The phase error was less than 0.5 degree when the input rf voltage was 70% of the full scale, as shown in Fig. 7. In this figure, an input rf phase was scanned with a 10-degree step, and the difference between the set phase and the detected phase was plotted. The obtained performance is sufficient for the beam-position measurement in SACLA.

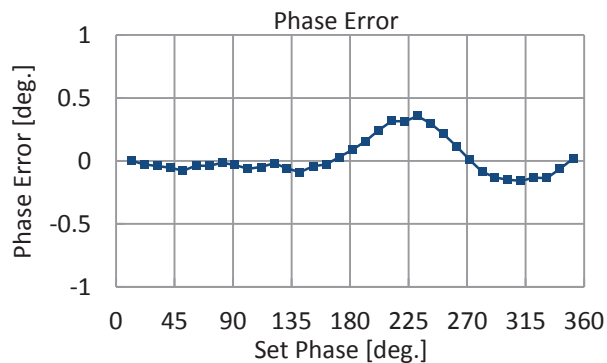

Figure 7: Phase error of the IQ demodulator circuit.

Position Sensitivity

We obtained the position sensitivity of the RF-BPM in the undulator section by using a 7-GeV electron beam with a 0.1 nC bunch charge. Since the RF-BPM in the undulator section is mounted on a movable stage, the signal amplitude as a function of the stage position was measured. The relationship between the signal voltage and the BPM position is plotted in Fig. 8. In this figure, the phase origin was corrected by using the TM010 cavity, and hence the signal voltage means the first term of Eq. 1 (in-phase component). In this measurement, the attenuator switch was set to 0 dB (highest sensitivity). The sensitivity was measured to be approximately 3 V/mm. Since the full scale of the ADC is ± 1 V, the maximum range of the beam position is ± 0.3 mm.

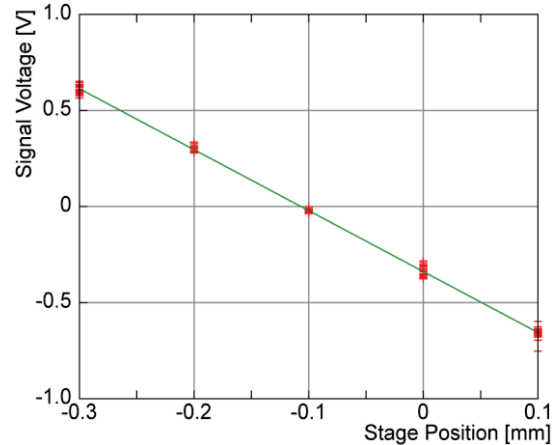

Figure 8: Voltage of the RF-BPM signal as a function of the RF-BPM position. A linear function fitted to the data is also plotted.

Position Resolution

The position resolution of an RF-BPM can be evaluated from the difference between a measured position and an estimated position from other neighboring BPMs. We analyzed the resolutions of 20 RF-BPMs in the undulator section. In order to estimate the beam position at a given RF-BPM, the data of the other 19 RF-BPMs were used. Although the position resolution analysis can be performed with three BPMs, the estimated position has significant uncertainty coming from the position resolution of each BPM. This uncertainty can be reduced by a factor of $1/\sqrt{N}$, where N is the number of BPMs utilized for the position estimation. This factor is $1/\sqrt{19} \sim 0.23$ in our case, which is significantly smaller than $1/\sqrt{2} \sim 0.71$ in the three-BPM case. The beam position of a given RF-BPM for each beam shot was estimated by a least-squares method. In this analysis, constraints coming from transfer matrices were imposed on a beam trajectory and the position and the slope of the beam at the given RF-BPM were determined so as to reproduce the other BPM data.

Suppose that the position resolution of the i -th BPM is analyzed. When the transfer matrix from j -th BPM to i -th

is denoted by $F(j, i)$, the position and the slope of a beam at the i -th BPM (x_i, x'_i) and those at the j -th one (x_j, x'_j) have the relationship

$$\begin{pmatrix} x_j \\ x'_j \end{pmatrix} = F(j, i) \begin{pmatrix} x_i \\ x'_i \end{pmatrix}. \quad (2)$$

Here, we define the measured position of the j -th BPM as \tilde{x}_j . In order to obtain a least squares solution of (x_i, x'_i) , the square sum of the difference between the measured position and the estimated position,

$$J = \sum_{j(j \neq i)} (\tilde{x}_j - x_j)^2, \quad (3)$$

must be minimum. Therefore, the solution can be obtained from the following system of equations

$$\frac{\partial J}{\partial x_i} = \frac{\partial J}{\partial x'_i} = 0. \quad (4)$$

Thus, the beam position at the i -th BPM is precisely estimated.

By using an electron beam with a 0.1 nC bunch charge and 7 GeV beam energy, we analyzed the position resolution of the RF-BPM in the undulator section. One of the correlation data between the measured position and the estimated one is plotted in Fig. 9. The measured position is almost the same as the estimated position with 1 μm precision. We define the position resolution as the rms of the difference between the measurement and the estimation. The result of the position resolution analysis is shown in Fig. 10. The position resolution of the RF-BPM in the undulator section was less than 0.6 μm . This result satisfies the demand of SACLA.

CONCLUSIONS

We designed and constructed a C-band (4.760 GHz) RF-BPM system to achieve a sub- μm resolution required for SACLA. Some basic performances of the RF-BPM system, such as the resonant frequencies and the Q factors were confirmed before installation. By using a 7 GeV electron beam having a 0.1 nC bunch charge, we measured the position resolution of the RF-BPM in the undulator section. The position resolution was less than 0.6 μm , which was sufficient for SACLA. The RF-BPM system greatly contributed toward SASE amplification of x-rays with a wavelength of around 0.1 nm.

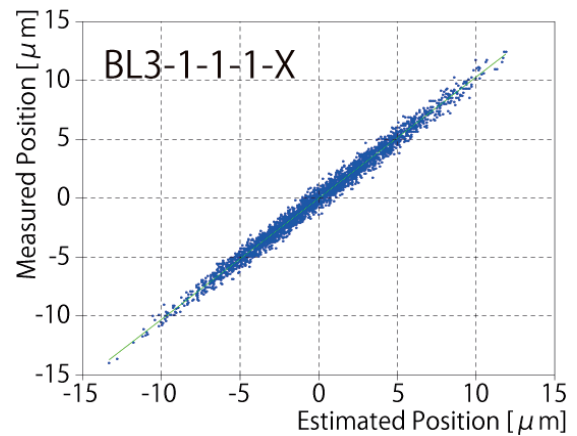

Figure 9: Scatter plot of the measured position of a BPM versus the estimated position from other BPMs.

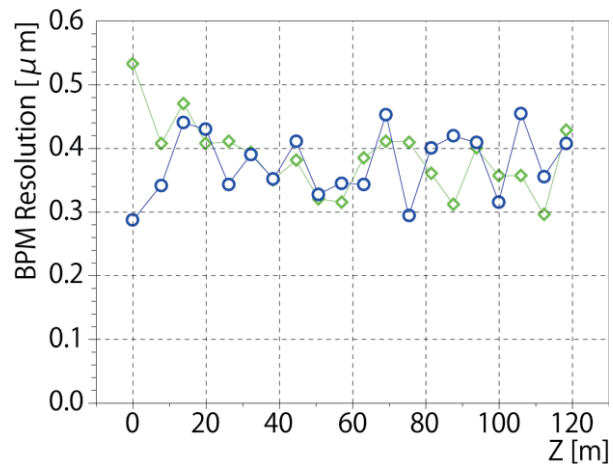

Figure 10: Position resolution data of 20 RF-BPMs in the undulator section. Blue circles are the X resolutions and green diamonds are the Y resolutions. The horizontal axis shows the RF-BPM location along the beam direction.

REFERENCES

- [1] H. Tanaka, "SACLA (XFEL/SPring-8) Project Status of Beam Commissioning", in these proceedings.
- [2] T. Tanaka, H. Kitamura and T. Shintake, Nucl. Instrum. Meth. A 528, 172 (2004).
- [3] H. Maesaka, *et al.*, "Development of the RF Cavity BPM of XFEL/SPring-8", Proceedings of DIPAC'09 (2009).
- [4] T. Shintake, "Development of Nanometer Resolution RF-BPMs", Proceedings of HEAC'99 (1999).
- [5] <http://www.ansoft.com/products/hf/hfss/>
- [6] T. Fukui, *et al.*, "A Development of High-speed A/D and D/A VME Boards for a Low Level RF System of SCSS", Proceedings of ICALEPCS'05 (2005).
- [7] N. Hosoda, *et al.*, "Construction of a Timing and Low-level RF System for XFEL/SPring-8", Proceedings of IPAC'10 (2010).