

ERL for Low Energy Electron Cooling at RHIC (LEReC)

Jörg Kewisch, Dmitri Kayran, Michael Blaskiewicz,
Christoph Montag, Alexei Fedotov

ERL 2015

June 7-12, 2015

BROOKHAVEN
NATIONAL LABORATORY

a passion for discovery



Abstract

- The Low-energy RHIC electron Cooler (LEReC) system has been approved to be build at the Brookhaven National Laboratory. The electron cooling system will be able to deliver an electron beam of adequate quality in a wide range of electron beam energies (1.6-5 MeV). While existing electron coolers use a DC electron beam this will be the first application of using a bunched electron beam provided by an ERL, paving the way for future electron coolers at higher energies.



Low Energy RHIC Physics program: Search for QCD phase transition Critical Point

Center of mass energies: $\sqrt{s_{NN}} = 5, 6.3, 7.7, 8.8, 11.5, 14.6, 19.6, 27$ GeV

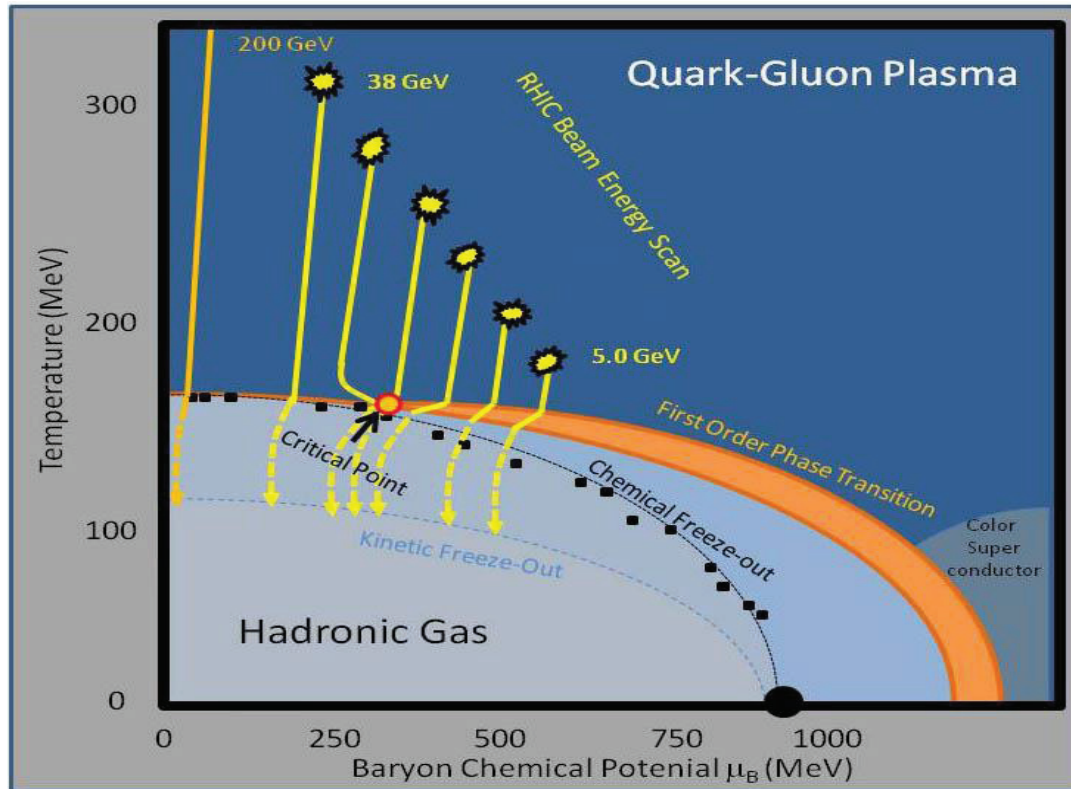

- Energies in black have been measured in the 2010 & 2011 & 2014 RHIC runs
- Because of large emittance and IBS at low energies the integrated luminosity is small
- We need to cool the ions to improve luminosity



Electron cooling

- Inject an electron beam into the ion beam
- Both beams travel in the same space and direction with the same speed. γ is the same for both beams $E_{electrons} = E_{ions} \cdot \frac{m_e}{m_i}$
- Imagine an electron beam has zero emittance and energy spread. Then in the co-moving frame :
 - The electrons are at rest
 - The ions lose energy by Coulomb scattering
- In the real world the friction force in the co-moving frame is

$$\vec{F} = -\frac{4\pi n_e e^4 Z^2}{m} \int \ln\left(\frac{\rho_{\max}}{\rho_{\min}}\right) \frac{\vec{V} - \vec{v}_e}{|\vec{V} - \vec{v}_e|^3} f(v_e) d^3 v_e$$



LEReC beam structure in cooling section

Example for $\gamma=4.1$ ($E_{ke}=1.6$ MeV)

Electrons:

$f_{\text{SRF}}=703.518\text{MHz}$

Rms length=3 cm, $I_{\text{peak}}=0.4$ A

$Q_e=100$ pC

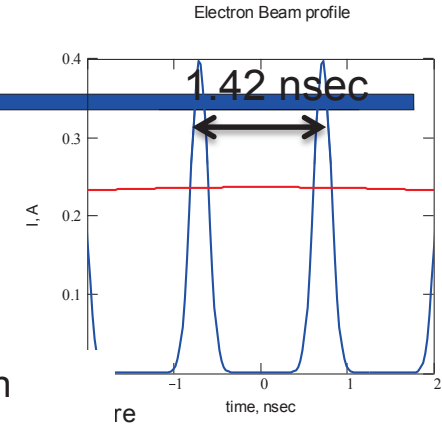

9 MHz RHIC RF LEReC Beam Structure

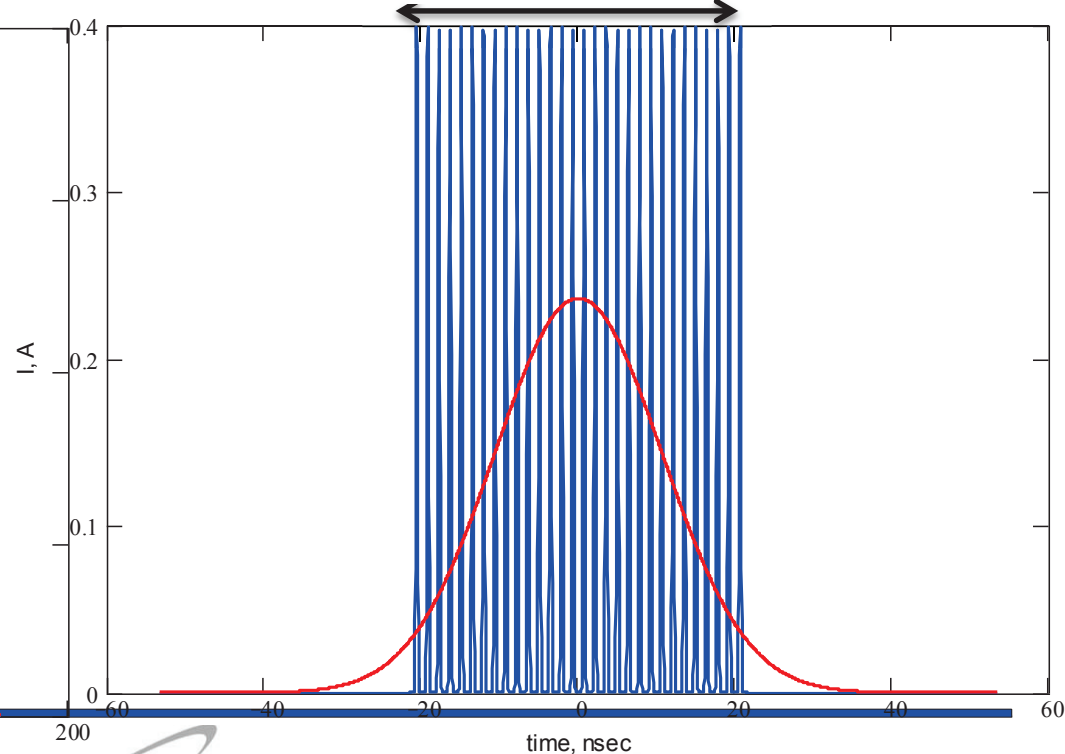
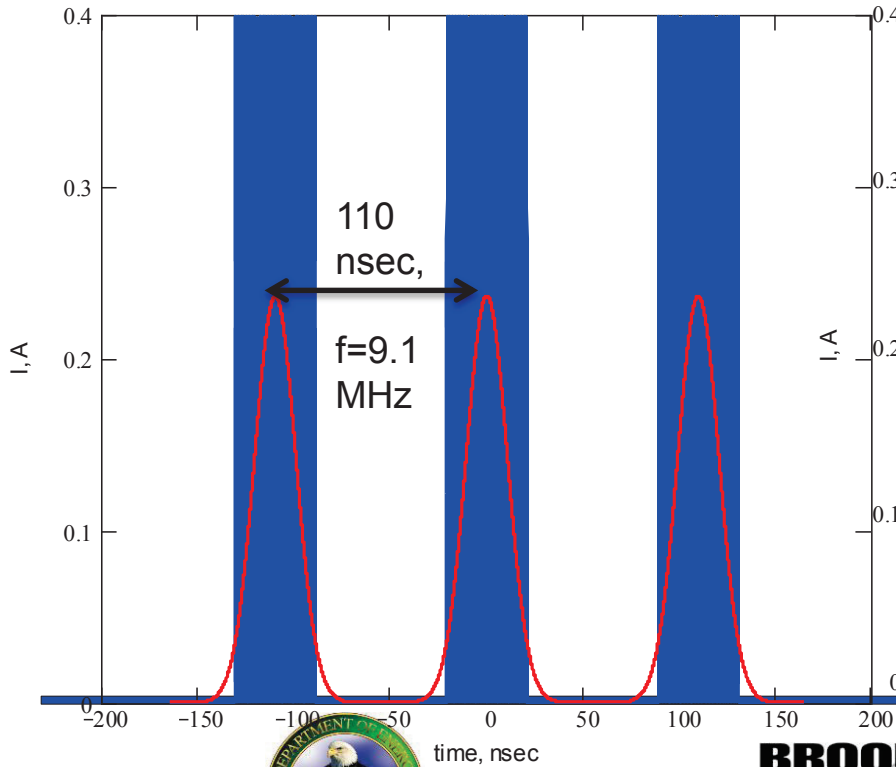

BROOKHAVEN
NATIONAL LABORATORY

Office of
Science
U.S. DEPARTMENT OF ENERGY

July 9-11 2014

Requirements

Energy [MeV]	Gamma	Charge per bunch [pC]	Bunches per bunch train	Beam Current [mA]
1.58	4.10	100	30	30
2.04	5.00	100	30	30
2.65	6.18	150	24	33
3.48	7.80	200	21	40
4.85	10.50	300	18	50

	Parameters need for ultimate cooling performance
Normalized rms emittance	$< 2.5e-6$ m
RMS energy spread	$5e-4$



LEReC Phase-I: Gun-to-dump mode

electron beam energies 1.6-2MeV

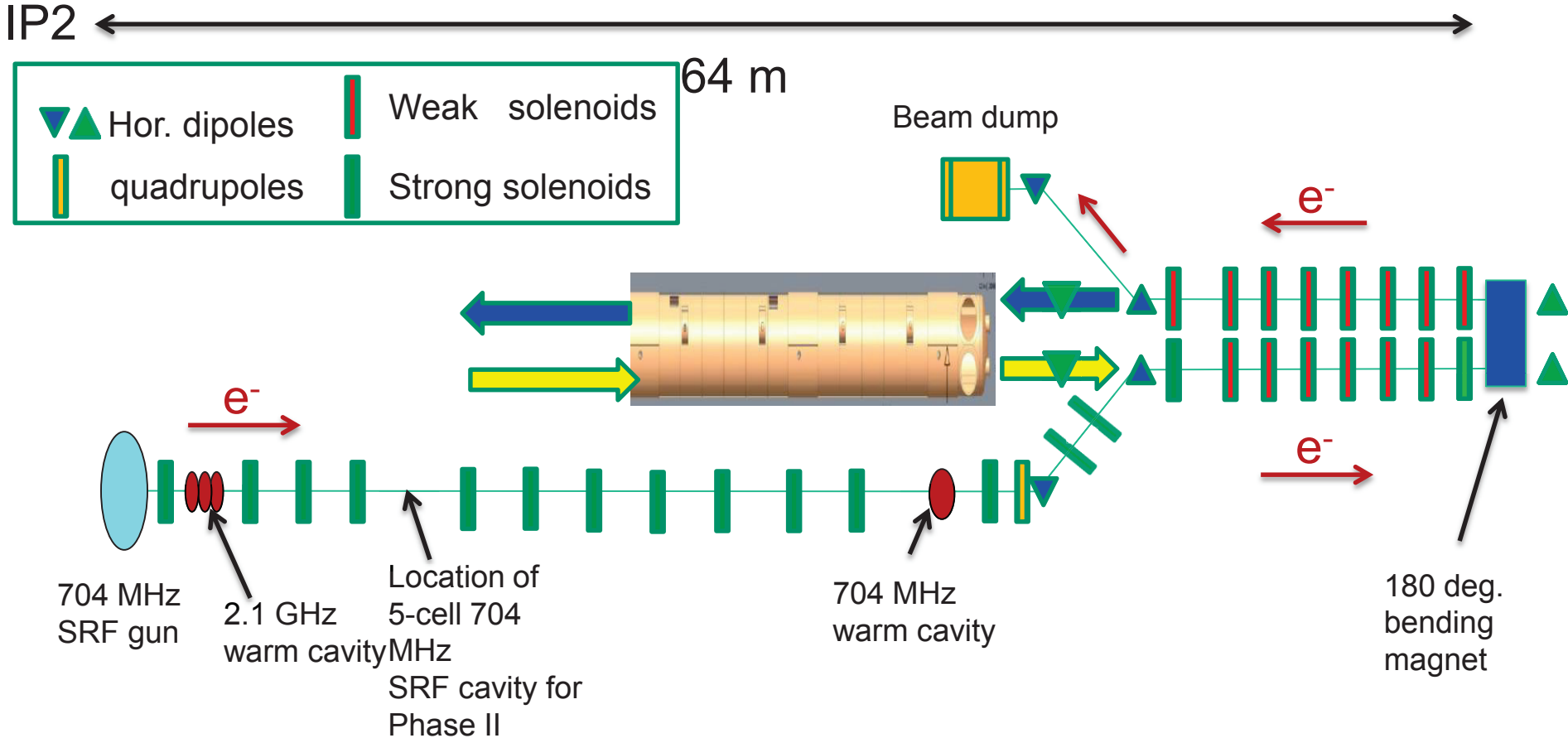

LEReC Phase-I: Gun-to-dump mode

electron beam energies 1.6-2MeV

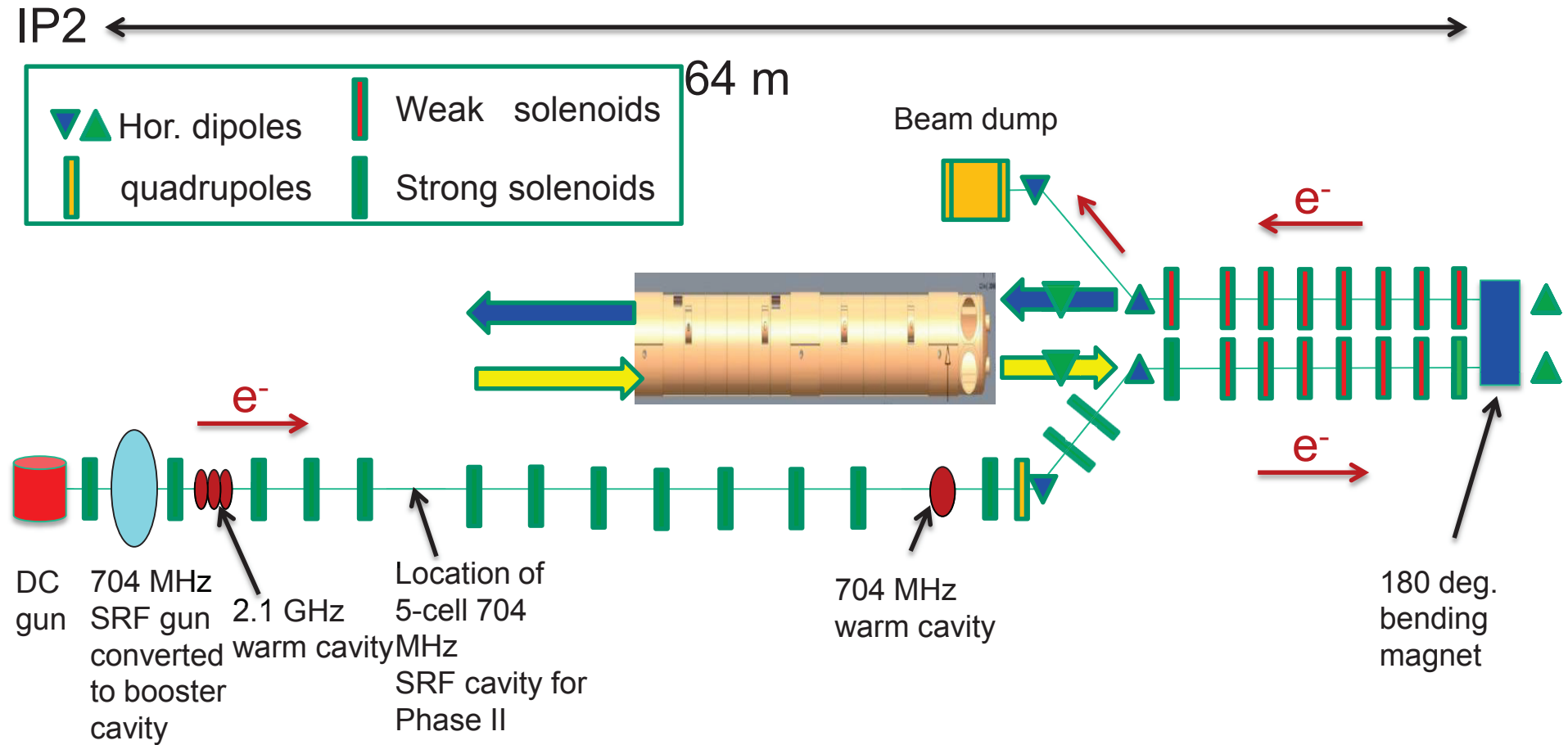

LEReC Phase-II : ERL mode

electron beam energies 2.7 – 5 MeV

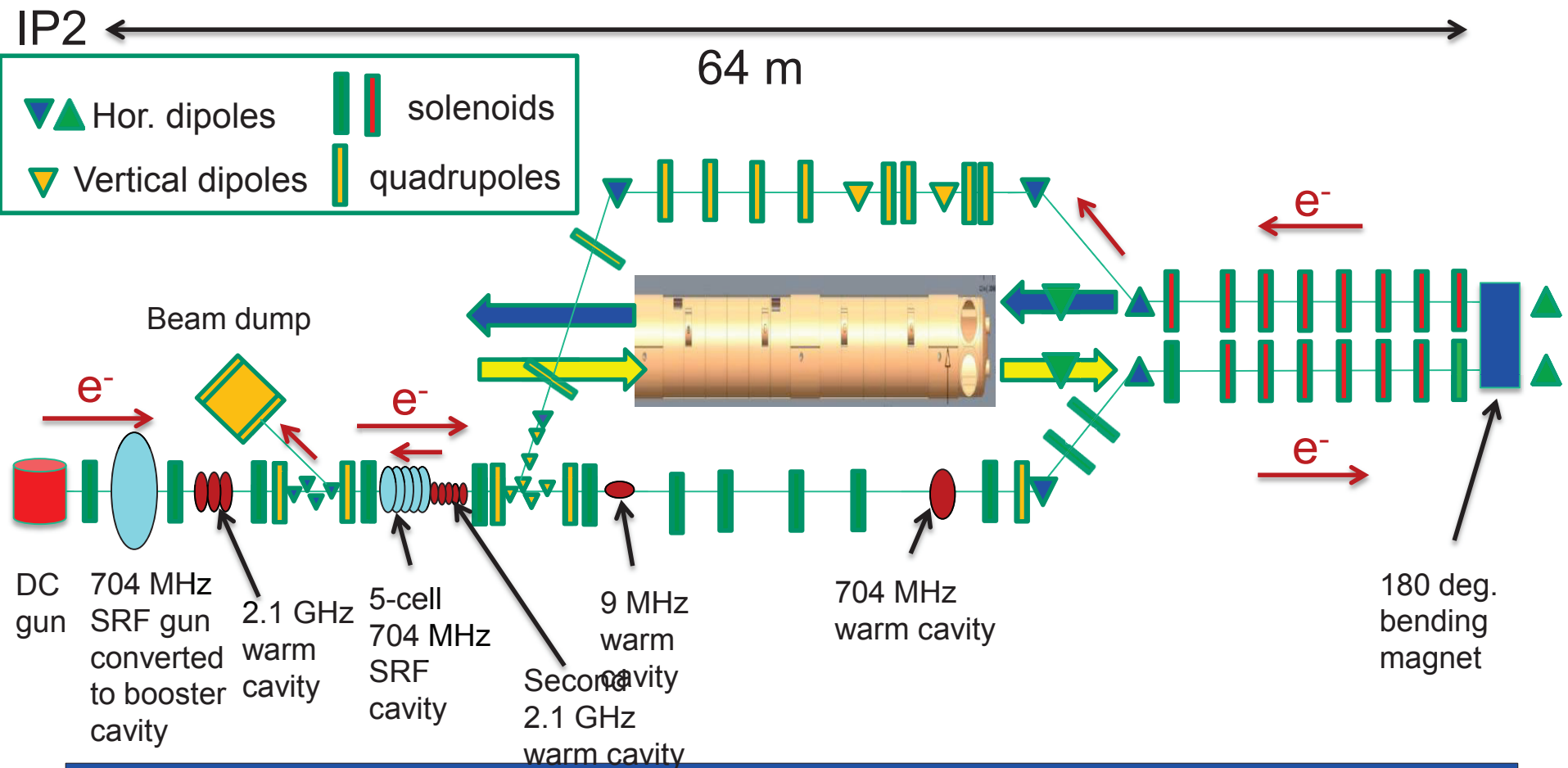

BROOKHAVEN
NATIONAL LABORATORY

Office of Science
U.S. DEPARTMENT OF ENERGY

July 9-11 2014

Layout

- DC gun provides beams up to 0.4 MeV
- SRF Booster provides beams up to 2 MeV
 - also used to create energy chirp for stretching of the bunches
- Warm 2100 MHz cavity removes 2nd order energy chirp.
- Zig-Zag merger (Kayran-Litvinenko) avoids emittance blow-up
- 5 Cell SRF cavity accelerates up to 5 MeV in Phase II
 - also used to create energy chirp for stretching of the bunches
- 2nd Warm 2100 MHz cavity removes 2nd order energy chirp.
- SRF gun and 5 cell cavity are too high to be located in the tunnel.
- Warm 700 MHz cavity removes linear energy chirp



Layout

- Dog leg section for merging with the ion beam
 - uses chevron magnets to keep the beam round
 - 2 solenoids to make the dog leg achromatic
- Strong solenoids before and after dog leg adjust beam size in the cooling section
- Weak solenoids in the cooling sections minimize the beam divergence
- A single 180 degree (non achromatic) turn-around dipole degrades the emittance less than an achromatic beam line.
- Return of the beam and energy recovery passing through the 5cell cavity and the 2nd 2100 MHz cavity to the dump
- ‘Push-Pull’ deceleration



LEReC timeline



SRF gun:

2015-2016: SRF gun commissioning w/beam with new cathode stalk.
High-current commissioning in CW mode (LEReC tests in 912).

DC gun:

May 2015 – mid 2016: DC gun construction by Cornell University.
2016: DC gun commissioning at Cornell.
Conversion of the SRF gun into the booster cavity

End of 2015: Start of cooling sections installation
2016: Start installation of electron beam transport and warm RF cavities

June 2017 – Feb.2018: Move and install SRF Gun, SRF cavity, beam dump, etc.

End of 2017-March 2018: Systems commissioning (RF, cryogenics, etc.)

April - Sept 2018: LEReC commissioning with e-beam in RHIC tunnel

October 2018: RHIC Run-19 BES-II physics program (commissioning of cooling with Au ion beams). RHIC Run-20 BES-II program (LEReC Phase-II)





Higher brightness require larger fields at the cathode surface

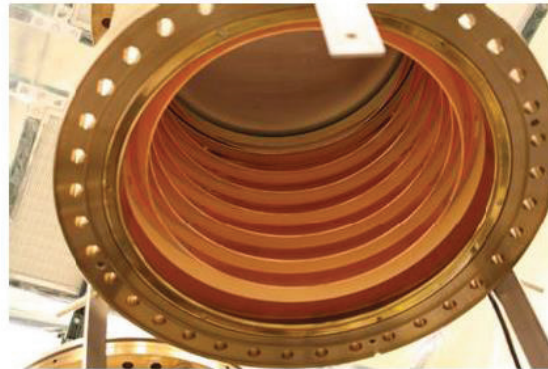
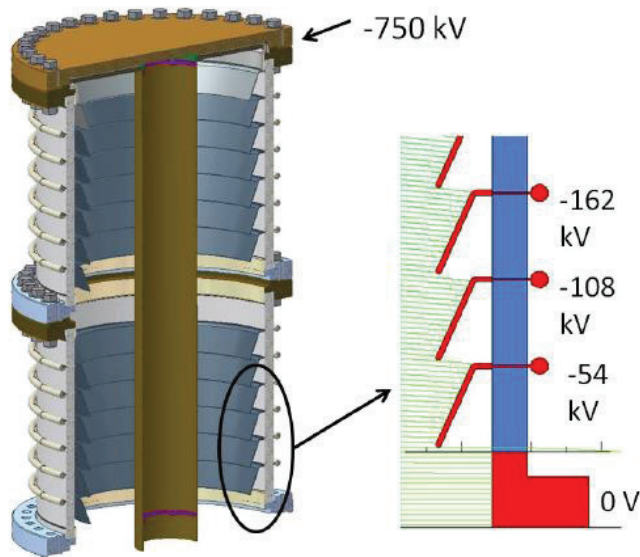

We designed a segmented insulator with intermediate guard rings to catch any field emitted electrons before they reach the insulator material.

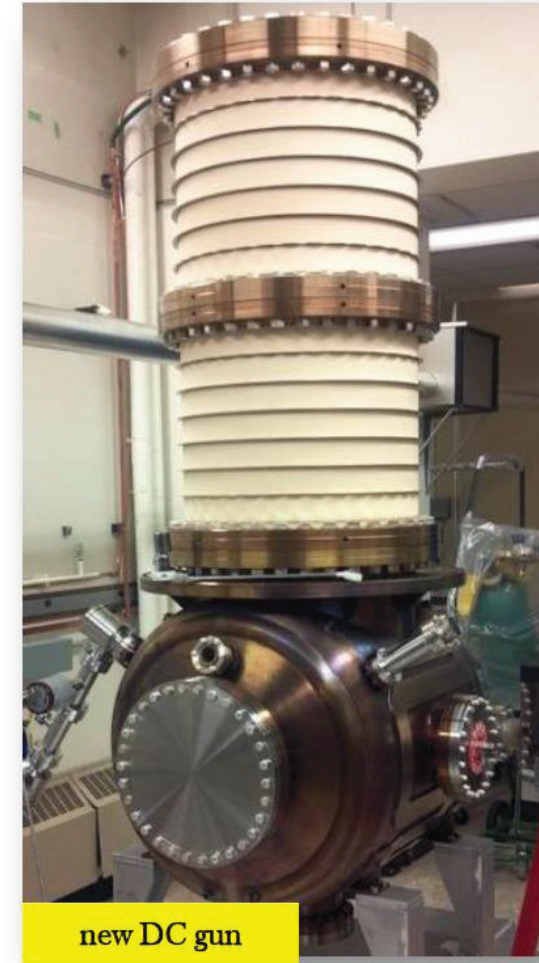
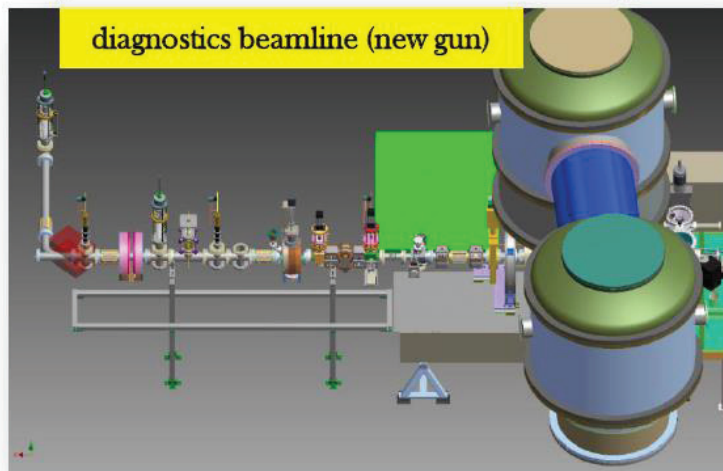

Layout for the above simulation

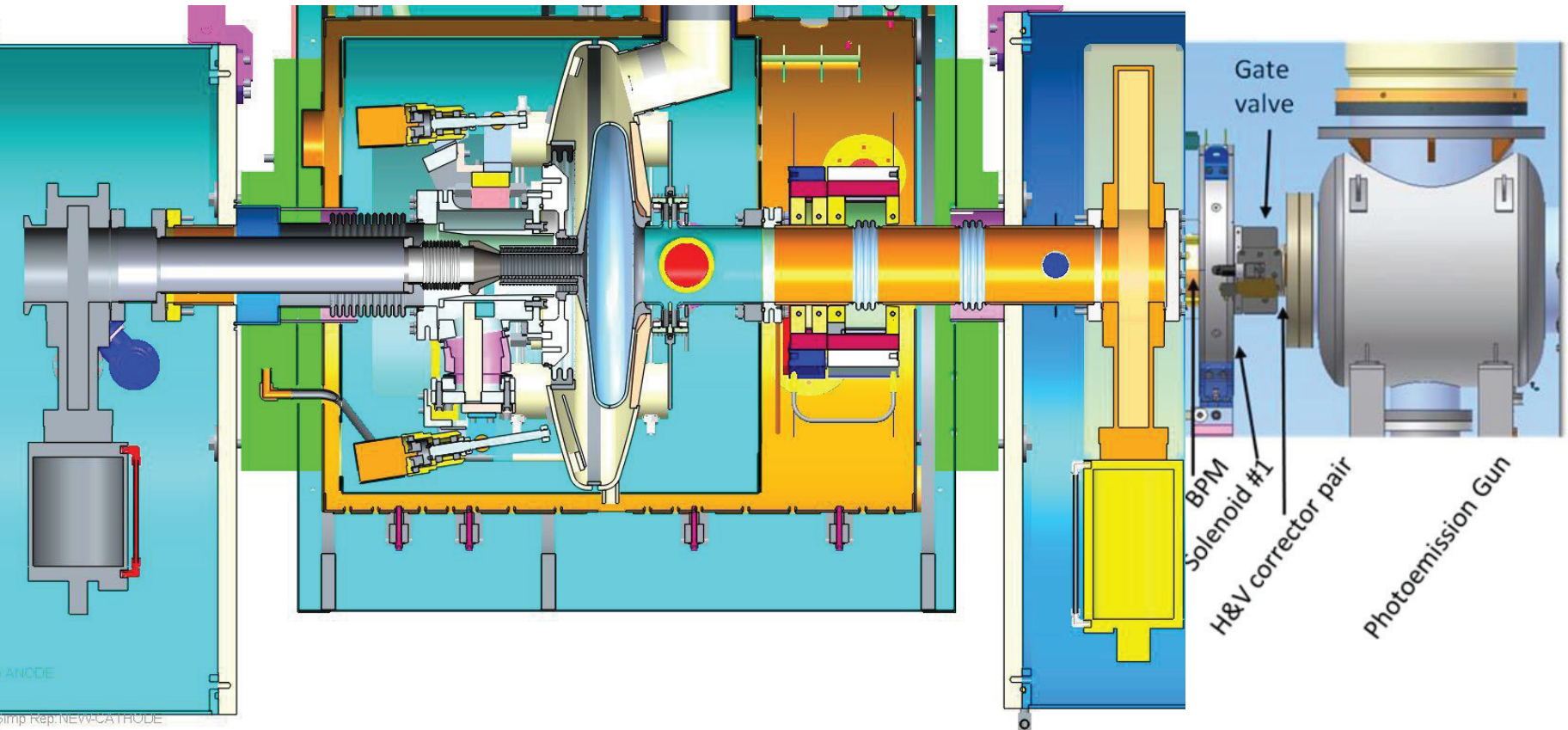

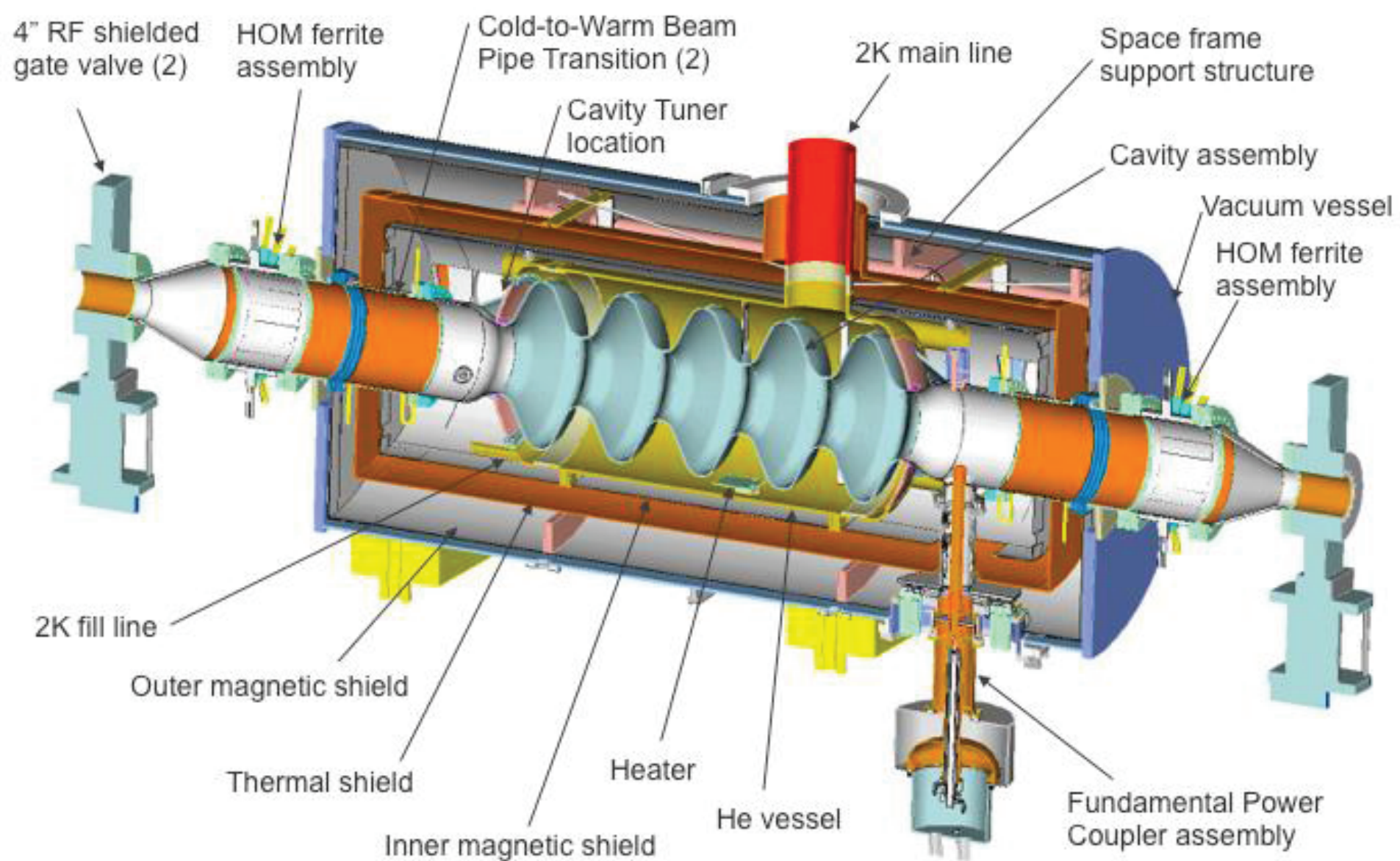

Simulations

- All simulations were made using the code PARMELA (LANL)
- PARMELA is a 2-D program that assumes for the space charge calculations that the beam is round. Since we keep our beams round PARMELA is an appropriate tool
- A multi-threaded optimizing program (written at BNL) was used which launches PARMELA for the function evaluation
- The following results at 1.6 MeV are 130 pC bunches are tracked, and 100 pC (with the lowest energy deviation) are used for the evaluation of the beam parameters
- Unexpected jumps in the functions are the result of using a different subset of electrons



Emittances

LEReC with DC gun

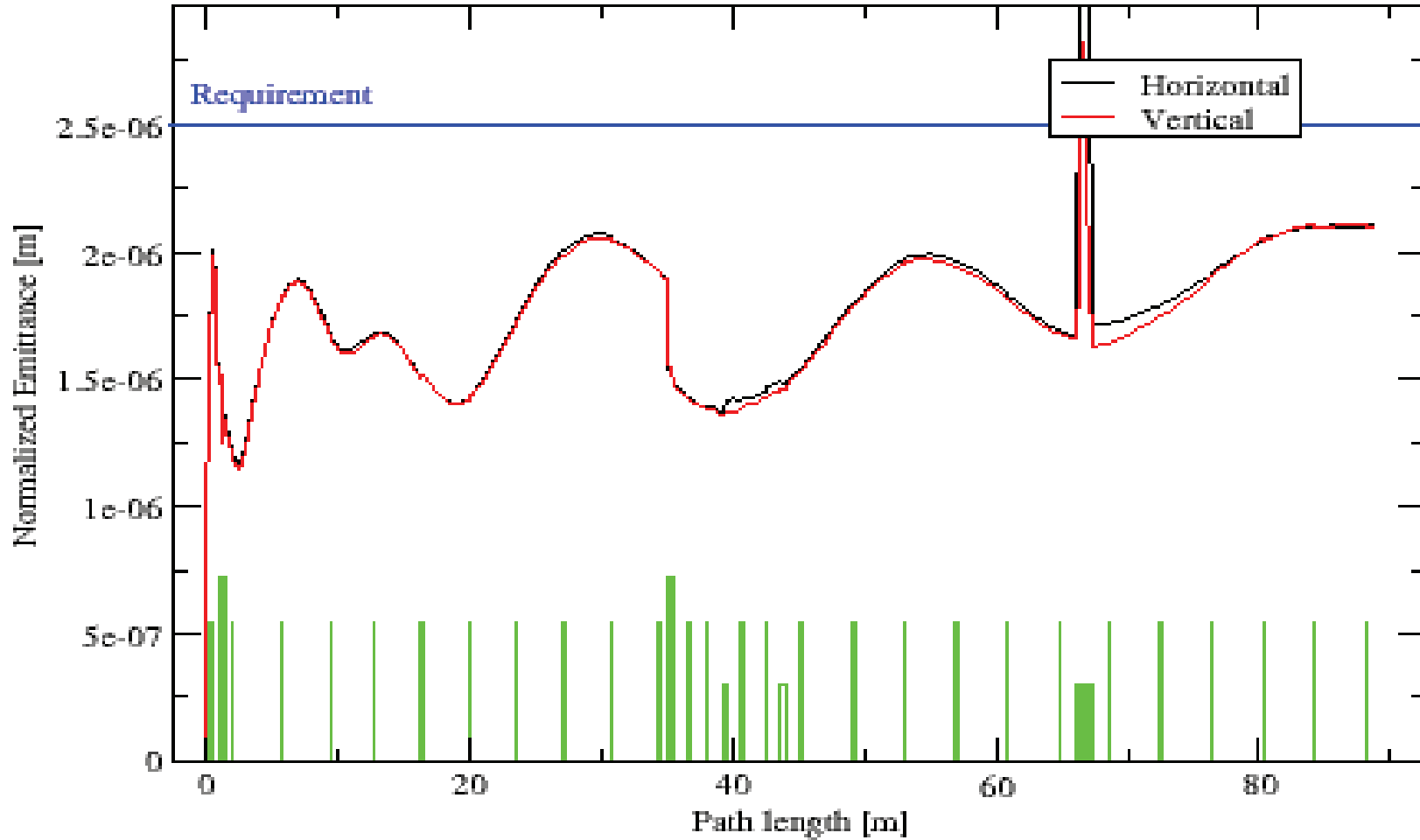

RMS Envelopes

LEReC with DC gun 1.6 MeV

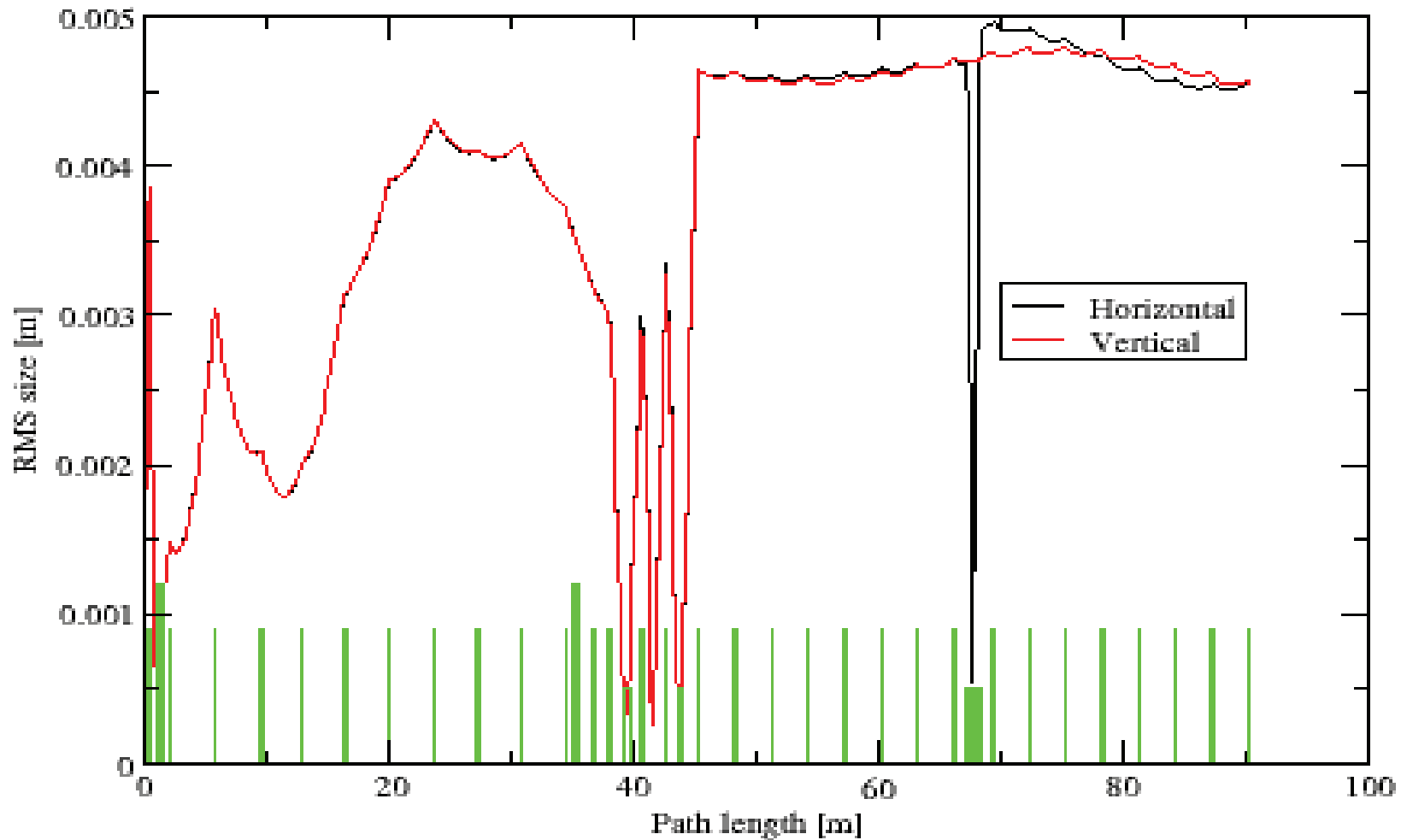

RMS Energy spread

LEReC with DC gun 1.6 MeV

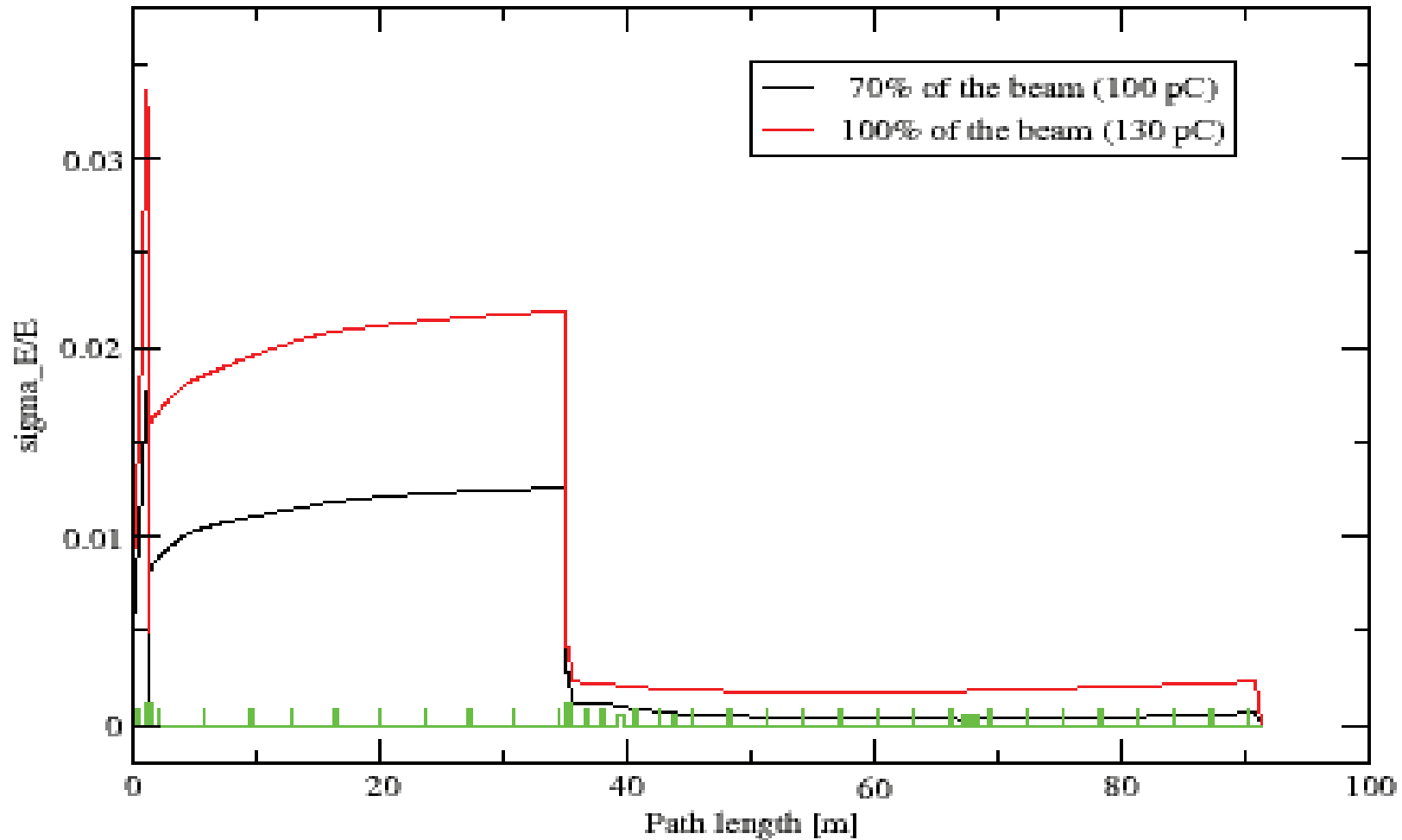

RMS Energy spread

LEReC with DC gun 1.6 MeV

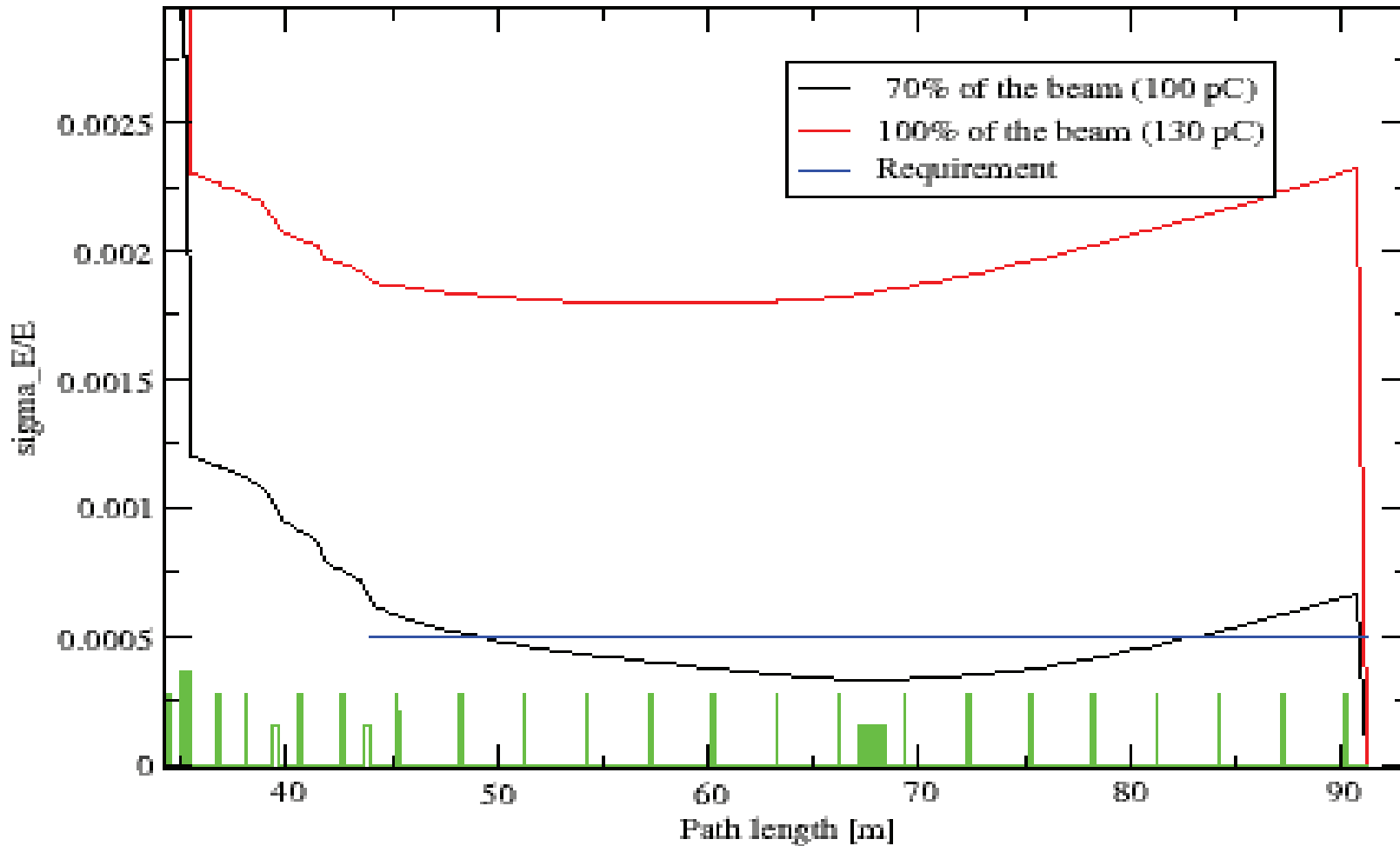

Bunch length

LEReC with DC gun

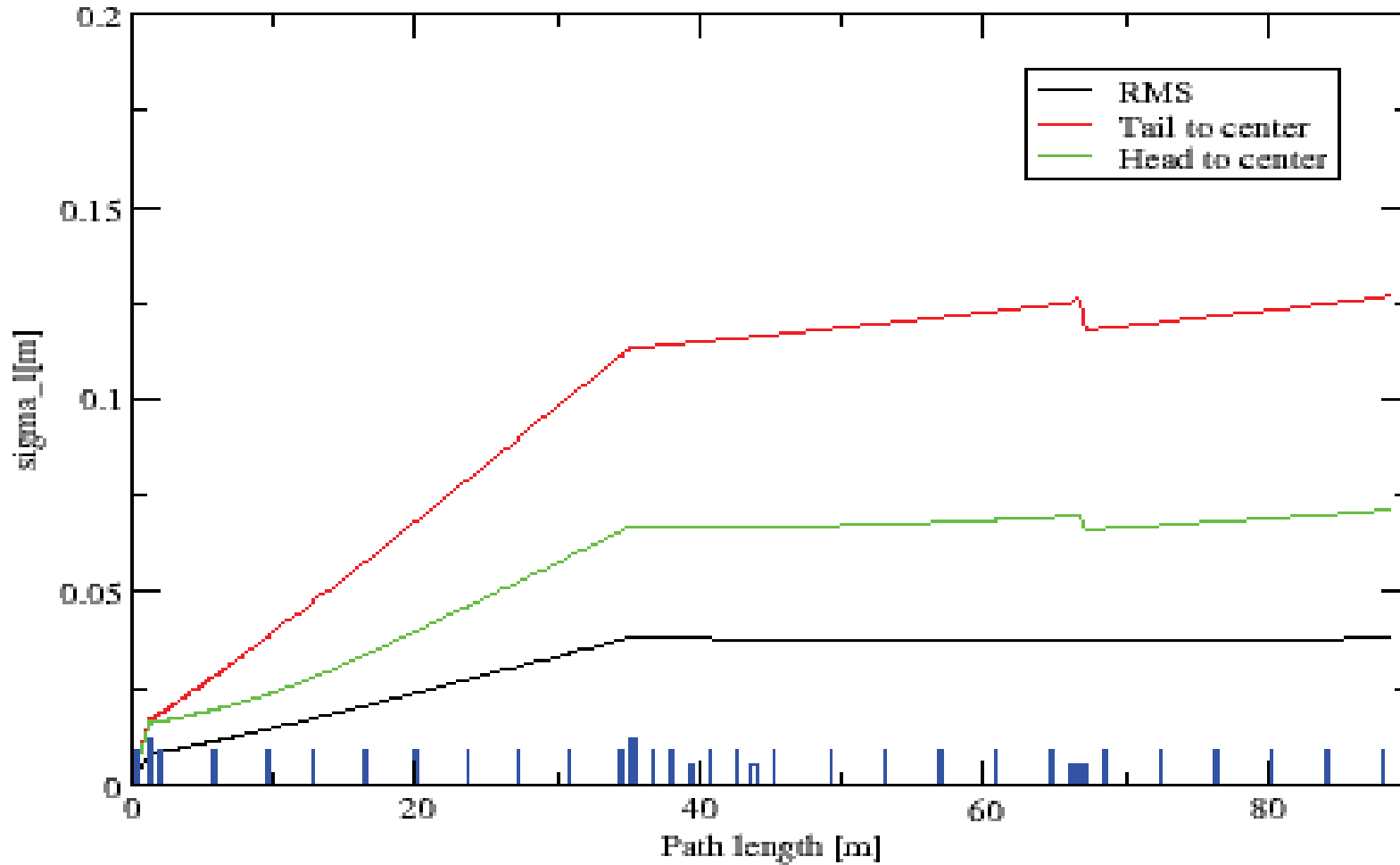

RMS Energy spread

LEReC with DC gun at 2 MeV

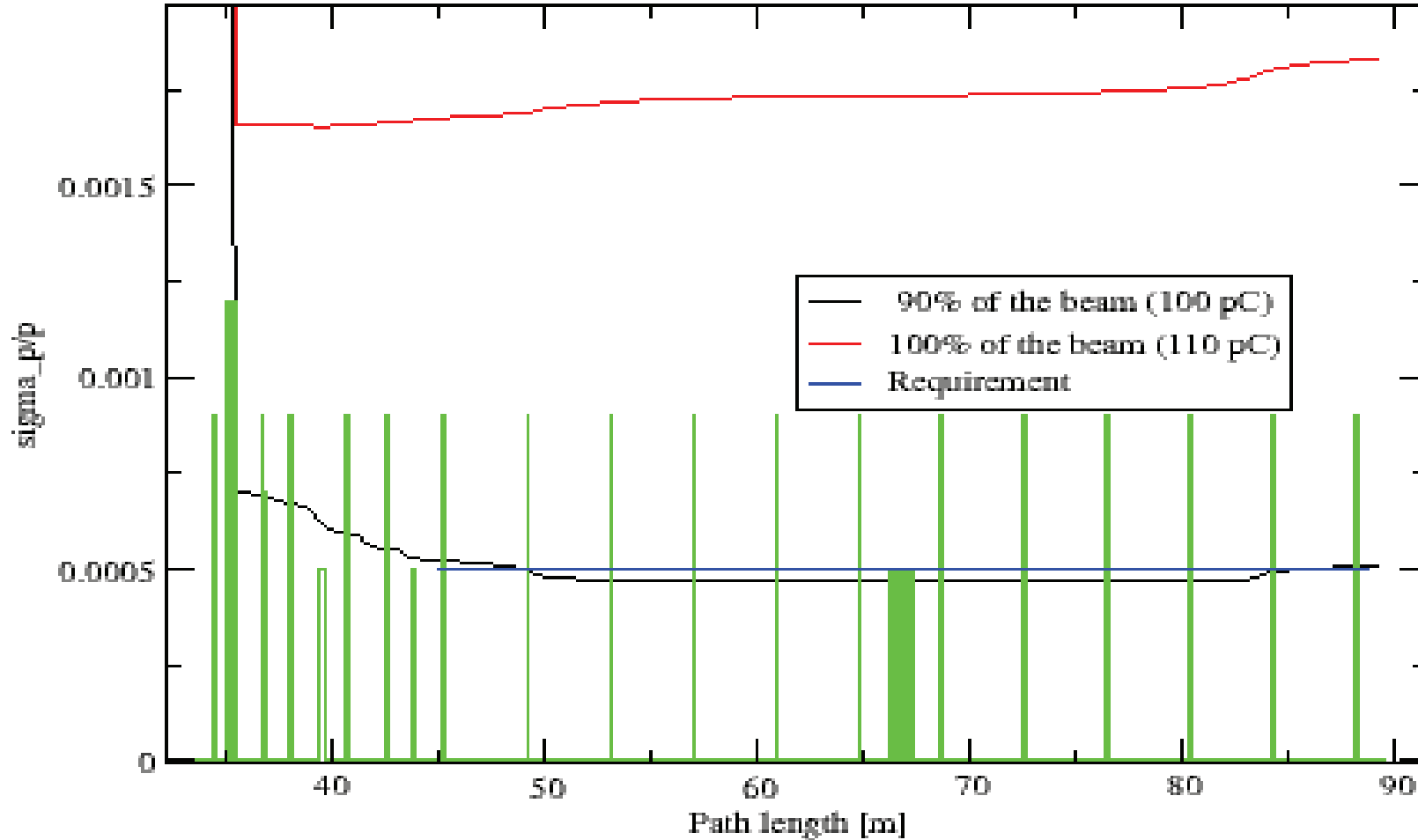

Summary

- Phase I of our project is approved
- Simulations show that the design using the DC gun fulfills the emittance requirement
- Everything is much easier at higher energies
- LEReC would be a prove of principle that electron cooling with bunched beams is possible. This will pave the way for electron cooling at higher energies

