

Current Status of the MESA Project

Robert Heine

on behalf of MESA Accelerator Working Group

- Project overview
- Main accelerator & SRF modules
- Injector MAMBO & LEBT
- Photo source

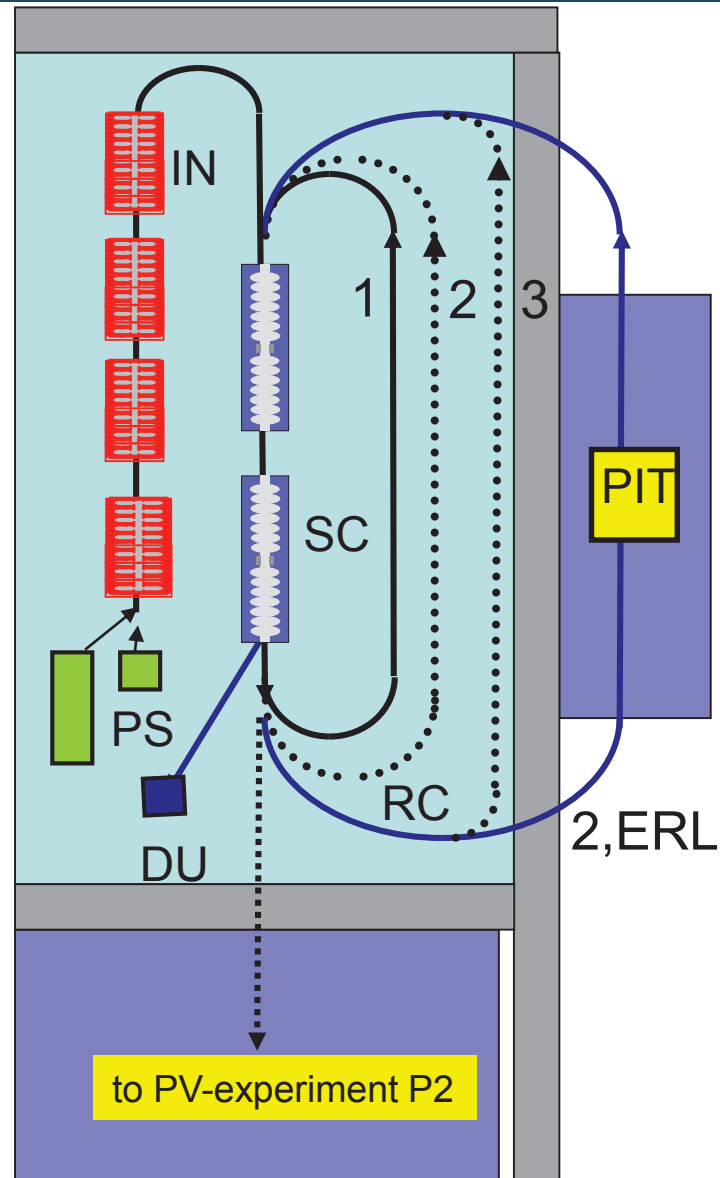

MESA main objectives

1. Precision measurement of the weak mixing angle (P2-experiment)
2. Accelerator physics: Multi-turn, superconducting ERL
3. New experimental technique for nuclear and particle physics: The PIT - high luminosity/low background at low energies

MESA BEAM PARAMETERS (as of today):

CW beam

EB-mode: 150 μ A, 200 155 MeV spin polarized beam (liquid Hydrogen target $L \sim 10^{39}$)

ER-mode: 1 mA (10 mA), 105 MeV unpolarized beam (Pseudo-Internal Hydrogen Gas target, PIT $L \sim 10^{35}$)

SKETCH from 2010 !

SRF-Systems
F. Schlender
T. Stengler (PhD-st.)

Sources & LEBT
K. Aulenbacher
S. Friederich,
V. Bechthold (PhD-st.)

High Power & RT RF
R. Heine
C. Matejcek (PhD-st.)
P. Heil, B. Ledroit (MSc-st.)

Warm Systems
L. Hein
S. Heidrich , I. Alexander (PhD-st)
C. Stoll (MSc-st)

Beam Dynamics
F. Hug (des.)
D. Simon (PhD-st.)

Beam Control & Feedbacks
J. Diefenbach
R. Herbertz (PhD-st)



KPH-Departments

- MAMI (H. J. Kreidel)
- Vacuum and Cryogenics (E. Schilling)
- Electronic workshop (W. Lauth)
- Mechanical workshop (P. Jennewein)
- IT (K.W. Krygier)
- Rad. prot. (J. Diefenbach)
- Installation (A. Thomas)
- Tech-Design (K. Aulenbacher)

- Lattice was modelled with:
 - in house matrix optics program
 - MAD X
 - PARMELA for space charge and pseudo damping due to main linac modules

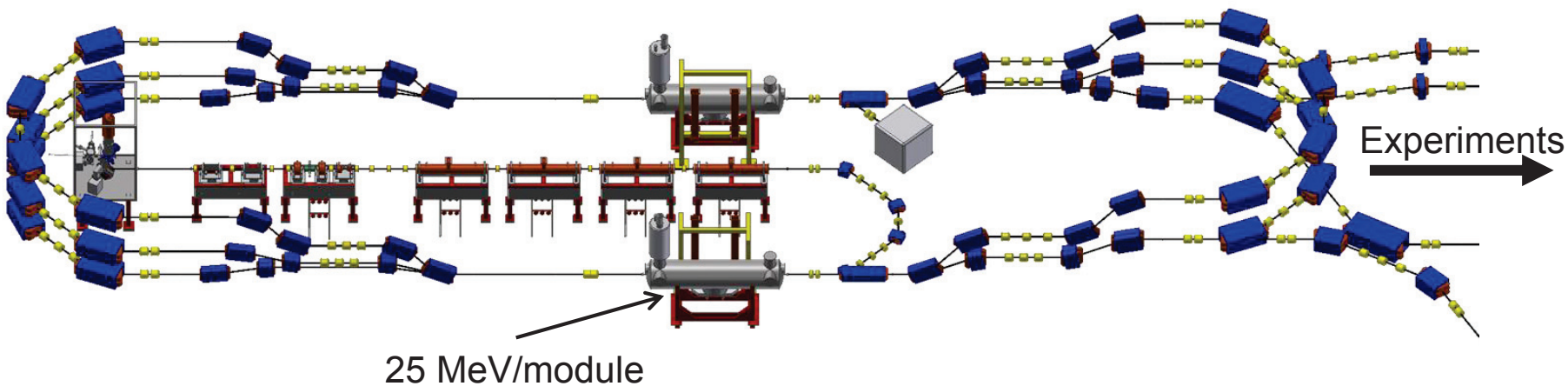
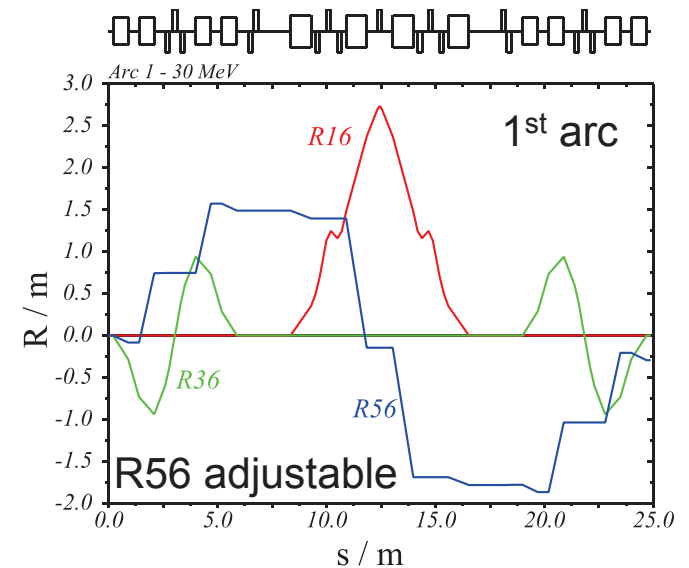

D. Simon presented at IPAC15, MOPWA046

Beta functions from PARMELA for MESA in ERL mode

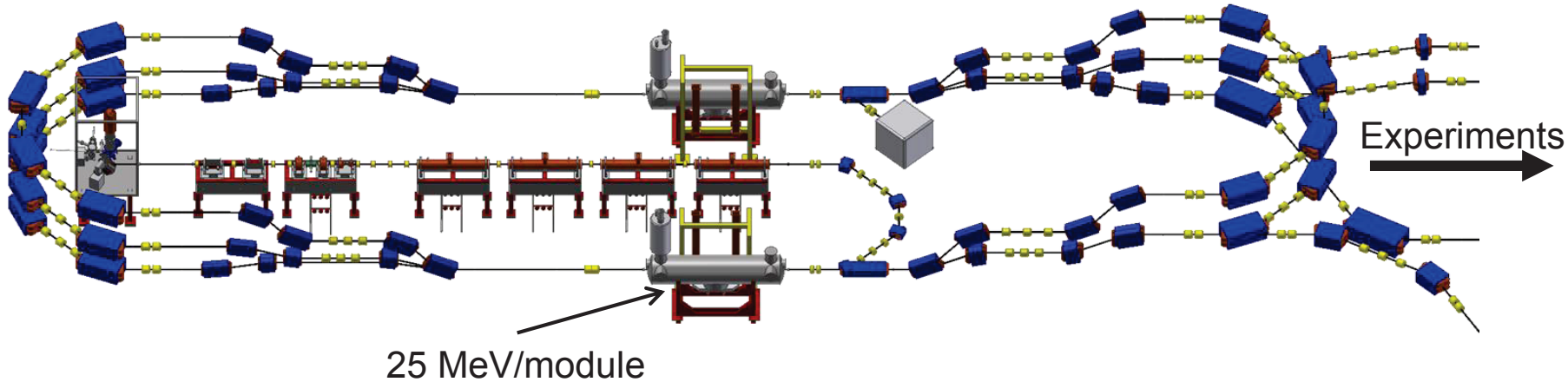
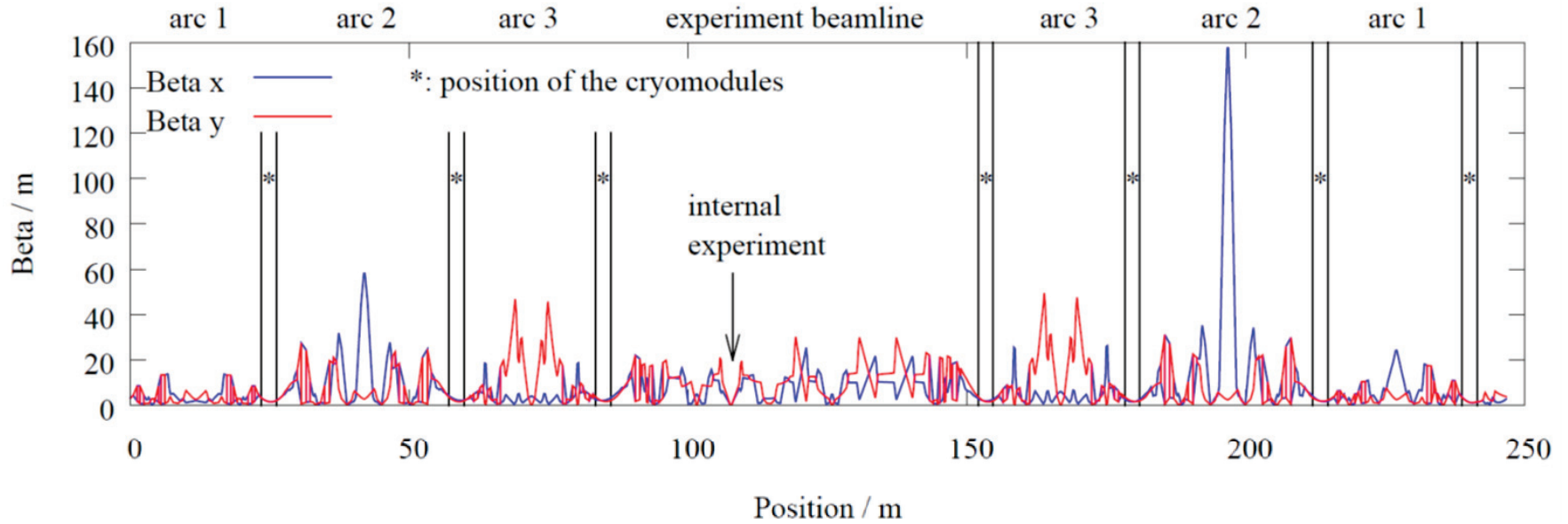

D. Simon presented at IPAC15, MOPWA046

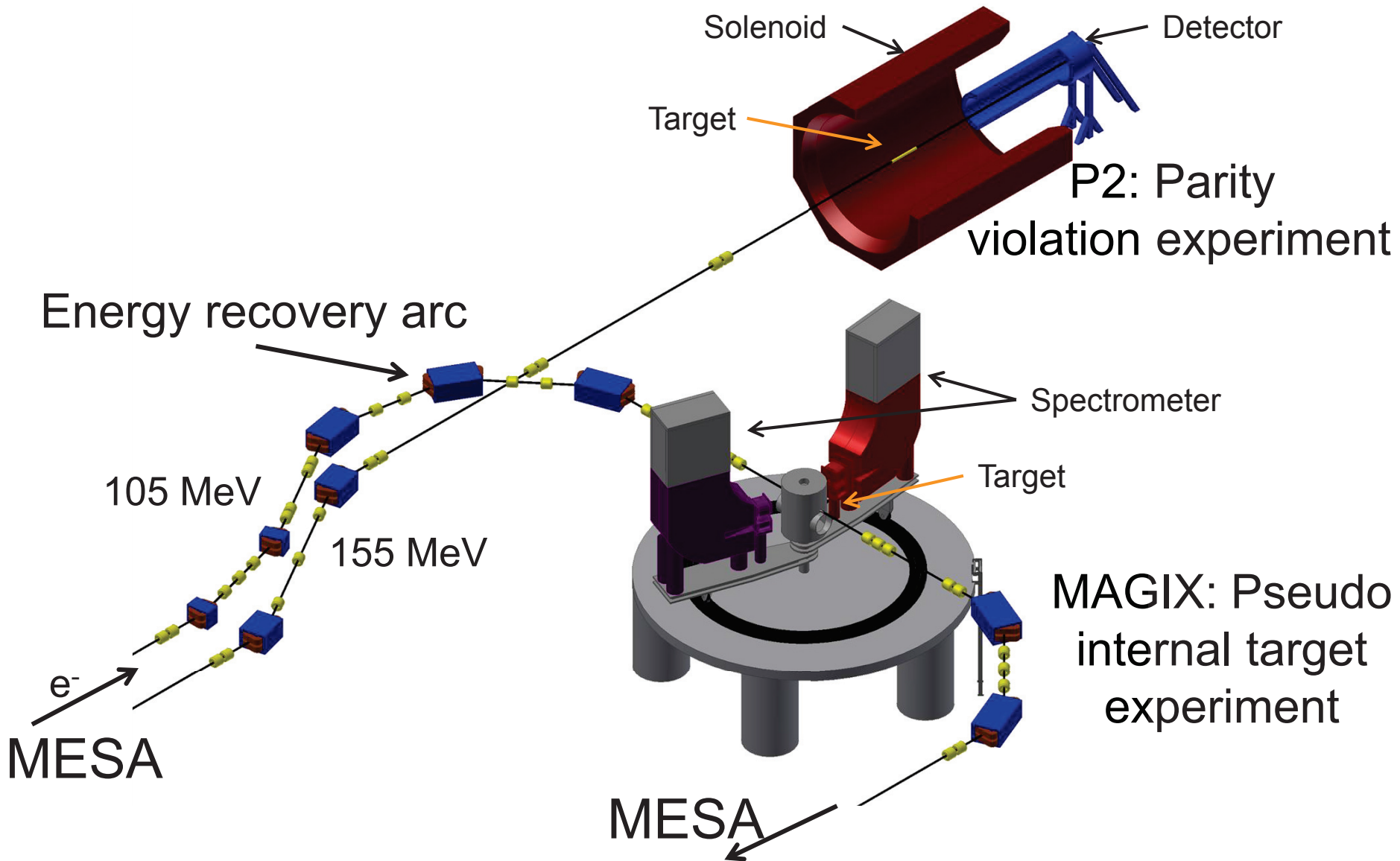

- Order has been placed in March 2014 at Research Instruments
- Two ELBE Rossendorf Modules with some modifications (turn key):
 - XFEL Tuner (Piezo) → reconstruction of He-tank
 - XFEL HOM Damper with sapphire feed through (CW!)
- Additional 4K/2K cold box and controls developed by RI (consulted by DESY)

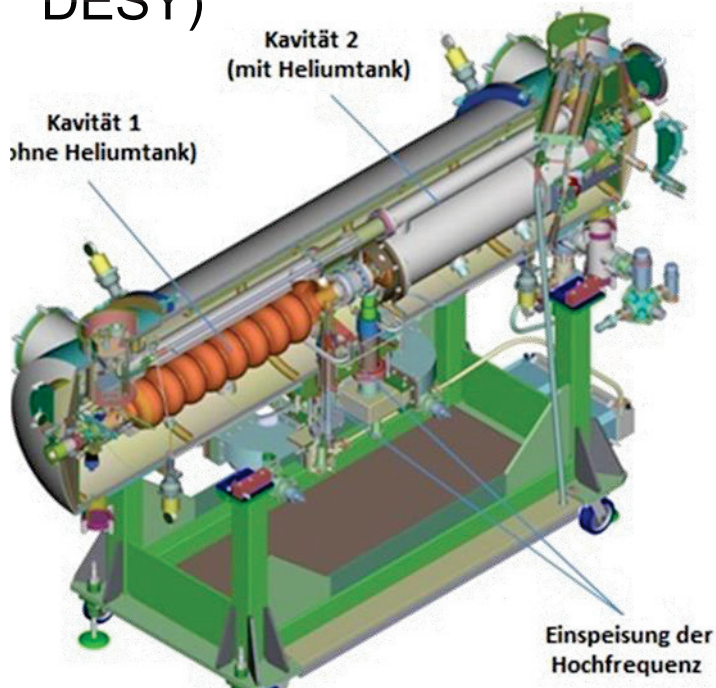

J. Teichert et al. NIMA 557 (2006) 239

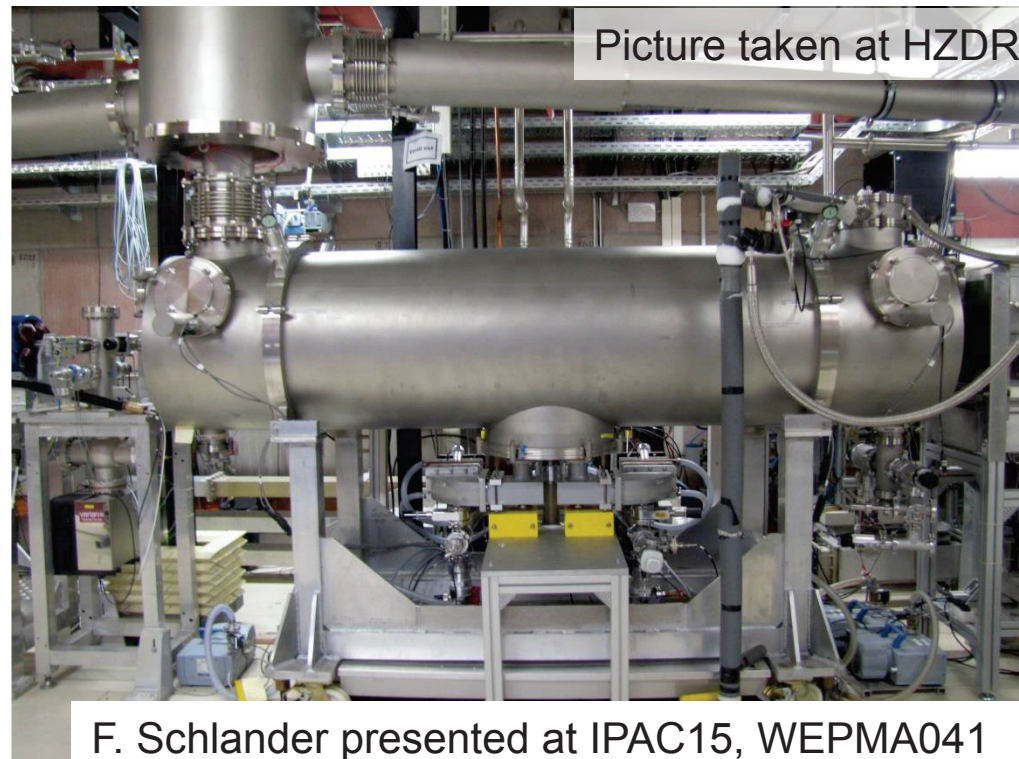

F. Schlander presented at IPAC15, WEPMA041

- Inspired by the MAMI injector LINAC
- 4 room temperature RF bi-periodic $\pi/2$ standing wave structures @ 1.3 GHz
- 1 graded- β , 3 const. β sections
- Energy gain $\Delta E = 1.25$ MeV/section
- Beam dynamics with PARMELA 3D
- RF and thermal design with CST Studio Suite

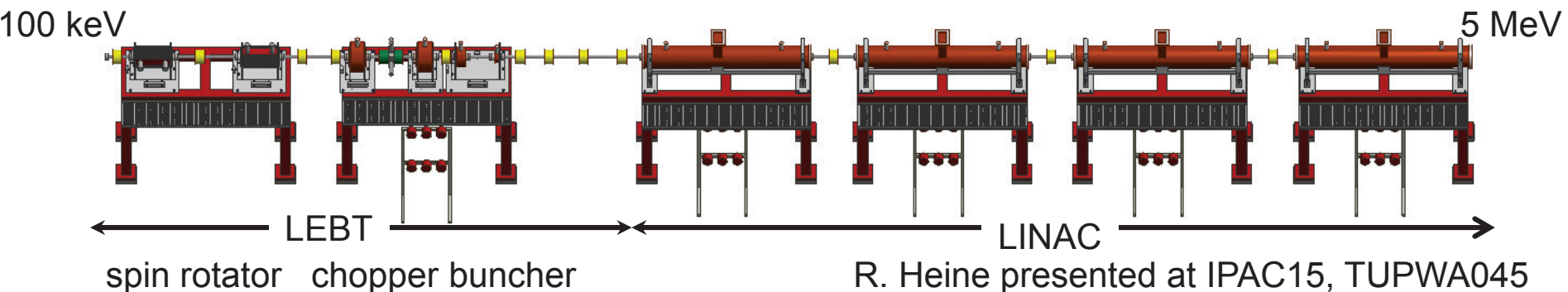

e.g. Section 1

graded- β ,
 $\beta = 0.548 \dots 0.957$

$R_s = 49.7 \text{ MOhm}$
 $Q_0 = 21500$
 $L = 1658 \text{ mm}$

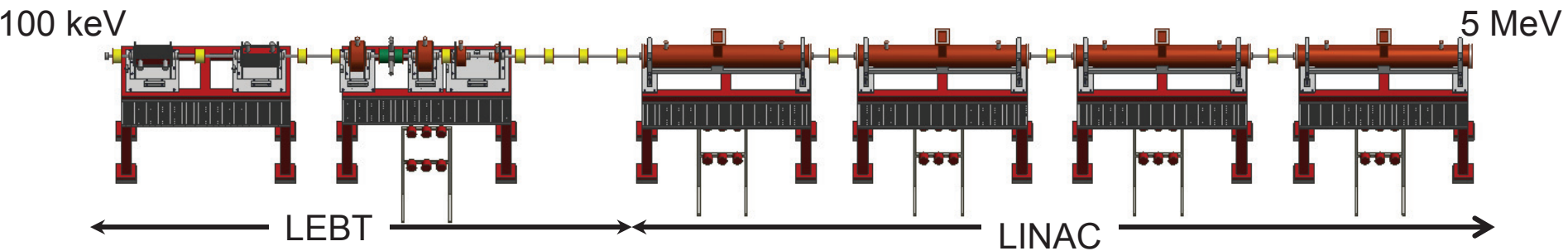
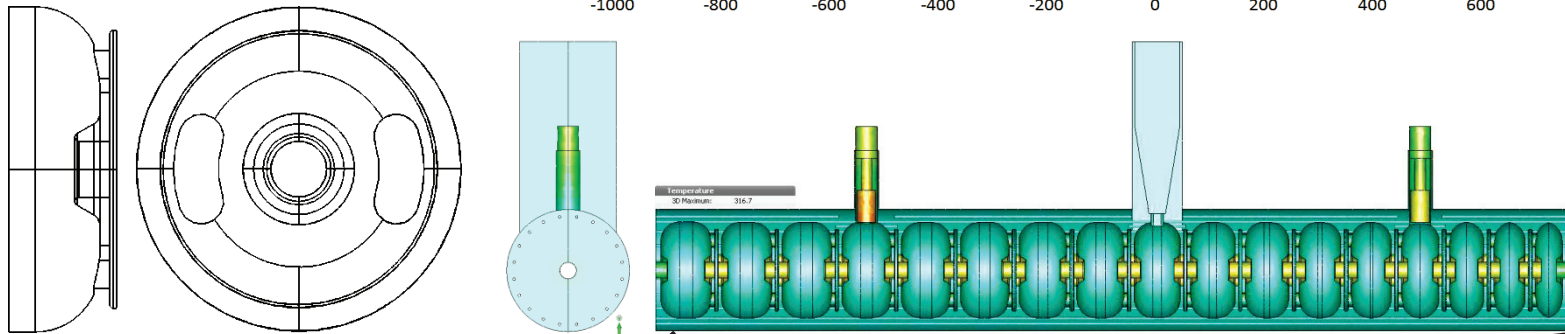
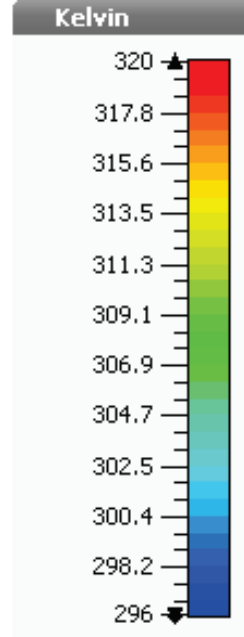
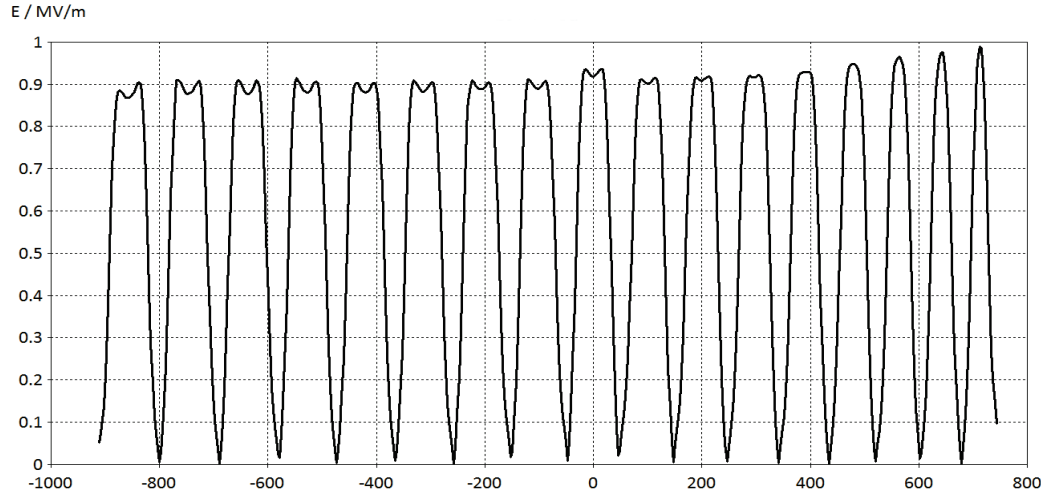

R. Heine presented at IPAC15, TUPWA045

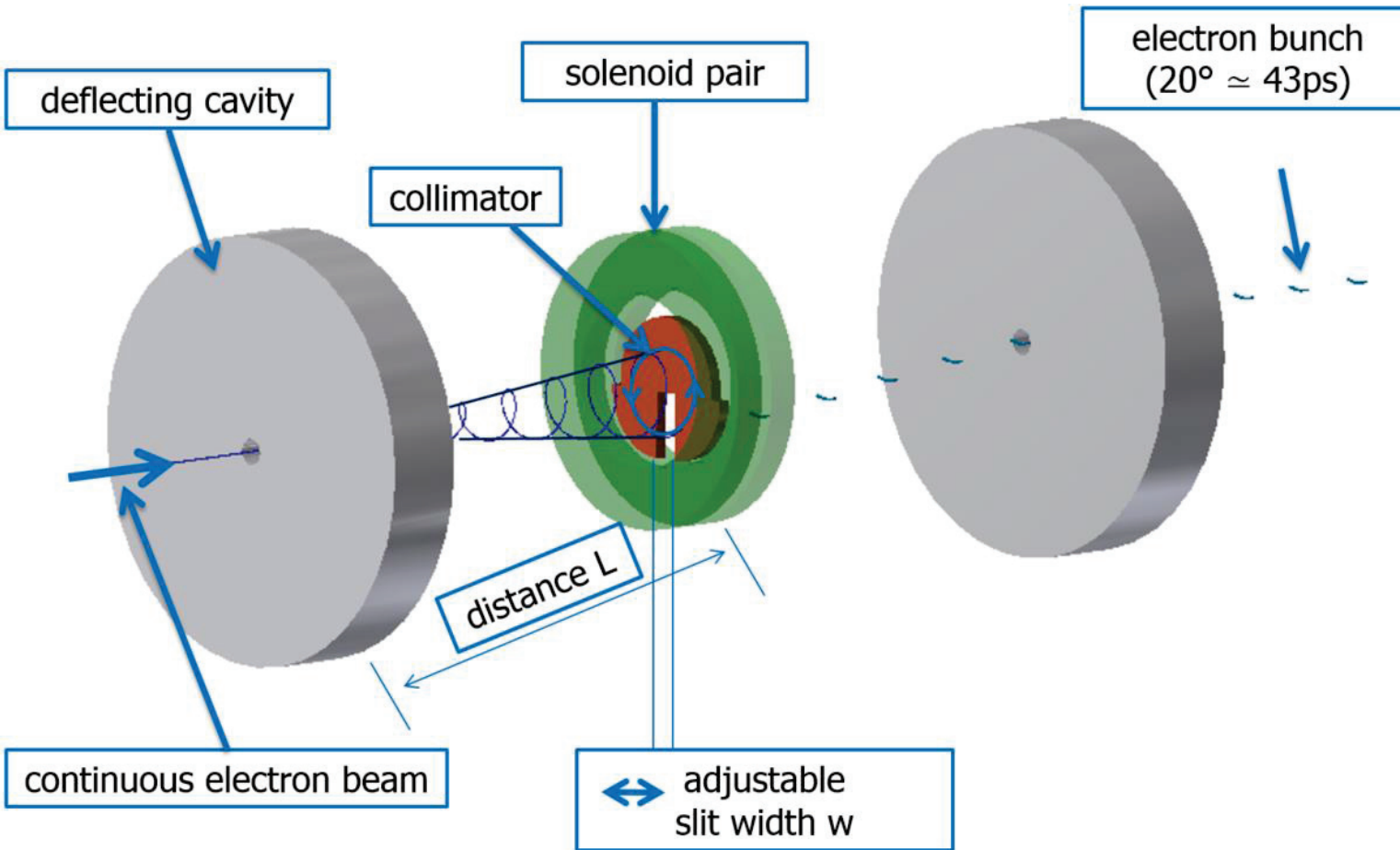

Deflector: Diploma thesis V. Bechthold

Collimator: Master's thesis B. Ledroit (in preparation)

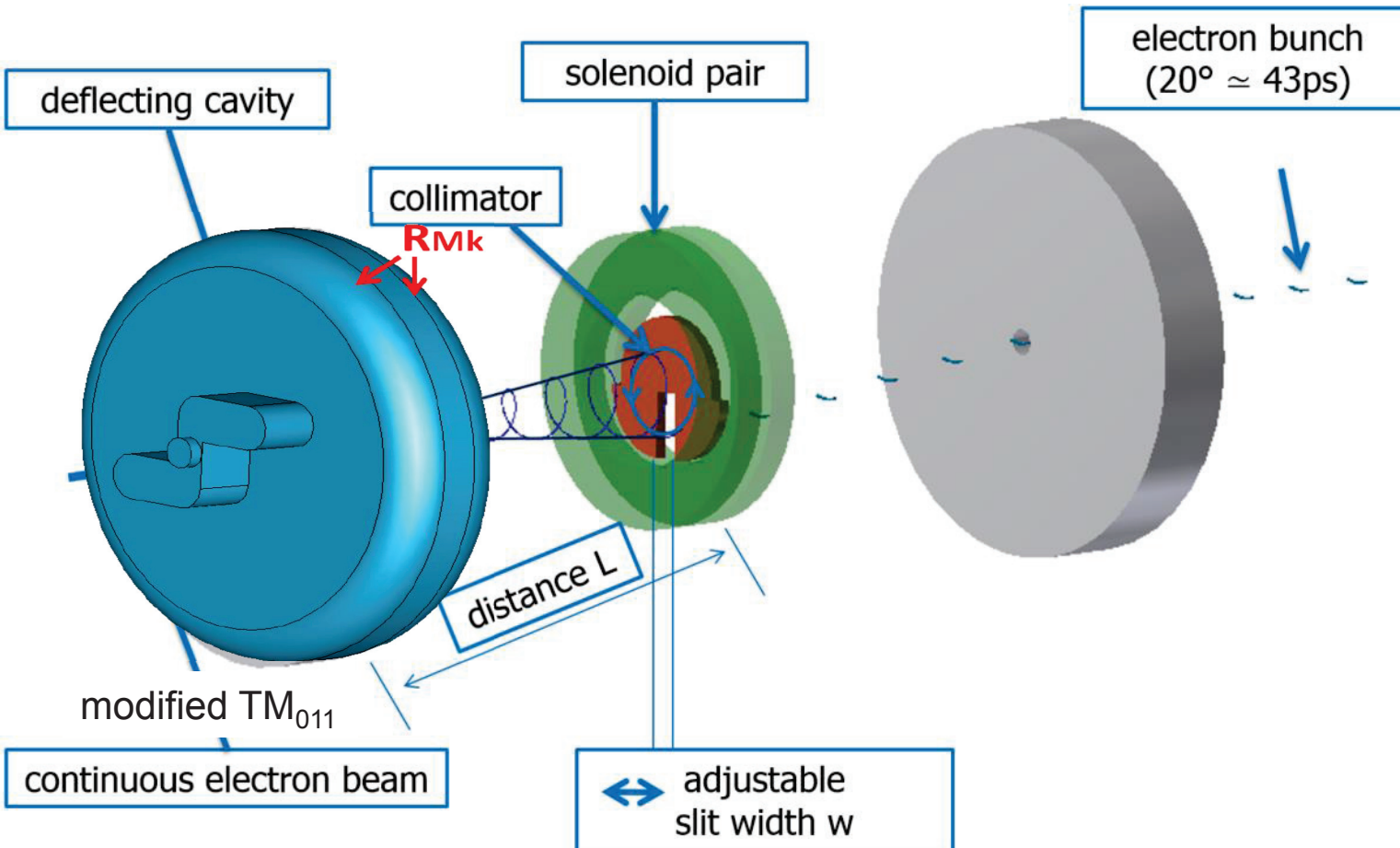

Deflector: Diploma thesis V. Bechthold

Collimator: Master's thesis B. Ledroit (in preparation)

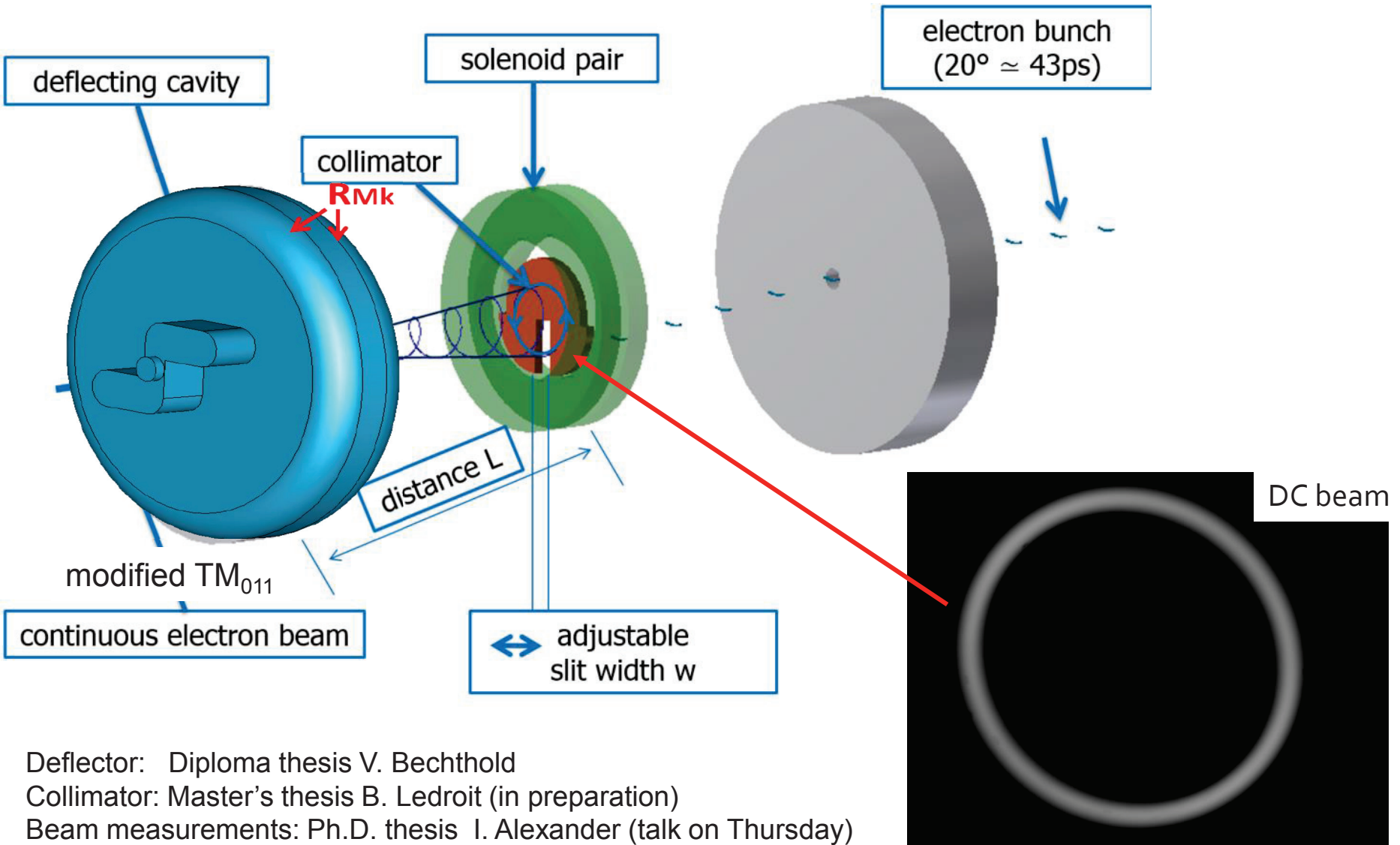

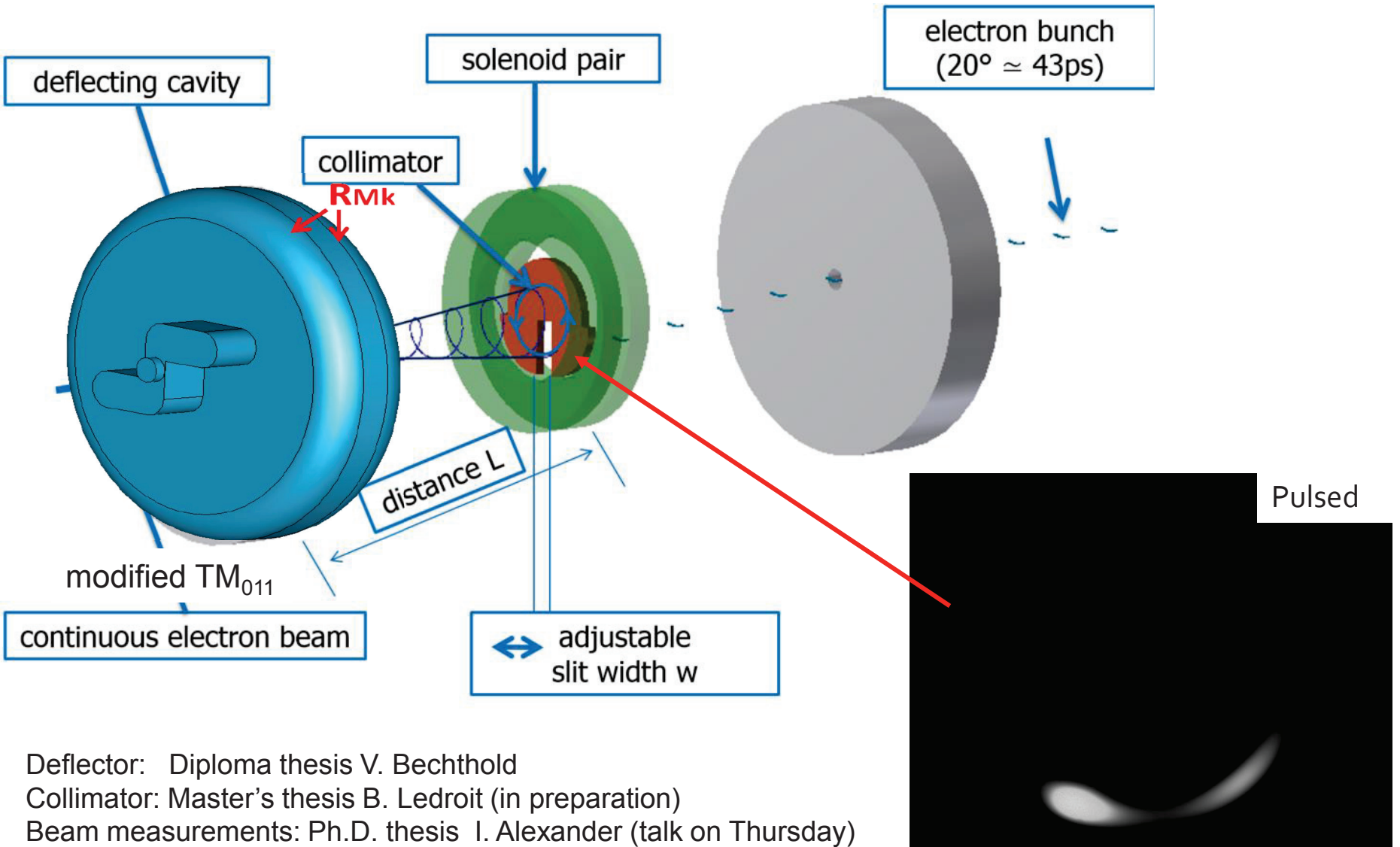

1.3 GHz deflecting cavity first working RF component for MESA

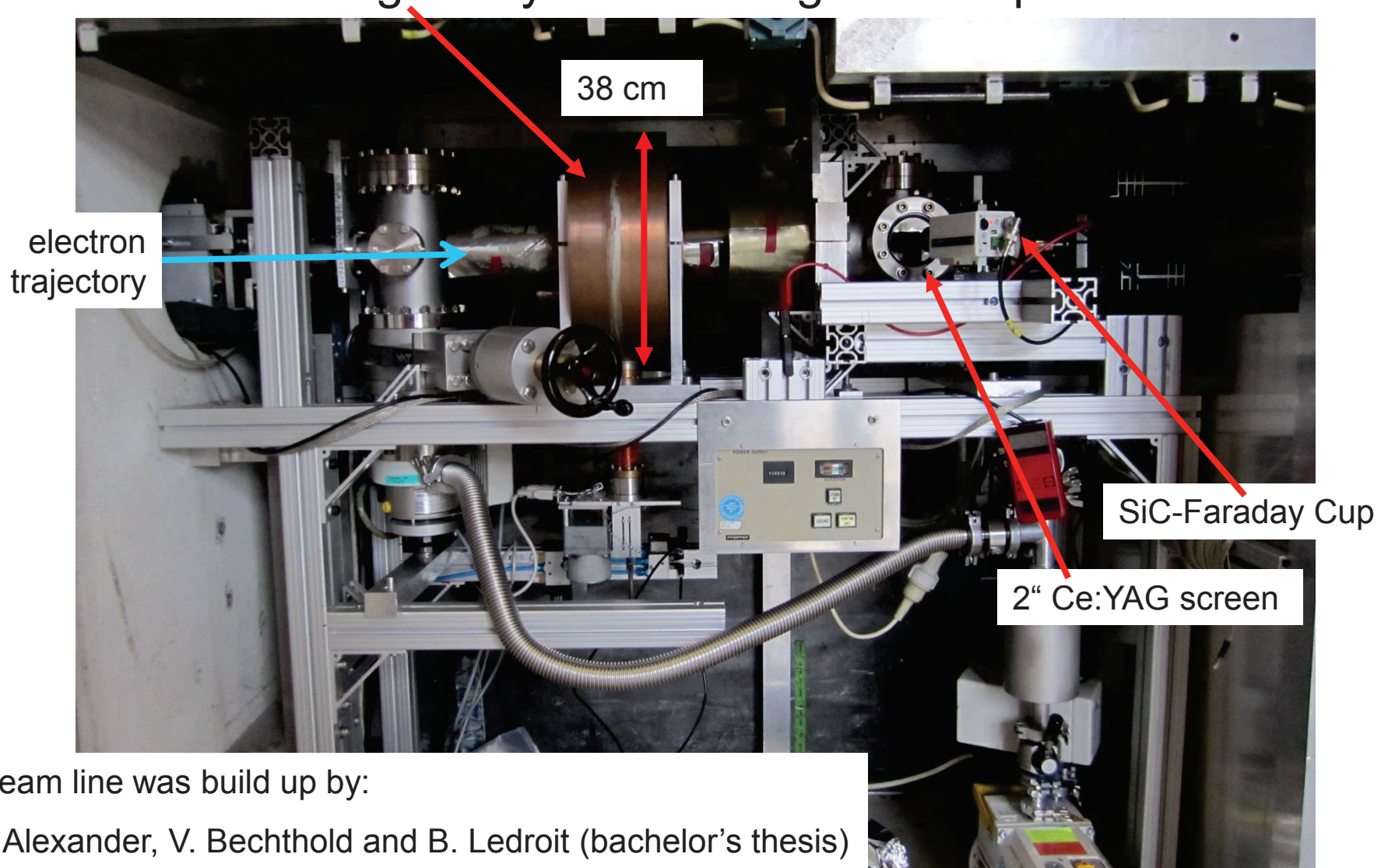

- f_{RF} and $2f_{RF}$ buncher cavity
- Provide more linear modulation of velocity
- Capturing process in first linac section is more efficient

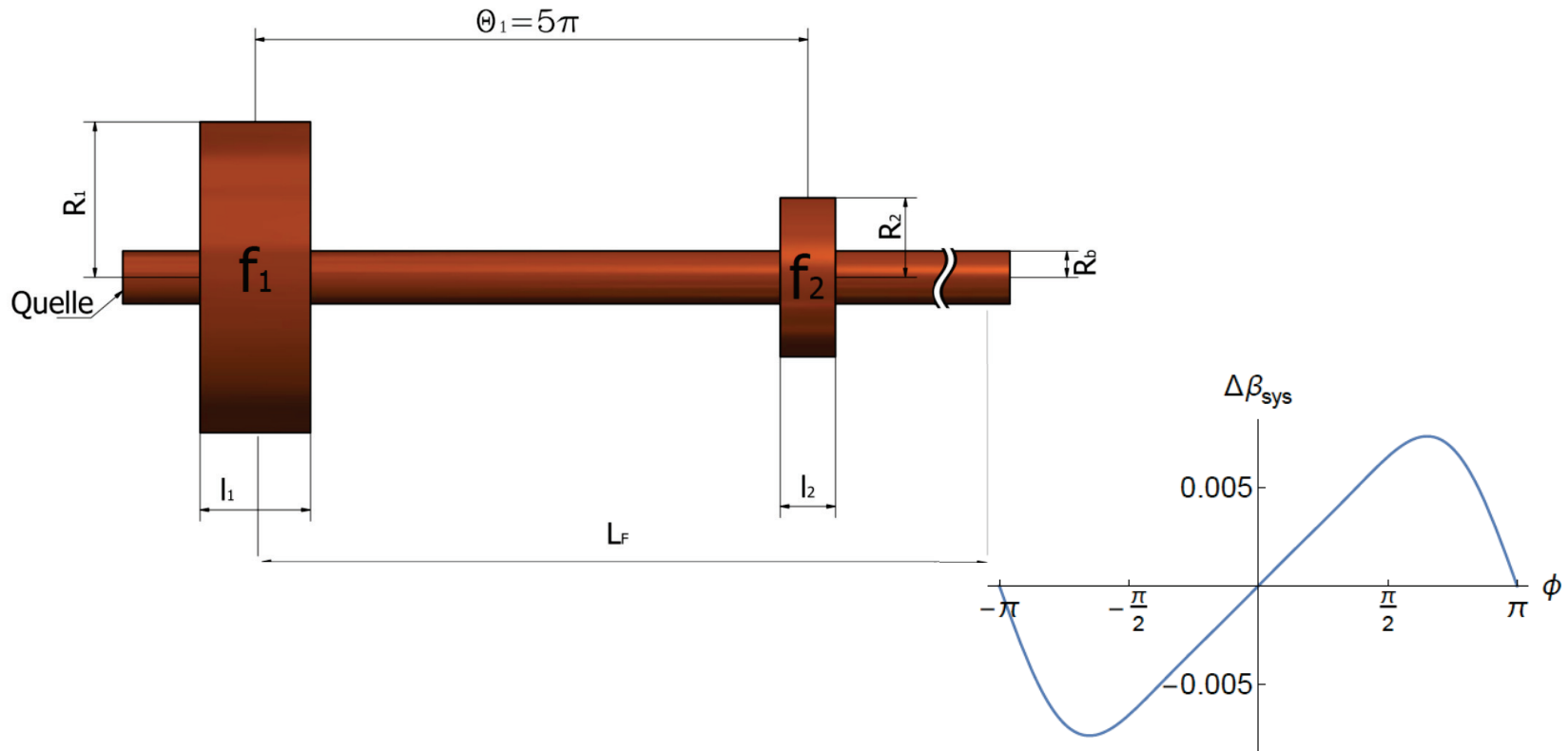

Master's thesis P. Heil (in preparation)

(c) $\alpha_1 = 0,01199$, $\alpha_2 = 0,0034$

- f_{RF} and $2f_{RF}$ buncher cavity
- Provide more linear modulation of velocity
- Capturing process in first linac section is more efficient
- f_{RF} Al-prototype finished,
- f_{RF} Cu-cavity and $2 f_{RF}$ Al-prototype in production

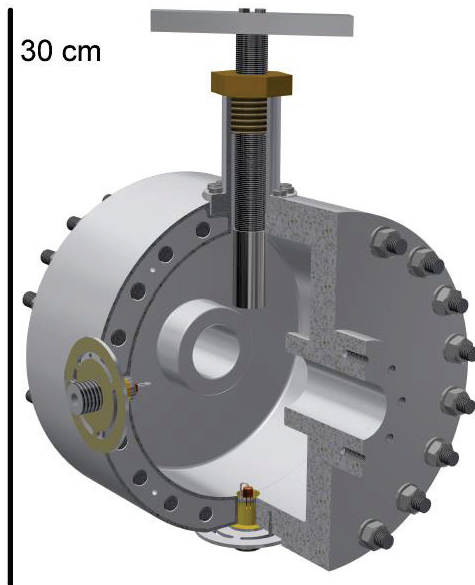

Master's thesis P. Heil (in preparation)

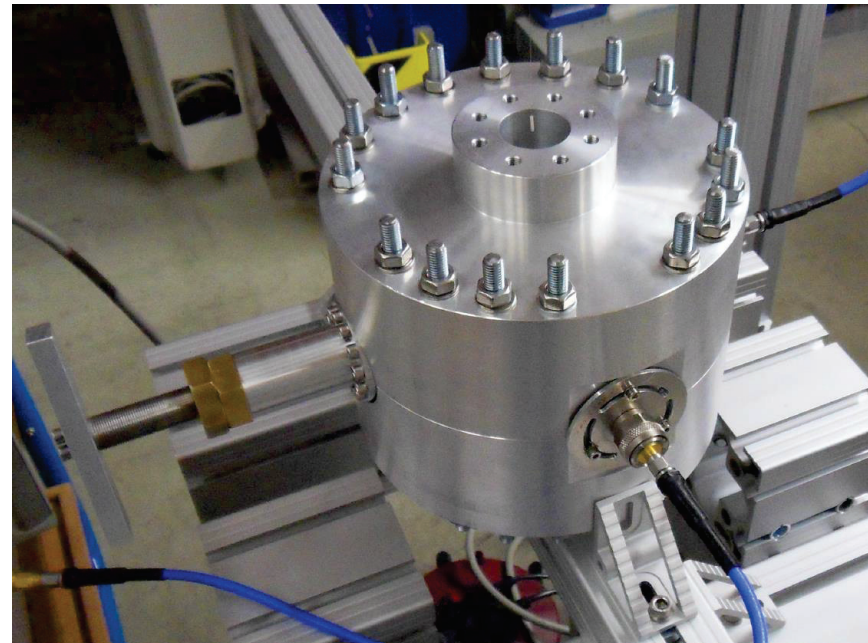

f_{RF} Al-prototype on bead pull station

- Existing photo source PKA2 used as test bed
- Copy of MAMI source
- 100 keV

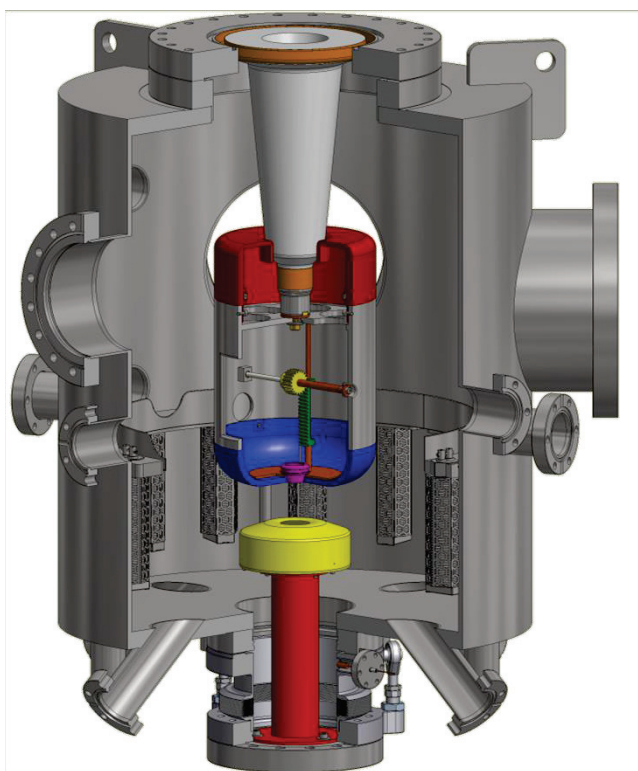
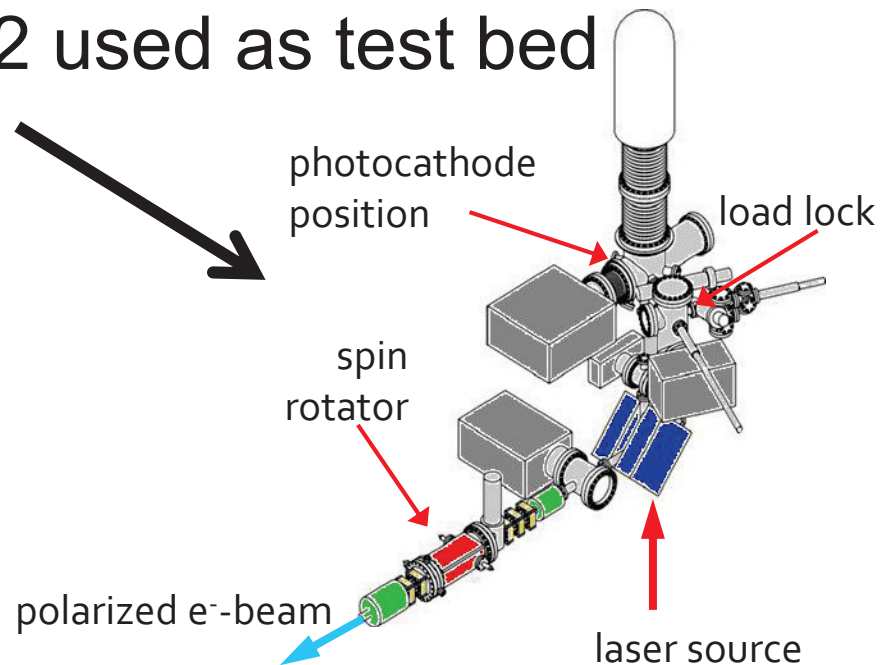

- Upgrade Program STEAM
- New designed inverse cathode (→ JLAB)
- 100-200 keV

S. Friederich presented at IPAC15, TUPWA044

- The MESA Project is well on the way
- Particle source and LEBT will be available in 2016
- MAMBO RF & thermal design is finished
- SRF modules shall be delivered in Apr./Jun 2017

- But still a lot to be done:
 - MAMBO prototyping and tendering
 - Tendering of SSA RF amplifiers
 - Design of 5 MeV beam line
 - Design of main accelerator magnets (starting in Aug.)
 - Reconstruction of our caves (planning started in 2014)