



# Operation Mode of AIC-144 Multipurpose Isochronous Cyclotron for Eye Melanoma Treatment

K. Daniel, K. Gugula, J. Sulikowski, IFJ-PAN, Krakow,  
Poland

I. Amirkhanov, G. Karamysheva, I. Kiyan, N. Morozov,  
E. Samsonov, JINR, Dubna, Russia.

# INTRODUCTION

- The AIC-144 cyclotron is used at the Institute of Nuclear Physics, Polish Academy of Sciences, mainly as a source of deuteron and proton beams for isotope production on the internal target.
- In the past years several systems of the cyclotron have been modified in order to provide parameters of the external proton beam with an energy of 60 MeV necessary for eye melanoma radiotherapy which has been conducted at the INP since 2011

# AIC-144 cyclotron (IFJ, Krakow)



CYCLOTRONS 2013

# Magnet system AIC-144 cyclotron.



# Magnet system AIC-144 cyclotron.

There are three types of coils in the AIC144:

- The main coil for exciting the main magnet that generates the main magnetic field  $B_{main}(r, \theta)$ .
- Twenty trim coils concentrically inserted into one another which generate the resulting magnetic field  $B_{res}(r, \theta)$  as a sum of the main magnetic field  $B_{main}(r, \theta)$  and the contributions from the 20 trim coils  $B_{add, i}(r, \theta)$ ,  $i = 1-20$ .
- Two pairs of harmonic coils intended for correcting the first harmonic of the resulting magnetic field  $B_{res}(r, \theta)$  affected by the imperfection of the assembly of the magnetic system and vacuum chamber mounting.

# Trim and harmonic coils

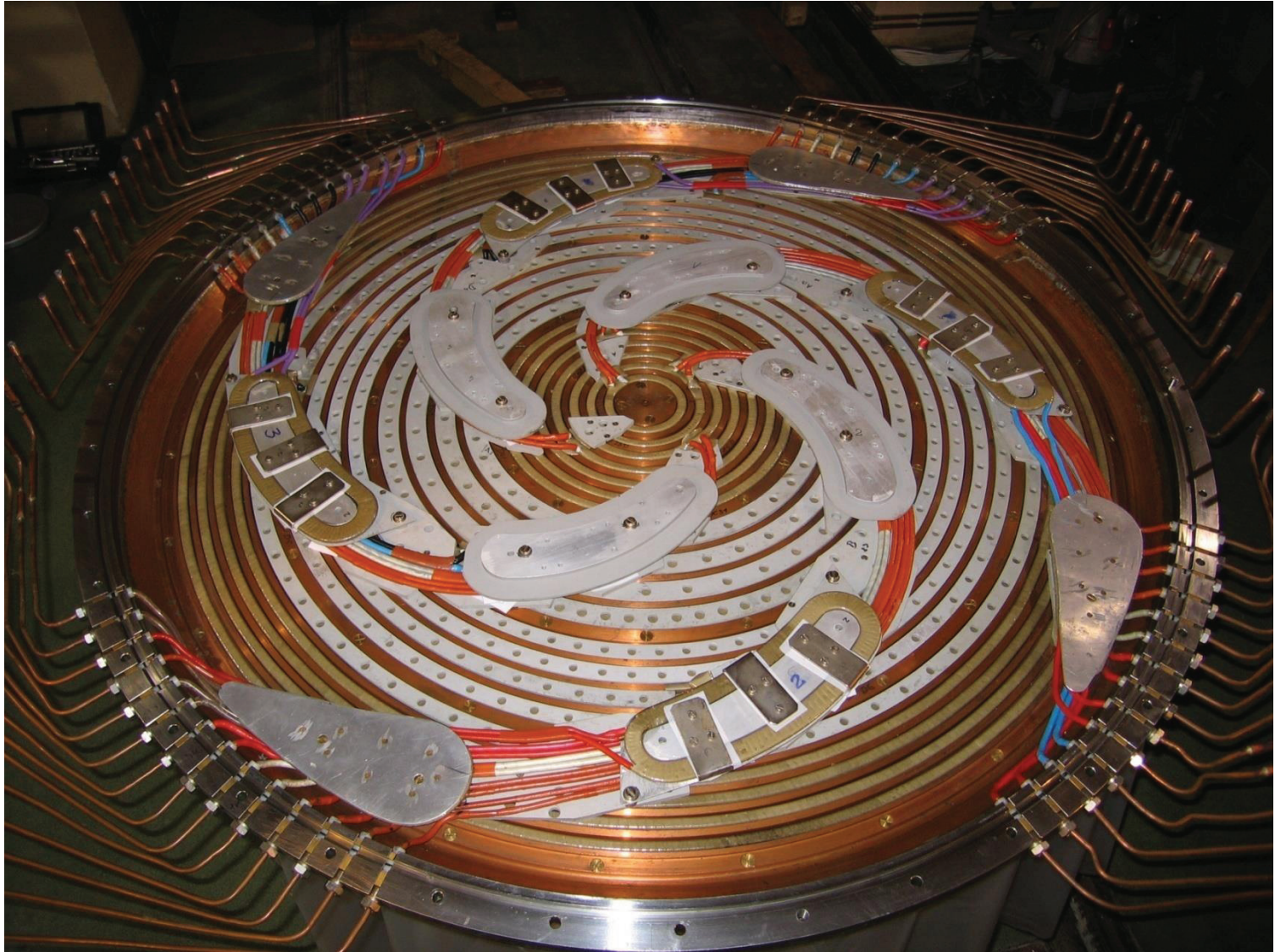

CYCLOTRONS 2013

# Main parameters of the AIC–14 cyclotron

Weight, t	140
Magnet pole diameter, cm	144
Magnetic structure	4 sectors with spiraling angles of 45 to 54°
Magnetic field, T	0,85 ÷ 1,8
Main coil current, A	0 ÷ 650
Number of trim coils	20
Number of harmonic coils	4
Number of dees	1 ( $\alpha = 180^\circ$ )
RF generator frequency, MHz	10 ÷ 27
Voltage at dees, kV	< 65
System of ion beam extraction	electrostatic deflector, two passive and one active magnetic channels
Ion source	Internal PIG

# AIC-144

Particles	A/Z	Energy
Protons	1	30 ~ 60 MeV
Deuterons	2	15 ~ 30 MeV
$\alpha$ -particles	2	30 ~ 60 MeV

Isotope	Nuclear reaction
$^{11}\text{C}$	$^{11}\text{B}(\text{p}, \text{n})^{11}\text{C}$
$^{204}\text{Bi}$	$^{206}\text{Pb}(\text{p}, 3\text{n})^{204}\text{Bi}$
$^{211}\text{At}$	$^{209}\text{Bi}(\alpha, 2\text{n})^{211}\text{At}$
$^{48}\text{V}$	$^{\text{nat}}\text{Ti}(\text{p}, \text{xn})^{48}\text{V}$
$^{56}\text{Co}$	$^{58}\text{Ni}(\text{p}, \text{n}2\text{p})^{56}\text{Co}$
$^{99}\text{Rh}$	$^{\text{n}}\text{Ru}(\text{p}, \text{xn})^{99-102}\text{Rh}$
$^{111}\text{In}$	$^{109}\text{Ag}(\alpha, 2\text{n})^{111}\text{In}$
$^{173}\text{Hf}$	$^{\text{n}}\text{Yb}(\alpha, \text{xn})^{173}\text{Hf}$
$^{178}\text{W}$	$^{\text{n}}\text{Ta}(\text{p}, \text{xn})^{178}\text{W}$
$^{207}\text{Po}$	$^{209}\text{Bi}(\text{p}, 3\text{n})^{207}\text{Po}$



# Diagram of betatron frequencies for the AIC-144 cyclotron.

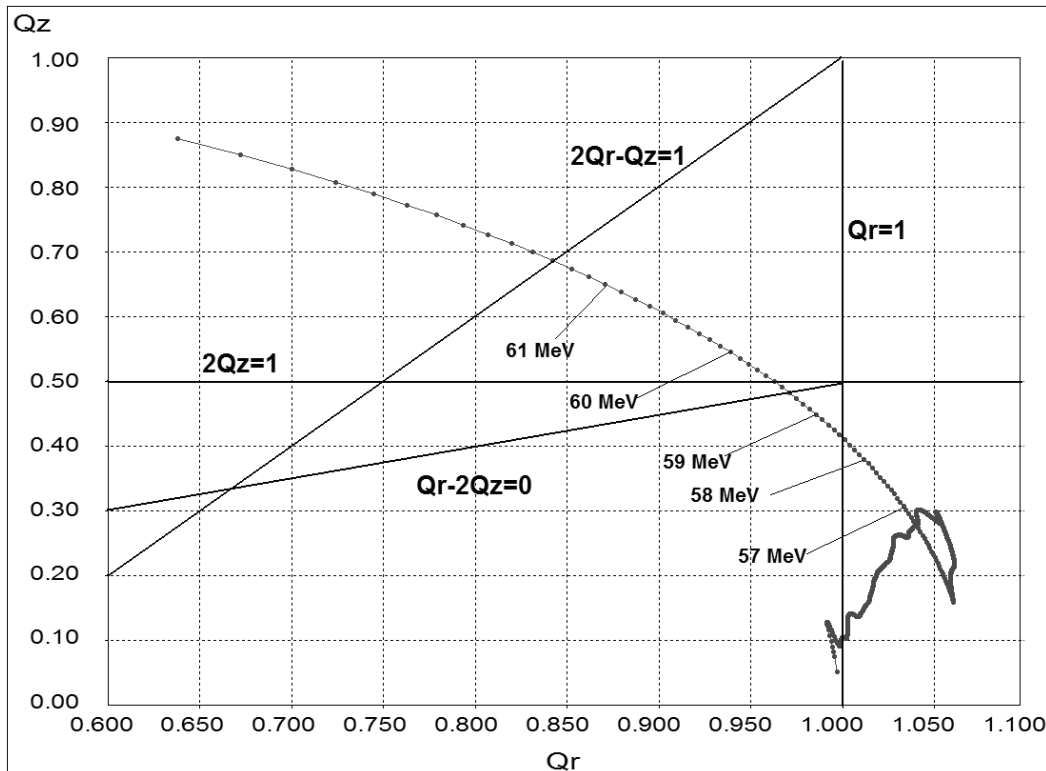

The most important resonance is the nonlinear coupling resonance  $Q_r - 2Q_z = 0$  having the average magnetic field as its driving term. It occurs at an energy of 59.5 MeV and, as a rule, leads to large axial losses of the beam. Another important resonance  $2Q_z = 1$  is crossed just after the coupling resonance. It also increases the axial amplitudes of particles if the radial gradient of the 1st harmonic amplitude is too large.

# 1. IMPROVEMENT OF RF SYSTEM OPERATION

# 2. LATEST SHAPING OF MAGNETIC FIELD

*Verification of the Magnetic Field*

*Shaping of the New Cyclotron Regime*

*Correction of the 1st Harmonic  
of the Magnetic Field*

# IMPROVEMENT OF RF SYSTEM OPERATION

The high-frequency system was revamped. The modernization included reduction of the contact resistance at the power stage of the generator, the acceleration chamber, the resonator, and the chamber connecting the resonator with the acceleration chamber.

Reduction of the contact resistance for high-frequency current resulted in a 50% decrease in power loss and an increase in the amplitude of the high-frequency voltage at the accelerating electrode from ~50 kV to 65 kV.

# Verification of the Magnetic Field

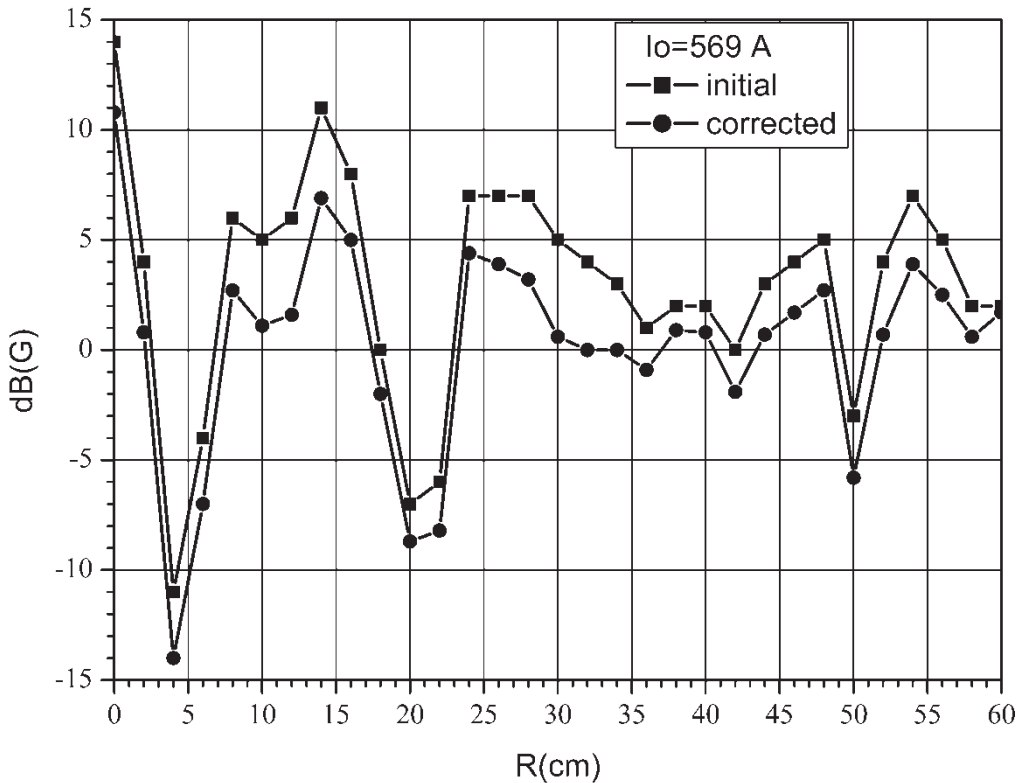

A small ( $\sim 5$  Gs) change was observed in the average magnetic field against the previous (2006) one at the same conditions of the magnet. This difference was corrected by a small change,  $\sim (5-10)$  A, in the excitation current in the cyclotron trim coils.

Deviation of the average magnetic field from the required one

## ***Main regime: $p$ , $F_{rf} = 26,26$ (MHz), $E_k \sim 60,5$ (MeV)***

The  $f=26.26$  MHz,  $I_0=591.5$  A regime was simulated on the basis of a new technique with the aim of increasing the energy of extracted protons and accordingly the penetrability of the beam in the eye therapy room.

The accurate calculations performed using the Cyclotron Operator HELP software made it possible to obtain the main operation mode of AIC144 without any additional magnetic measurements requiring the shutdown and disassembly of the cyclotron what leading to loss of valuable time. This mode was successfully implemented in 2009 without empirical adjustments of currents in trim coils and without the correction of the RF frequency. This software makes it possible not only to form the mean magnetic field as a function of the radius, but also calculate currents in two pairs of harmonic coils from the preset values for the amplitude and phase of the first harmonic of the working magnetic field.

**Main regime:**  
 **$p, Frf = 26,26$  (MHz),  $Ek \sim 60,5$  (MeV)**

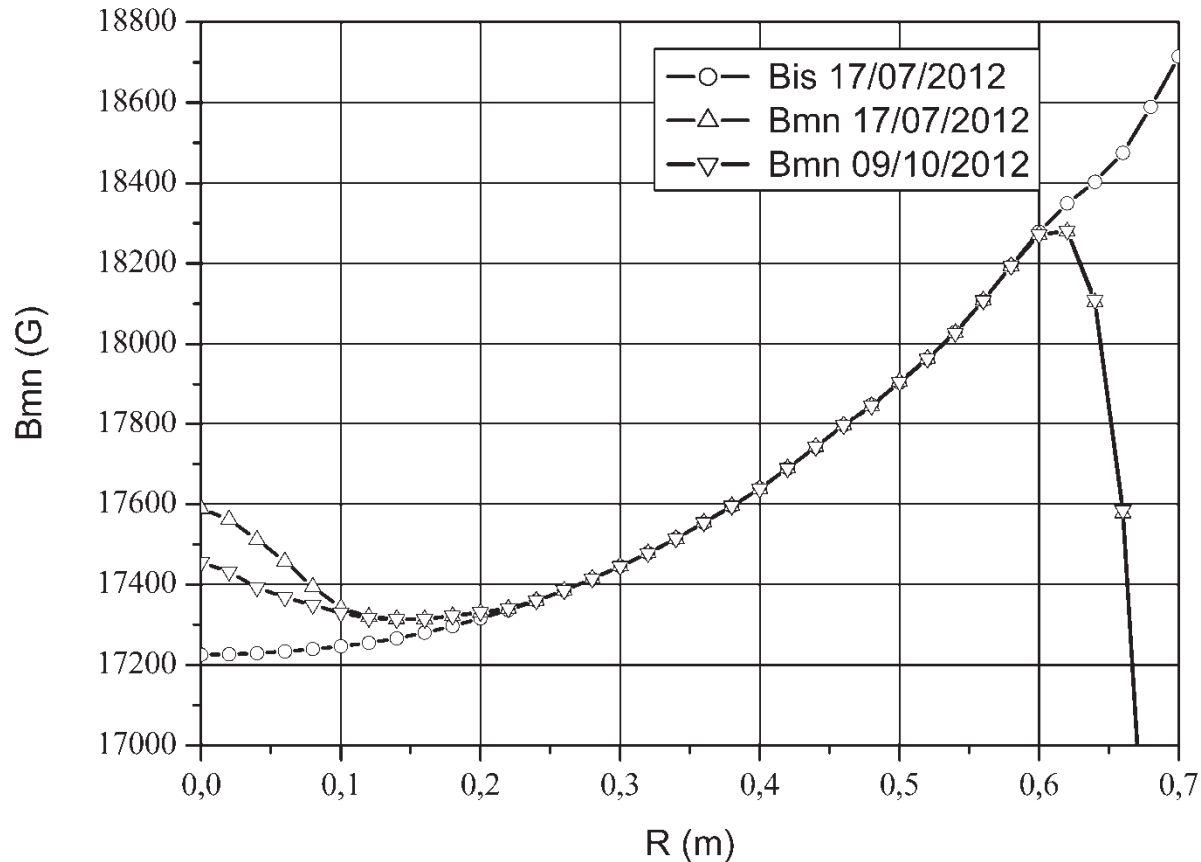

Isochronous magnetic field, a regime with the increased bump and the optimal one.

# Correction of the 1<sup>st</sup> harmonic of the magnetic field

The initial value of the 1st harmonic of the magnetic field measured in 2011 was  $\sim 13$  G at  $R = 62$  cm. It was decreased to  $\sim 2$  G by the three iterations of the horizontal shift of the vacuum chamber with iron pole sectors. The vacuum chamber was shifted by  $0.46$  mm.

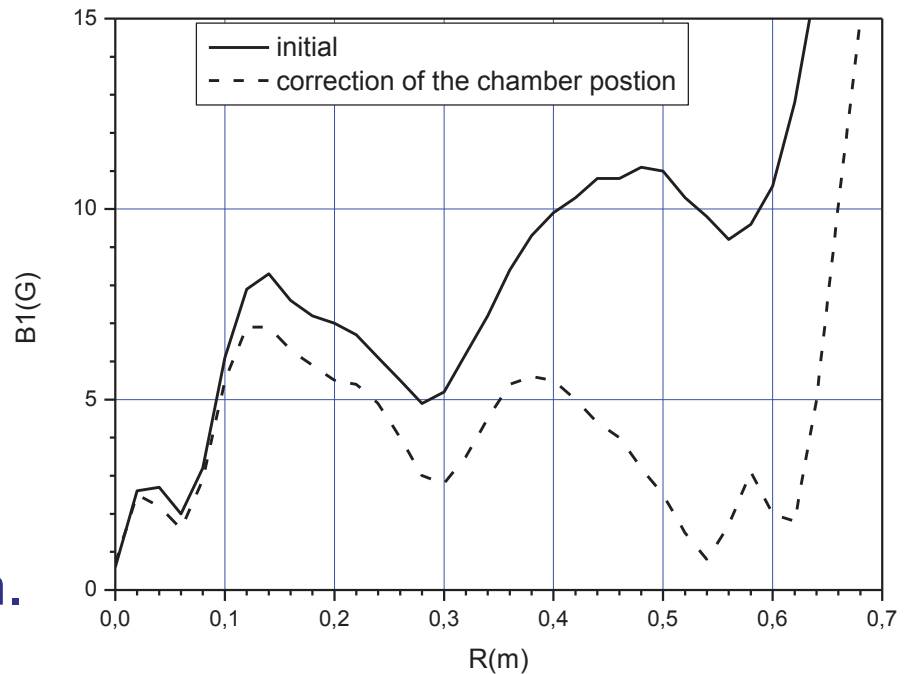
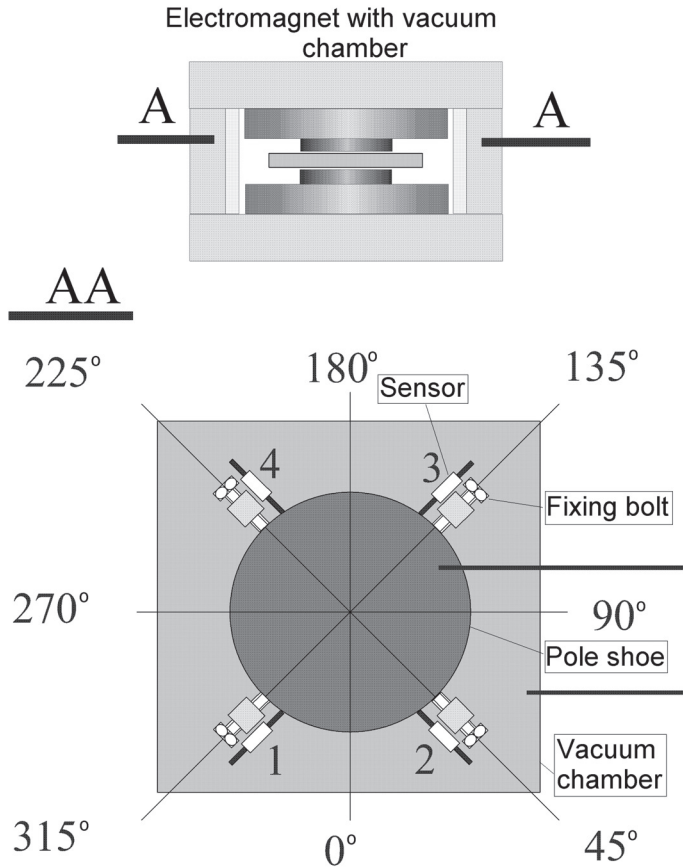

Vacuum chamber positioning system.

# EXPERIMENTAL RESULTS

Phase motion of the beam was measured with the Smith and Garren method. To implement this procedure, the beam current was measured at different radial positions of integral probe N3 at four main coil currents which were decreased step by step.

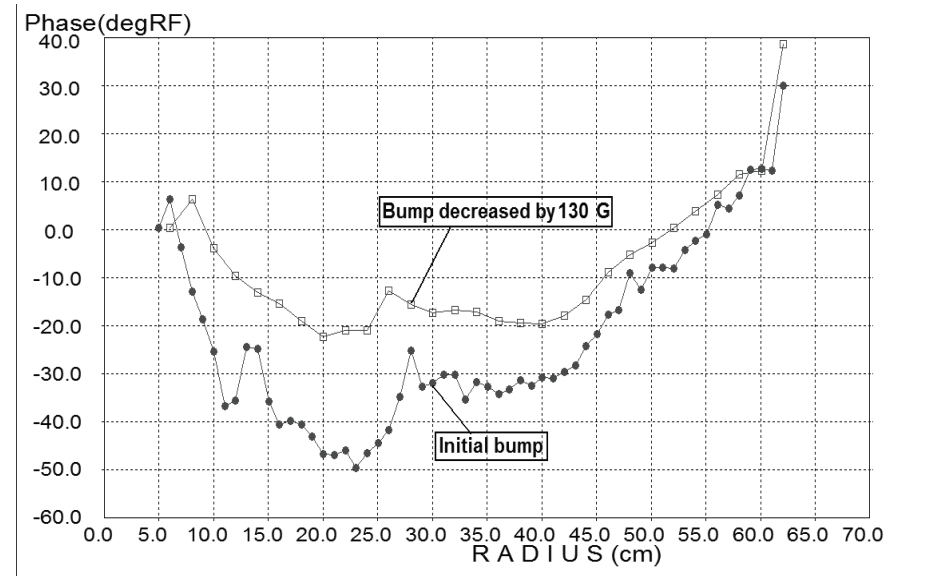
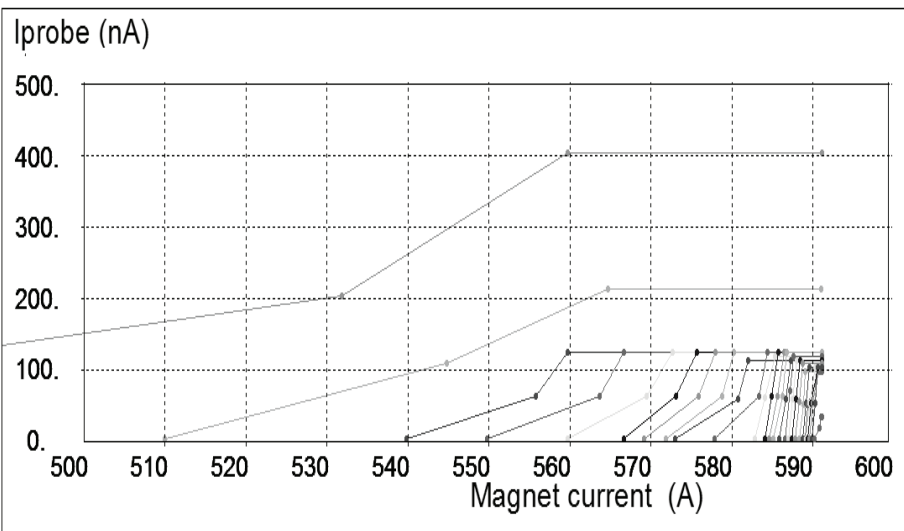

Smith and Garren curves measured for probe positions 6-62 cm.

Comparison of two phase curves for different distributions of the average field



# EXTRACTION

The best extraction efficiency was experimentally achieved by tuning the following parameters:

- bump of the magnetic field at the center of cyclotron;
- distance between the ion source and the puller;
- position of all elements of the extraction system;
- currents in the harmonic coils.

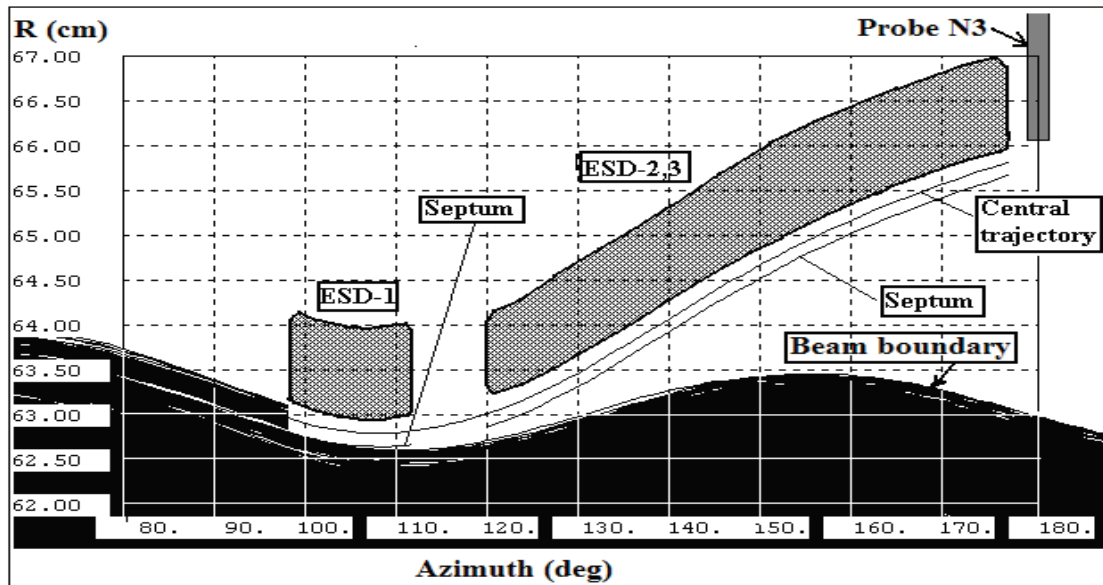

Schematic view  
of the extraction system

# Main regime: p, Frf = 26,26 (MHz), Ek ~ 60,5 (MeV)

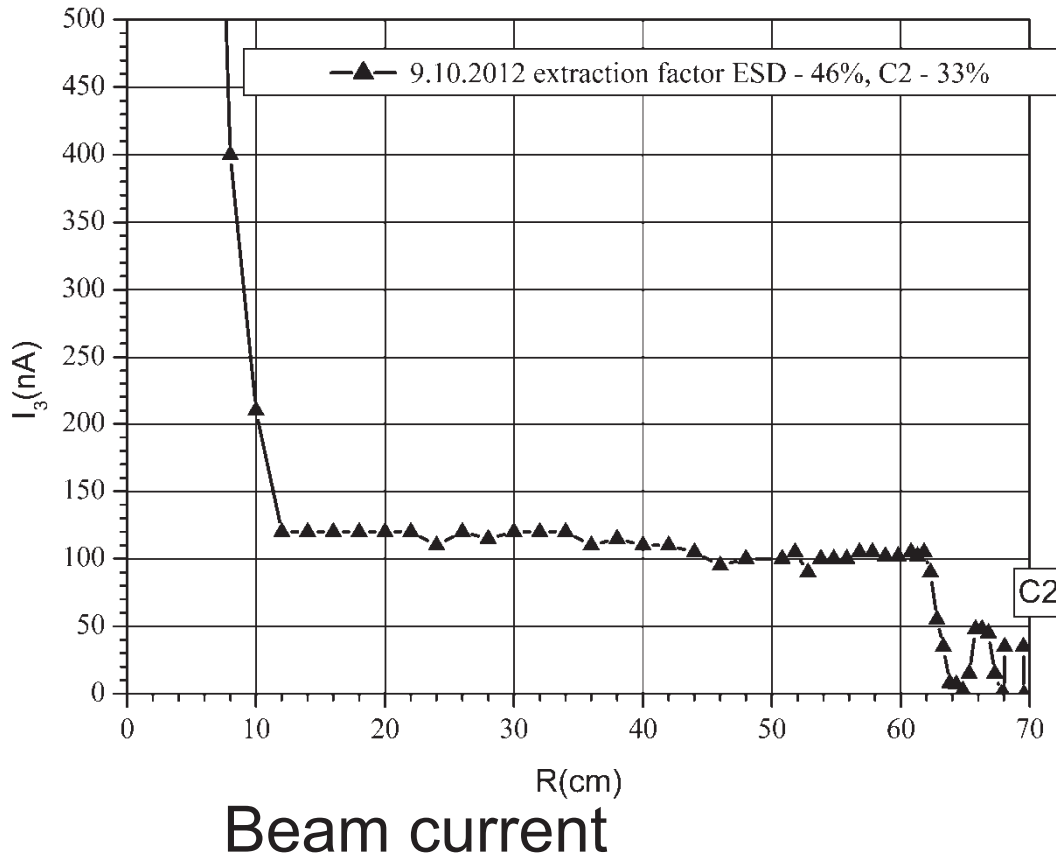

Main beam current probe N3 was used in those optimization procedures to measure the radial distribution of the beam intensity through the entire acceleration region and the extraction region as well.

# CONCLUSIONS

The experimental extraction efficiency is ~50% after two electrostatic deflectors in comparison with the internal circulating beam intensity and approaches ~35% at a point out of the cyclotron.

The beam was used for successful treatment of 15 patients in 2011-2012.



**Thank you for your attention**

CYCLOTRONS 2013