

Introduction of HIAF project

(High-Intensity Heavy Ion Accelerator Facility-HIAF)

Jiancheng Yang

HIAF general design group

**Institute of Modern Physics ,
Chinese Academy of Sciences**

yangjch@impcas.ac.cn

Outline

- **Science of HIAF**
- **Accelerator aspects of HIAF**
- **Current status of HIAF project**

Science of HIAF facility

- Nuclear physics
- High Energy Density Physics
- Science based on the EIC
- Atomic physics
- Application

Nuclear physics at HIAF

- What are the limits to nuclear existence?
- What are new forms of nuclear matter far from stability?
- How about the quantum levels far from stability?
- What are new forms of collective motion far from stability?
- What dynamical symmetries appear in exotic nuclei?
- How were the elements from carbon to uranium created?
- How is energy generated in stars and stellar explosions?
- What is the behavior of stars and supernovae?

High Energy Density Physics at HIAF

Application of ion acc. to HEDP research

- Study the Atomic Process in Plasma
- Diagnostics of HED: High Energy Proton/Ion Radiography
- Generate HED with intense Heavy Ion Beam
- Basic Knl. Fast Ignition of a compressed fuel with H.I.B.

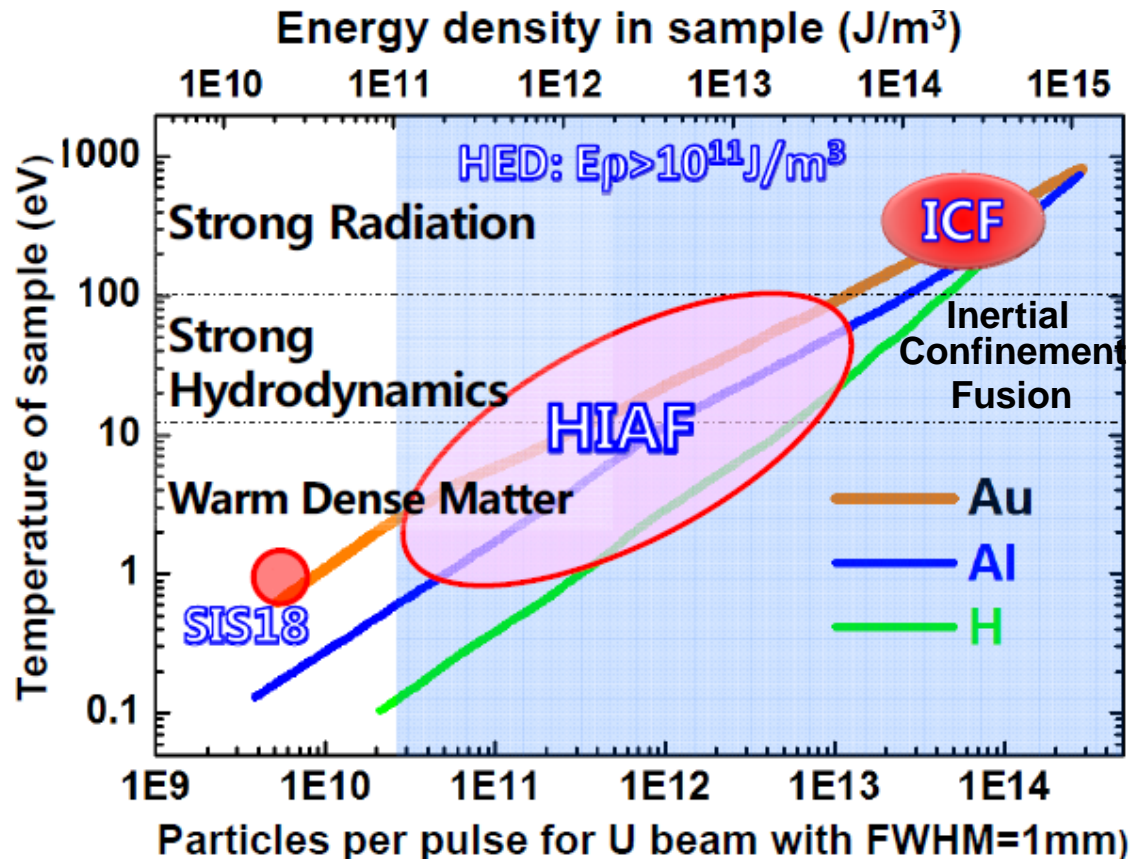

Specific energy deposition up to 0.2-2MJ/g, Target T up to 10-100eV will be possible with HIAF .

Science based on Electron Ion Collision

A High Luminosity, High Energy Electron-Ion Collider: A New Experimental Quest to Study the Sea and Glue

*How do we understand the visible matter in our universe
in terms of the fundamental quarks and gluons of QCD?*

Lepton-Proton Scattering Facilities

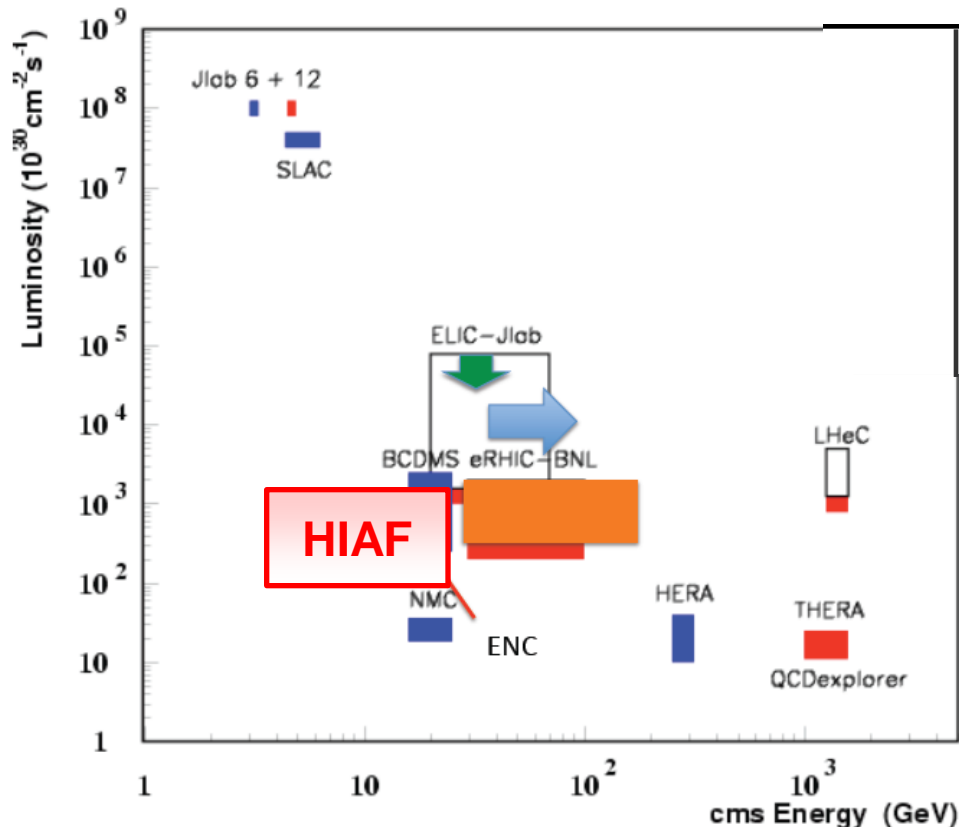

E (3GeV) + p (9.5GeV),

Polarized,

Lumi: $10^{32-33} \text{ cm}^2/\text{s}$

Atomic physics programs at HIAF

- *Quantum Electrodynamics in strong Coulomb field— $e+e^-$ pair production in heavy ion collisions*
- *Relativistic ion-atom collisions – collision dynamics at ultra short time, extremely strong electric-magnetic pulse*
- *Precision x-ray spectroscopy at relativistic ion-atom collisions*
- *Precision dielectronic recombination spectroscopy with stable and unstable ions*
- *Laser spectroscopy of ions*
 - *laser spectroscopy with radioactive ions*
 - *laser cooling and laser spectroscopy of heavy ions at relativistic velocities*

Accelerator aspects of HIAF facility

- **General discription**
- **Dynamics design**
- **Technical R&D**

The Layout of HIAF Complex

➤ Main Components:

- High intensity ion source
- High intensity pulse SC-Linac
- Multi-function booster and collector ring
- Long straight ion collider
- Figure-8 electron collider
- Large acceptance RIBs line

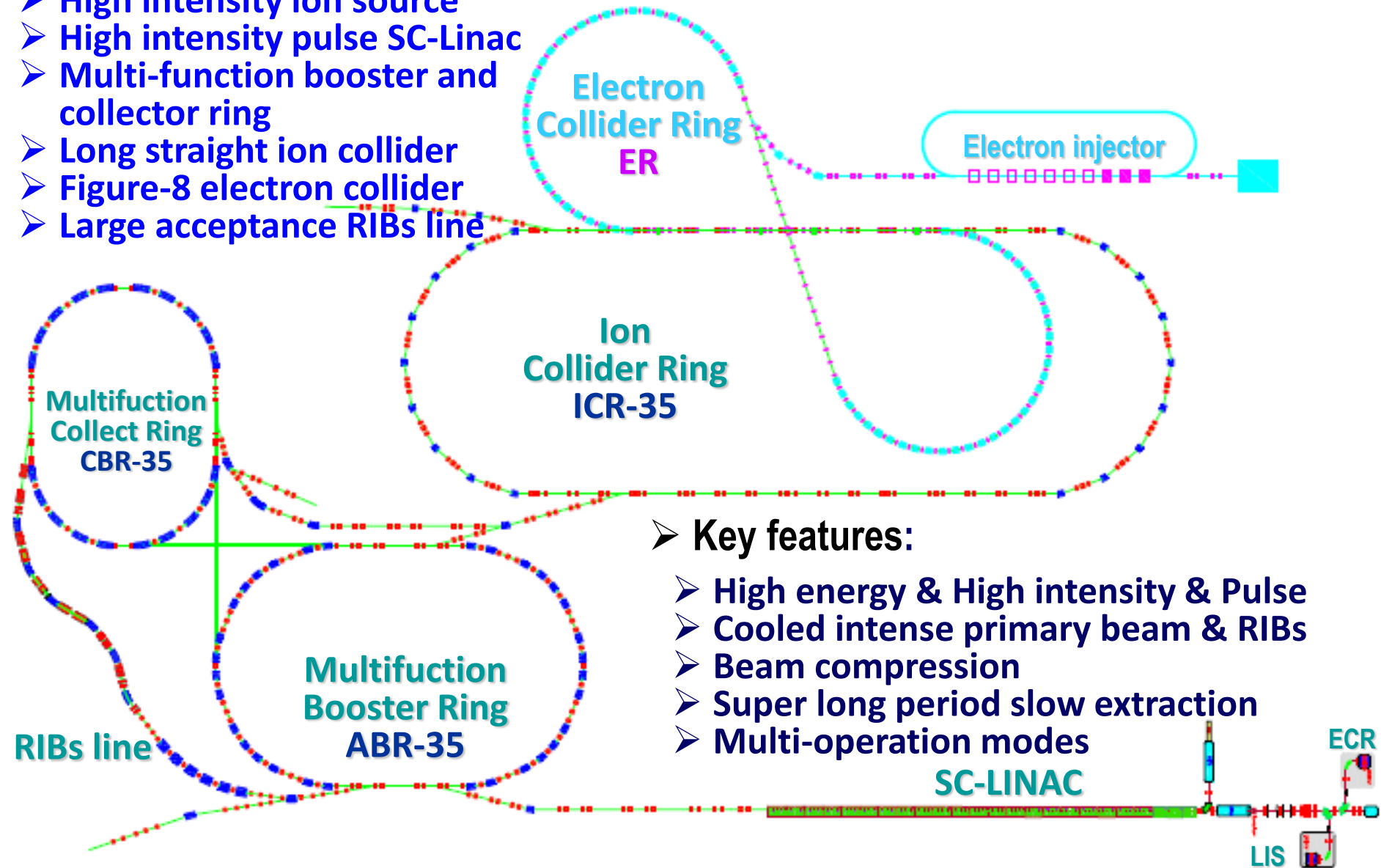

➤ Key features:

- High energy & High intensity & Pulse
- Cooled intense primary beam & RIBs
- Beam compression
- Super long period slow extraction
- Multi-operation modes

Main parameters and operation modes

Fast Extraction
Matter States
 (Dense plasma research,
 High-Energy-Density Matter)

Slow Extraction
 Material irradiation
 Space electronic device
 Application in bioscience

Atomic physics
Mass measurement

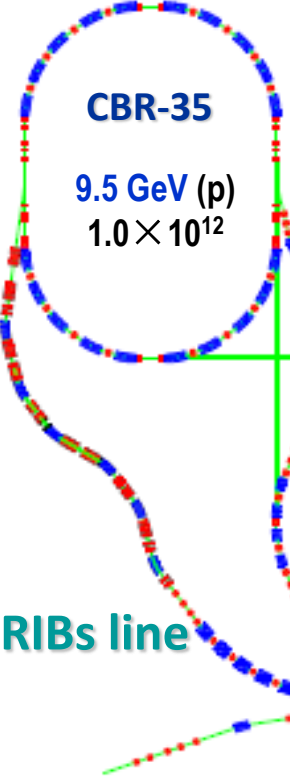

High Purity &
 Quality RIBs Station

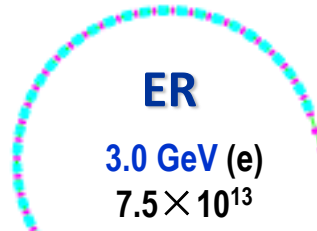

Merging

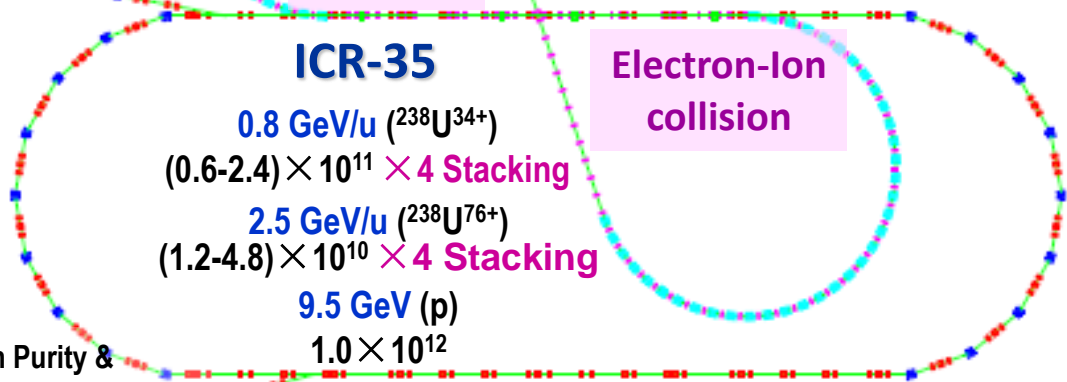

25 MeV/u
 (U^{34+})
 0.04-0.15 pA
 2 Hz, 500 μs

SC-LINAC

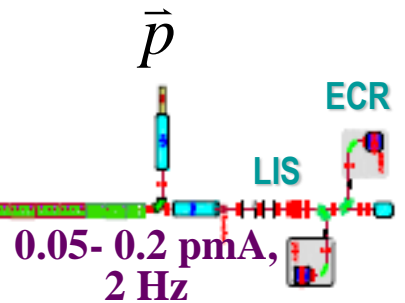

Dynamics design of HIAF

Lattice of ABR-35

Special features to meet the requirements:

- Wide energy range 0.025 -- 9.5 GeV
- Flexible adjustment of momentum compaction factor for elimination of transition energy crossing
- Dispersion free straight sections for electron cooling
- Sufficiently large dynamic aperture after sextupole correction
- Corrected chromaticity by arc's sextupoles

Dynamics design of ABR-35

“Resonant” magneto-optical lattice with controlled momentum compaction factor

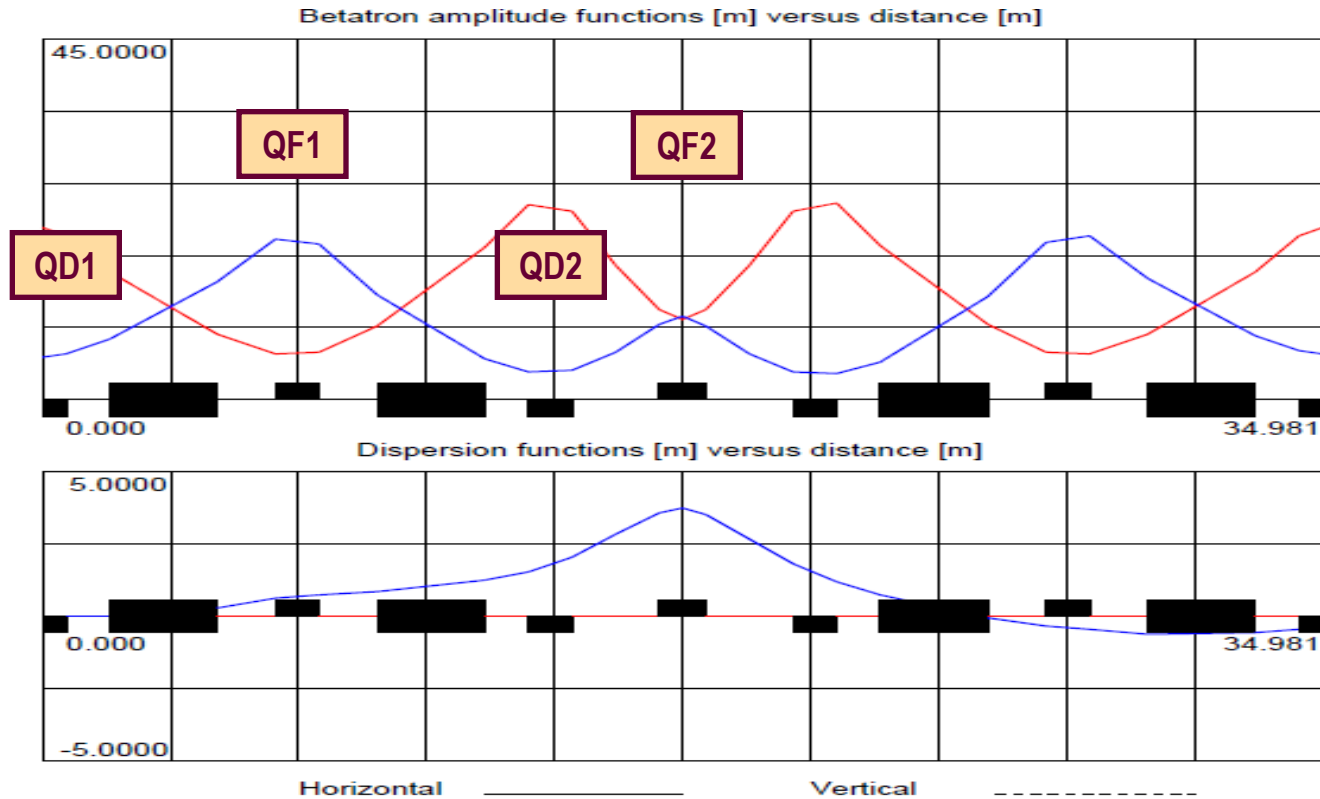

- ✧ QF1 is placed at the point of the Beta-x function maximum.
- ✧ QD1 and QD2 is placed at the point of the Beta-y function maximum.
- ✧ QF2 is placed at the point of the Dispersion function maximum.

Dynamics design of ABR-35

Painting+e-cooling Injection scheme

- ◆ Large acceptance
(500pimmmrad/120pimmmrad)
- ◆ Horizontal and vertical Painting
- ◆ Fast electron cooling

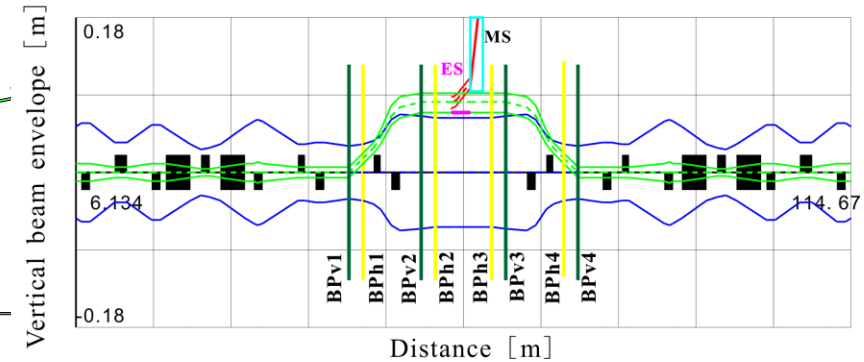
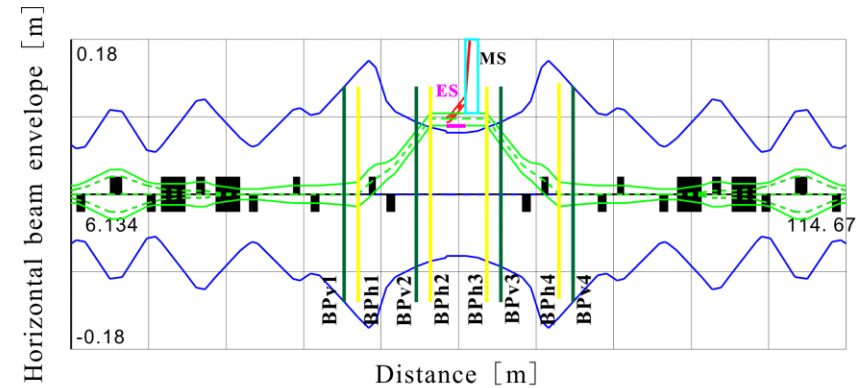
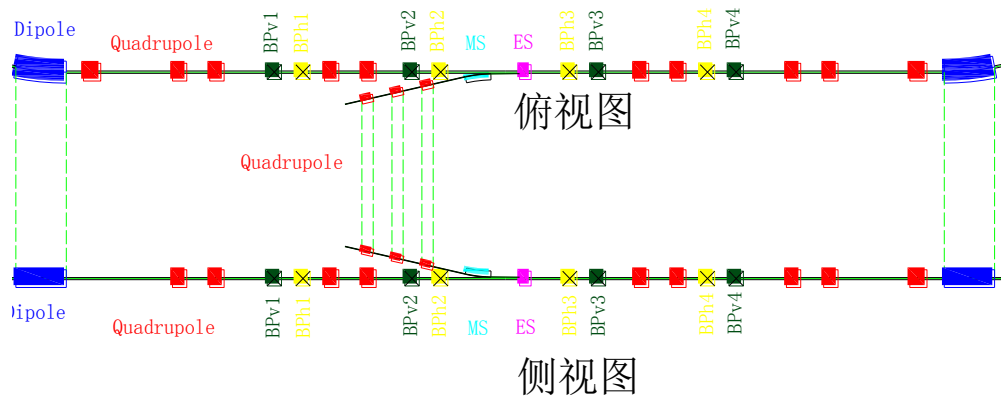

Injection components layout of
Painting+e-cooling

Orbit of Painting+e-cooling
injection

Interaction region design of EIC

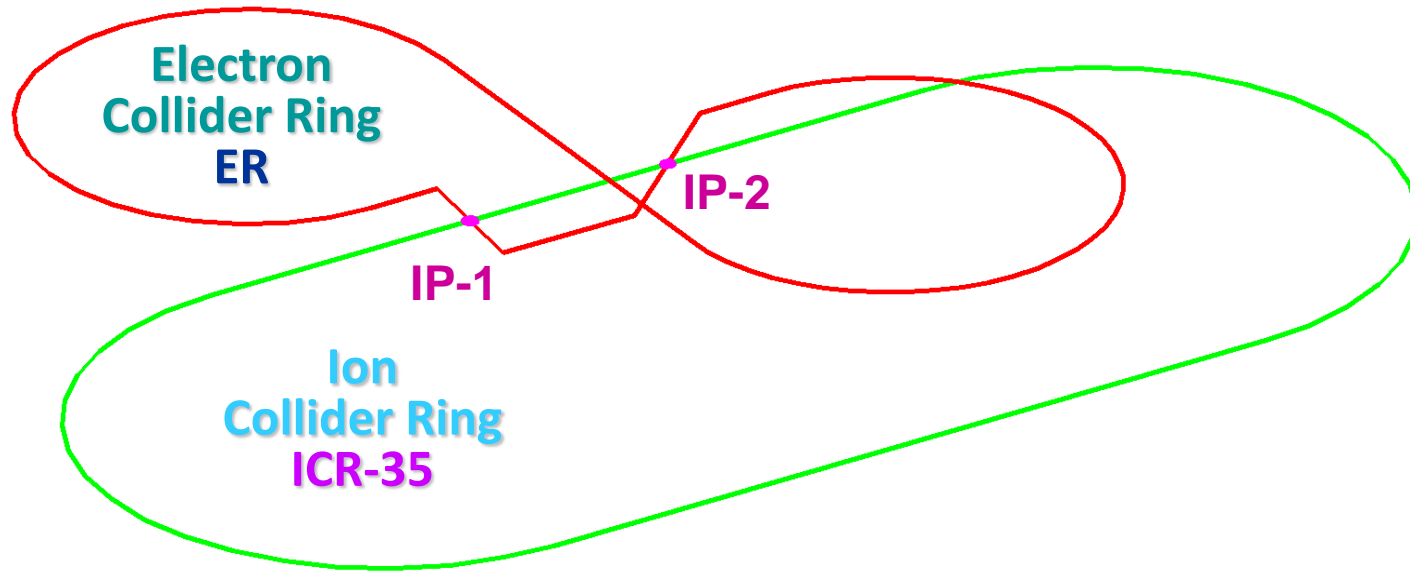

- The electron beams execute a vertical excursion to the plane of the ion ring for collision at two interaction points (IP).
- Electron collider ring with Figure-8 shape
For **spin preservation** and ease of spin manipulation (spin rotators)

Interaction region design EIC

50 mrad crossing angle with crab cavity

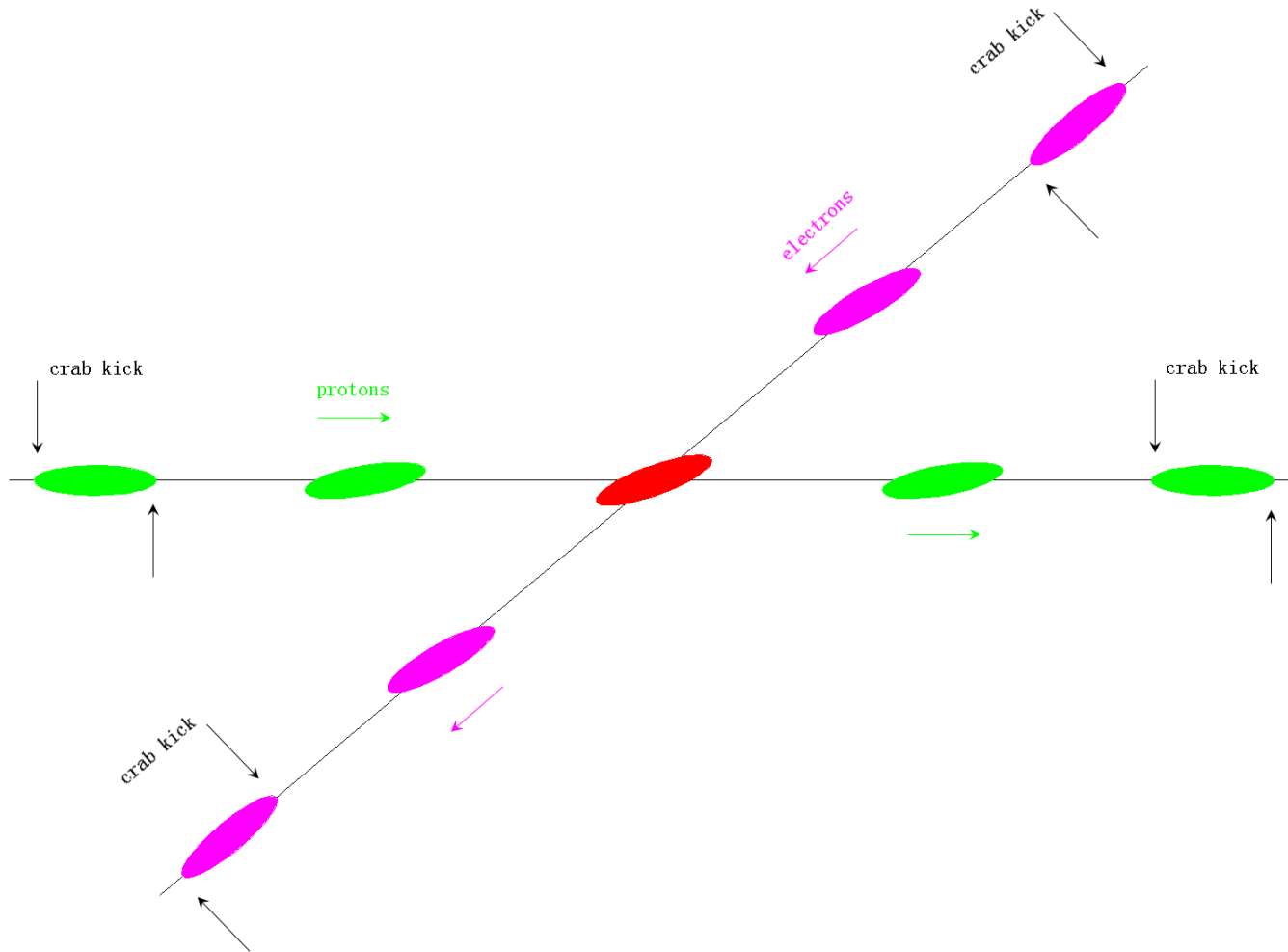

‘Crab Crossing’ is required to compensate the luminosity reduction and to avoid parasitic beam-beam interaction due to high repetition rate.

Luminosity consideration of HIAF

Guidelines:

- At low energy, we assume a round beam
- A symmetric final focusing ($\beta_x^* = \beta_y^*$)
- Assuming a little smaller emittance
- Keep Laslett tune-shift around 0.05

Luminosity bottom-line (3 GeVx12 GeV):

- Conservative estimate: $\sim 2 \times 10^{32}$
- With optimization: $\sim 4 \times 10^{32}$
- Forward-looking: $\sim 1 \times 10^{33}$
(with lots of R&D and introducing uncertainty)

		Revised	Optimized	With Traveling FF
Energy	GeV	12	12	12
Bunch repetition rate	MHz	250	250	250
current	mA	150	250	500
Protons/bunch	10^{10}	0.375	0.5	1.25
Bunch length	cm	2	2	5
Geometric Emittance, (x/y)	nm	100/50	78	78
Laslett tune-shift		0.057	0.057	0.057
β_x^* and β_y^*	cm	2/10	2/2	2/2
Beam-beam tune-shift		0.01/0.006	0.01/0.006	0.01/0.006
Luminosity, 10^{33}	1/cm ² /s	0.18	0.48	1.2

Accelerator pre-R&D

Superconducting Linac design and prototype

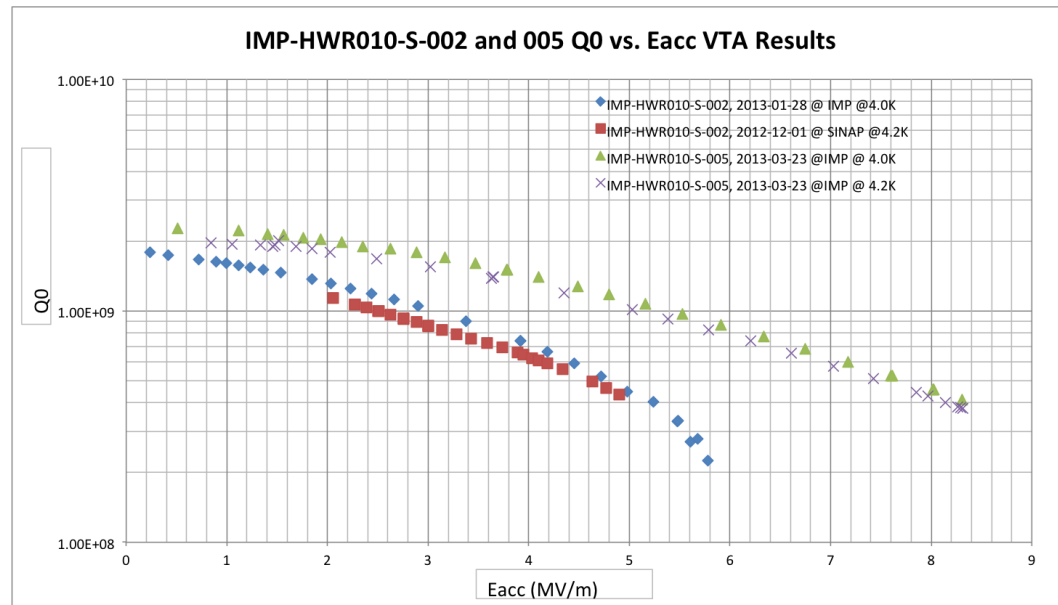
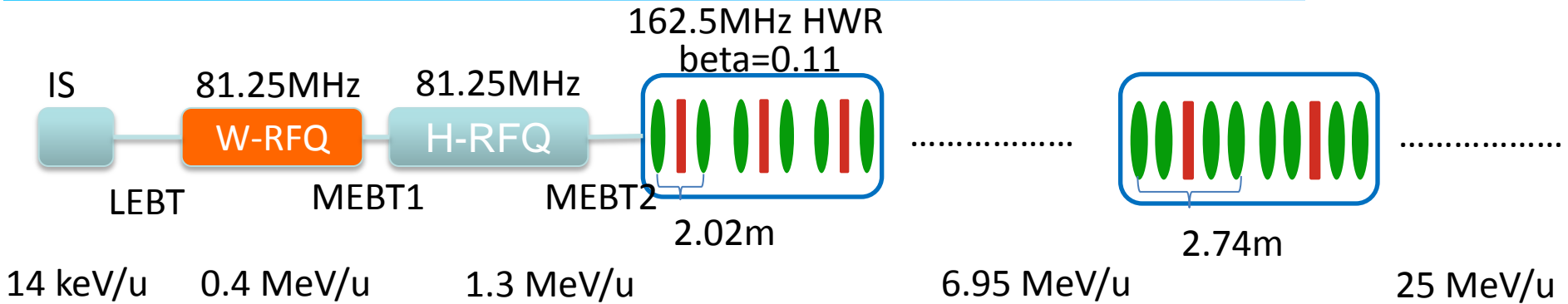

Accelerator pre-R&D

ABR-35 Superconducting Dipole

Central field	2.25 T
Useable aperture	220mm × 120mm
Max. ramp rate	2.25 T/s

- ✓ Superferric design with warm iron yoke to fulfill requirement of big aperture;
- ✓ Hollow tube superconducting cable cooling with supercritical He ;
- ✓ Strong support structure to resist strong electromagnetic force

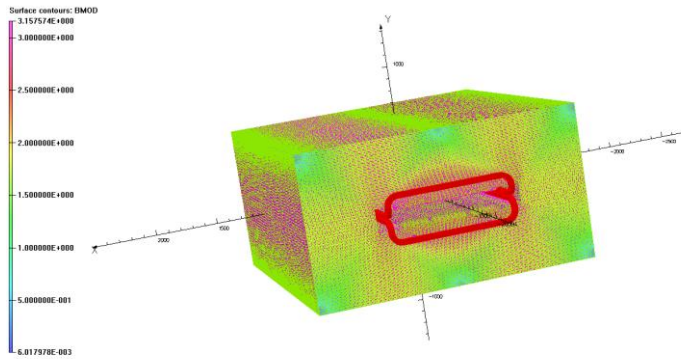

Field distribution in iron yoke

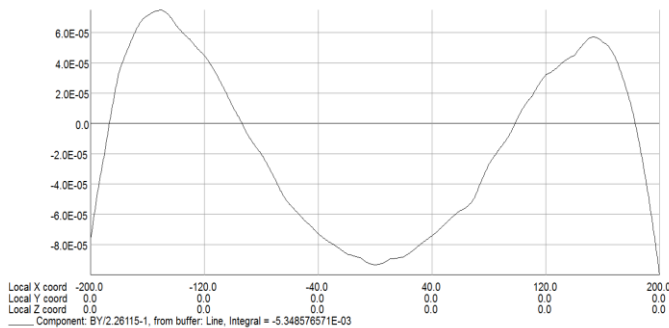

Horizontal field homogeneity

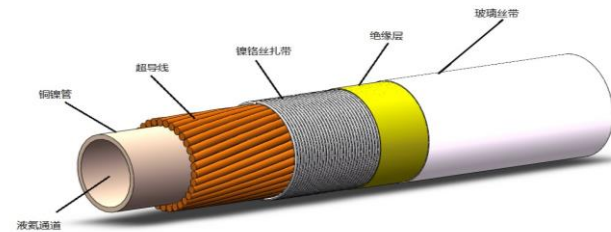

Hollow tube SC cable

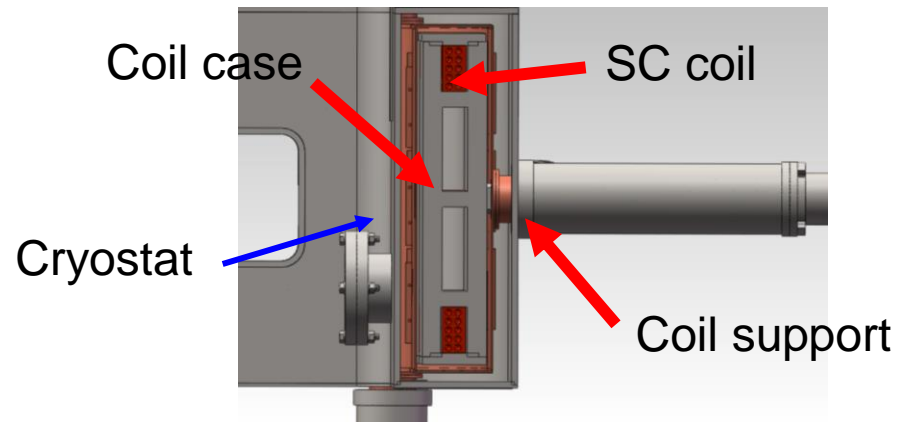

SC coil and Cryostat

Accelerator pre-R&D

ICR-35 Superconducting Dipole

<i>Central field</i>	<i>6 T</i>
<i>Useable aperture</i> (6×10^{-4})	$\Phi 70\text{mm}$
<i>Ramping rate</i>	$<1 \text{ T/s}$

- ✓ Cos θ type coil with Rutherford cable;
- ✓ Cooled with supercritical helium (4.5K);
- ✓ The cold mass consists of a superconducting coil, a reinforcing shell, cold iron yoke, etc;
- ✓ G10 post used as cold mass support;

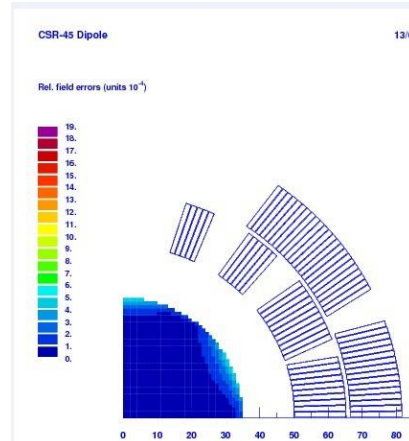

Field distribution in aperture

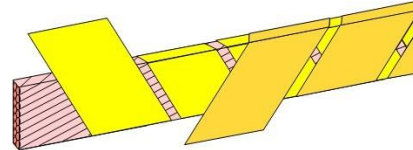

Rutherford cable

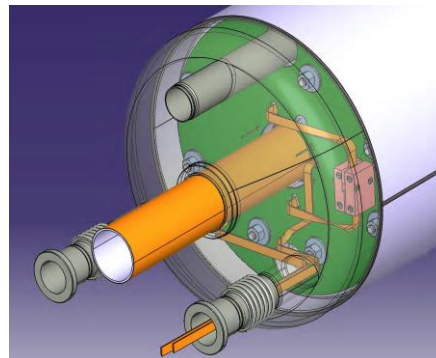

Cold mass assembly

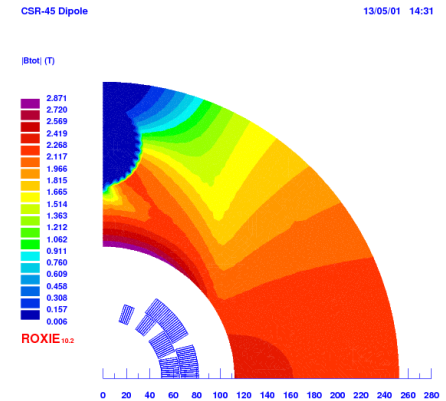

Field distribution in iron yoke

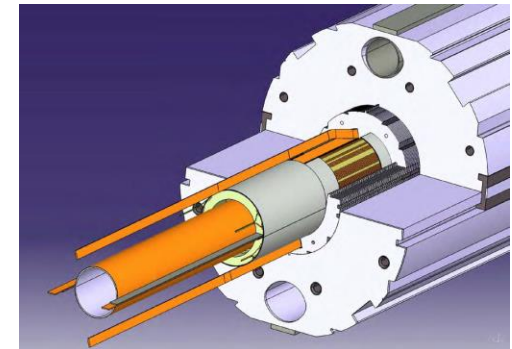

SC coil, collar and yoke

SIS 300 prototype

Accelerator pre-R&D

Electron cooling

– Electron cooling of ABR-35

The crucial point for ABR-35 injection.

– Electron cooling of ICR-35

- Low energy (several hundreds keV) to get more focused beam ions for high energy and density matter research.

- Medium energy (several MeV) electron cooling

Particularly important for preserving the collider luminosity and its lifetime by suppressing IBS induced heating:

Electrostatic accelerating apparatuses that are used for accelerating the electron beam in all existing low energy electron cooling facilities ERL circulator cooler, rely on RF or SRF technology, and also photo-cathode electron source

Coherent electron cooling, new concept, it is yet to be demonstrated experimentally.

Accelerator pre-R&D

Stochastic cooling

- A novel type of 2.76 m long slotted pick-up was developed (cooperated with F. Caspers) for CSRe stochastic cooling.

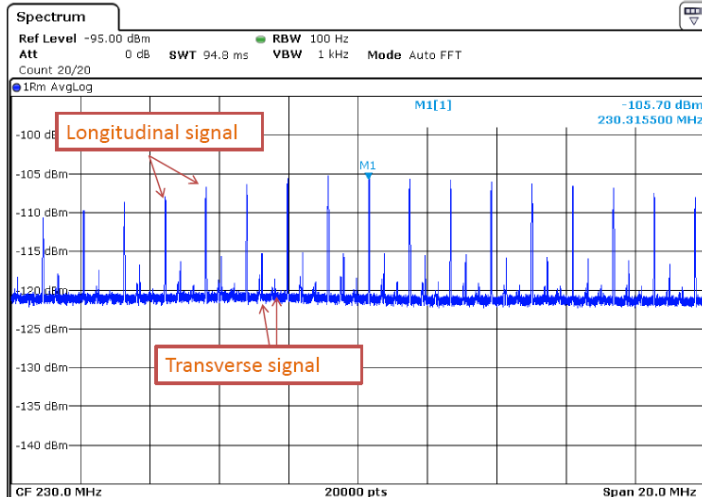
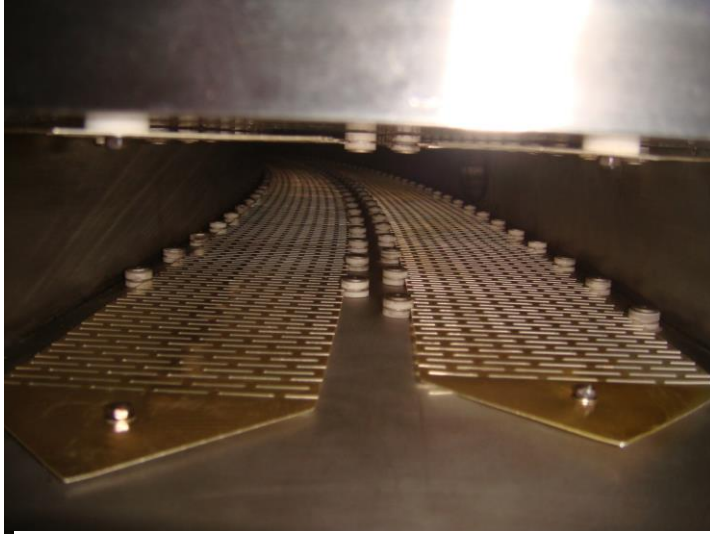

The beam test ($^{117}\text{Sn}^{50+}$, 253 MeV/u) results show it is a perfect structure for CSRe stochastic cooling.

Accelerator pre-R&D

- **Dynamic vacuum system**

- Intensity dependent beam losses for intermediate charge state heavy ion beams. The origin of these losses is the change of charge state of the beam ions at collisions with residual gas atoms
- In order to suppress and control the beam loss, a dedicated ion catcher system is necessary. Two prototypes of this catcher have been developed and installed in SIS18.

- **Collective beam effects**

- (Long time scale) beam-beam with crab crossing
- Space charge effects in ABR-35
- Electron cloud in the ion rings and mitigation

Current status of HIAF

- The HIAF project was proposed in 2009, approved in principle by the central government in the end of the 2012 and now under conceptual design stage.
- HIAF parameters will be chosen to optimize science, technology development, and project cost.
- The final design of first stage will maintain a well defined path for future upgrade to higher energies and luminosities.
- A conceptual machine design will be completed recently and provide a base for performance evaluation, cost estimation, and technical risk assessment.

Current status of HIAF

- **We seek international collaborations for key supporting technologies of HIAF.**
- **The total budget of HIAF is about \$ 380 million**
- **The timing of HIAF construction depends on the design optimization and accelerator technology R&D. We hope we can start construction in the end of 2014. Project completion is expected in 2022, managing to early completion in 2019.**

Candidate site of HIAF project

— Rongcheng city of Shangdong province



Candidate site of HIAF project

— Rongcheng city of Shangdong province

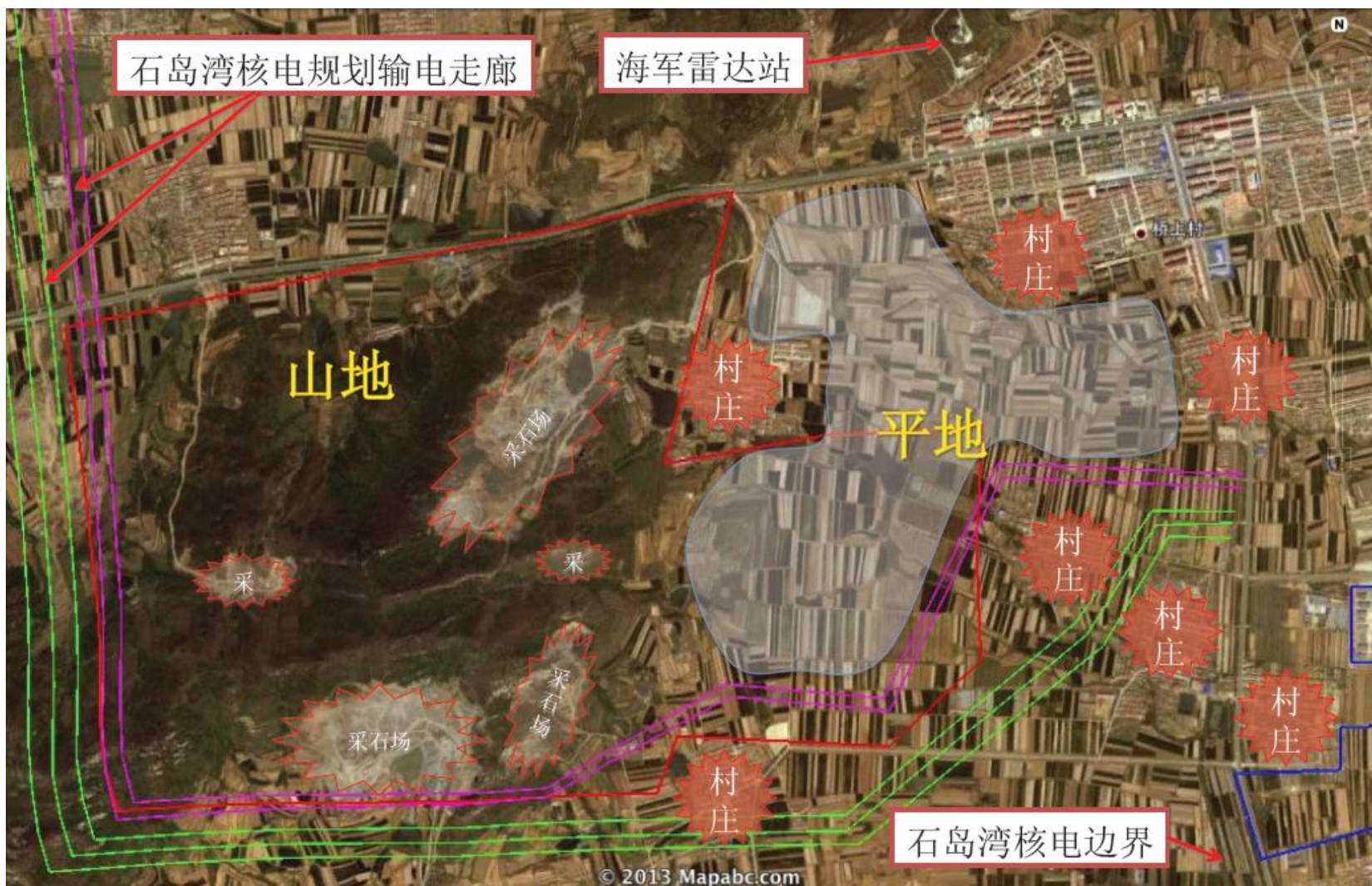

Candidate site of HIAF project

— New development area of Lanzhou city

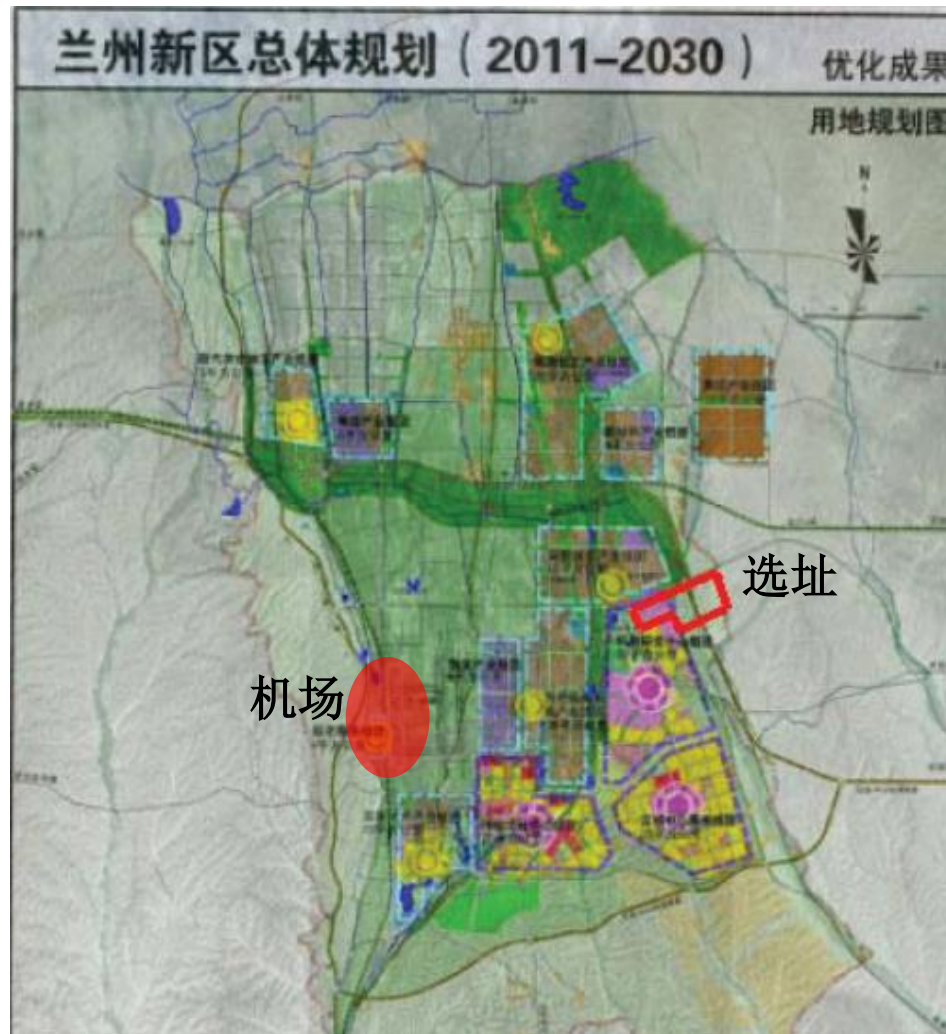

Candidate site of HIAF project

— New development area of Lanzhou city

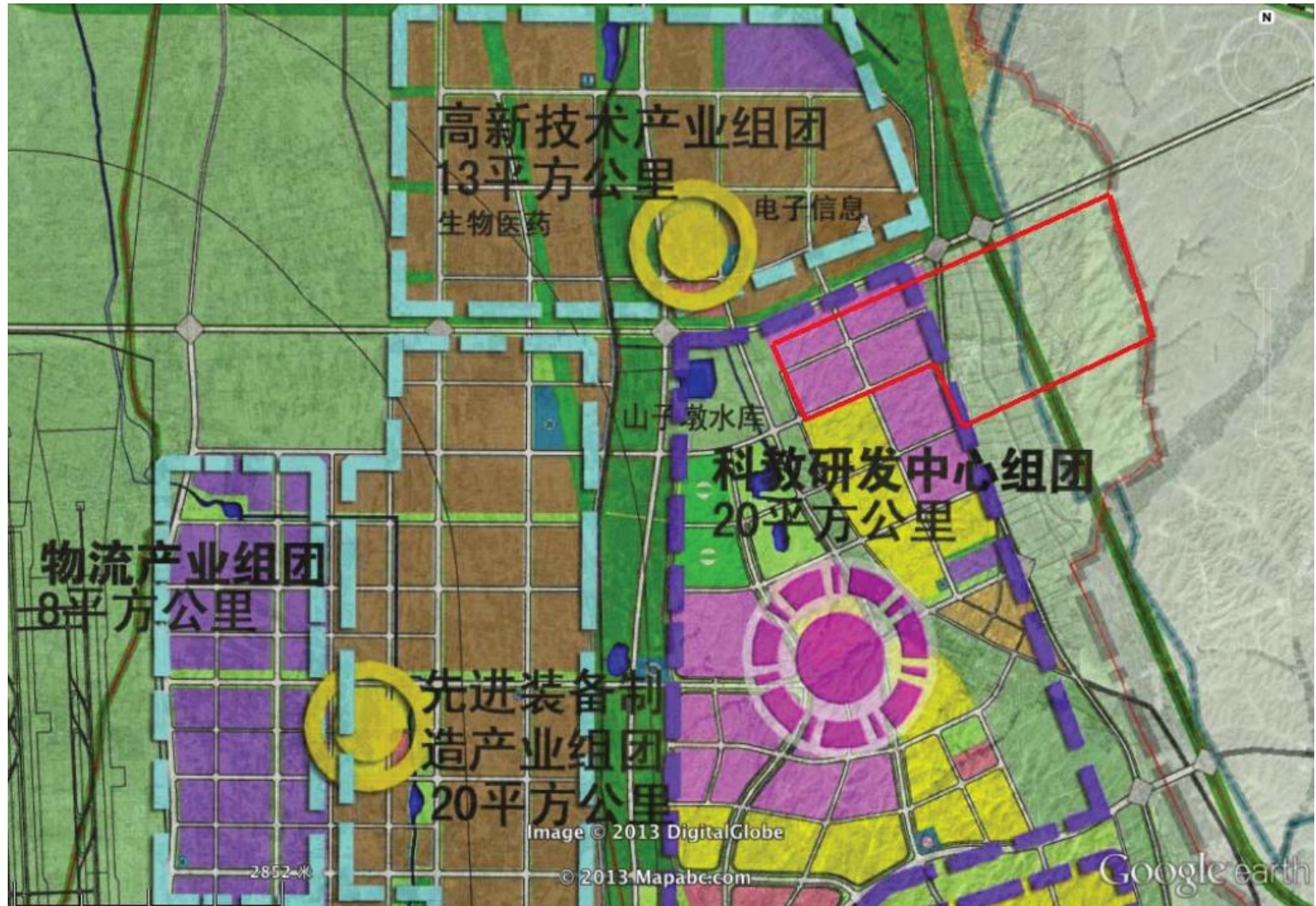

Thanks for your attention!

Any comments are welcome!

How the elements from Iron to uranium created?

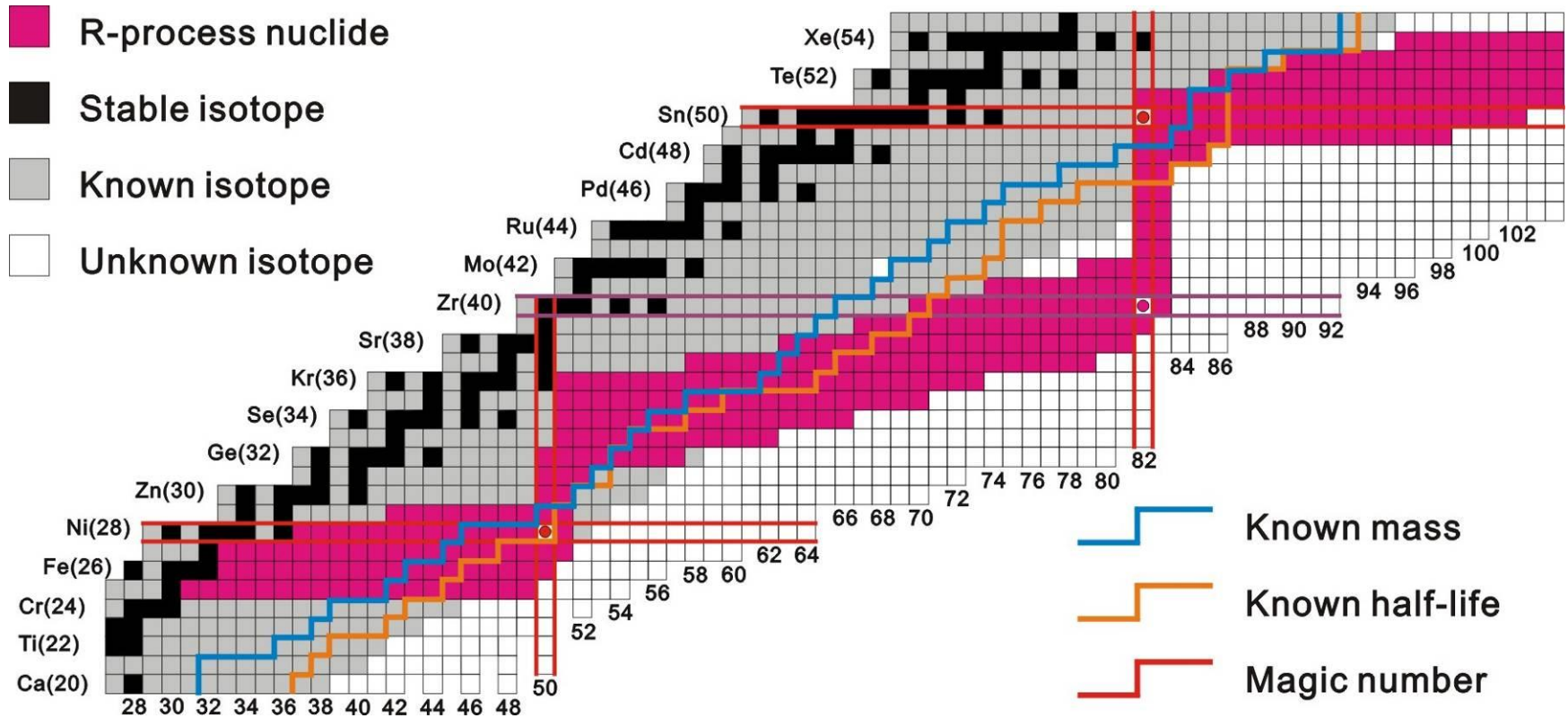

Mass and half-life measurements

Neutron capture cross section by (d, p) inverse reaction

Shell Structure Far From Stability

Methods: Mass, Reaction, Coulex, In-beam Spec., Decay Spec. etc.

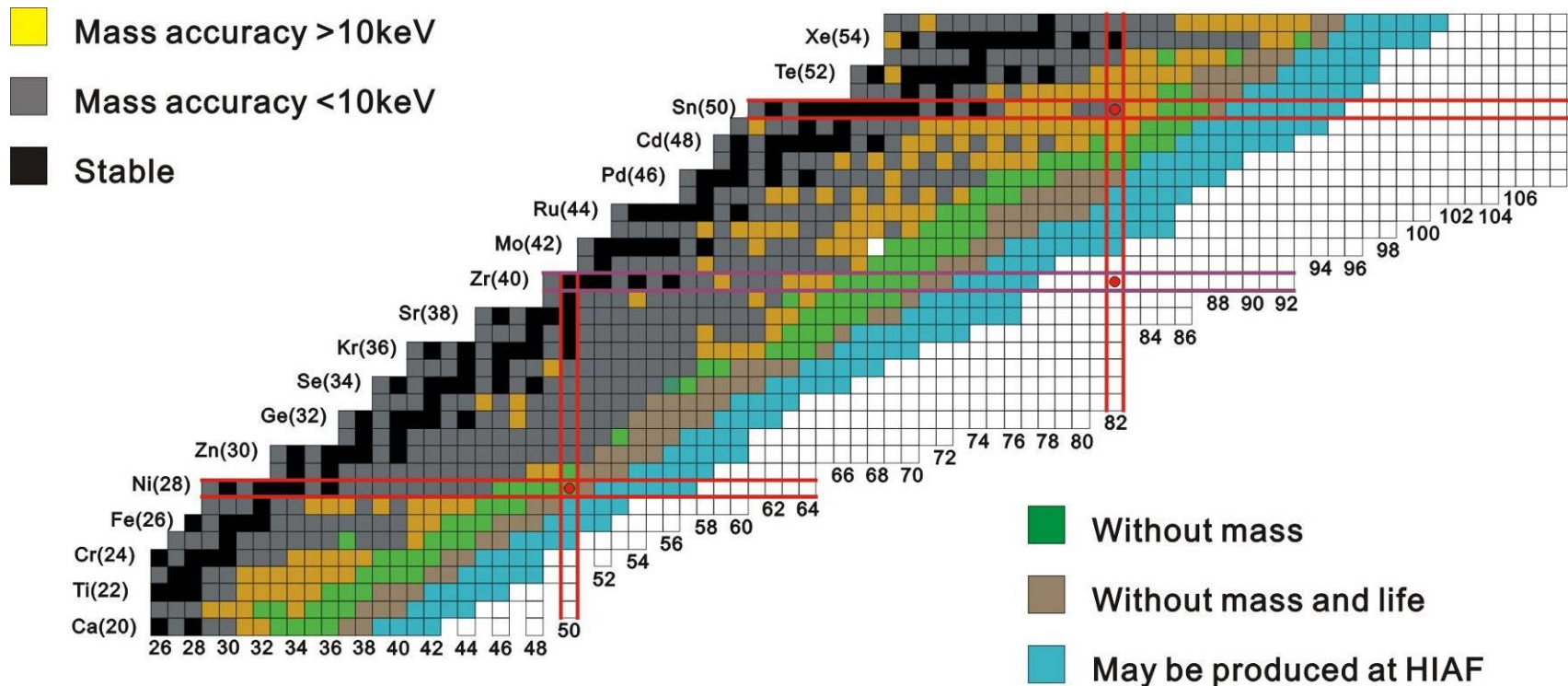

- To study the mean field at extreme isopin condition
- To study the spin-orbital angular momentum coupling
- To study the various correlations

limits to nuclear existence (SHN)

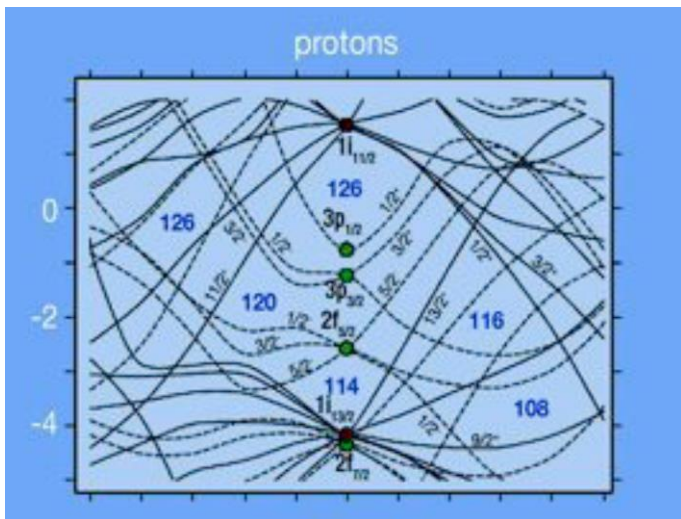
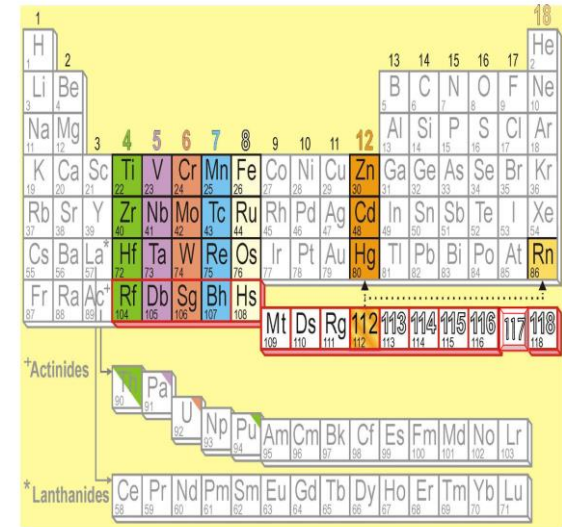
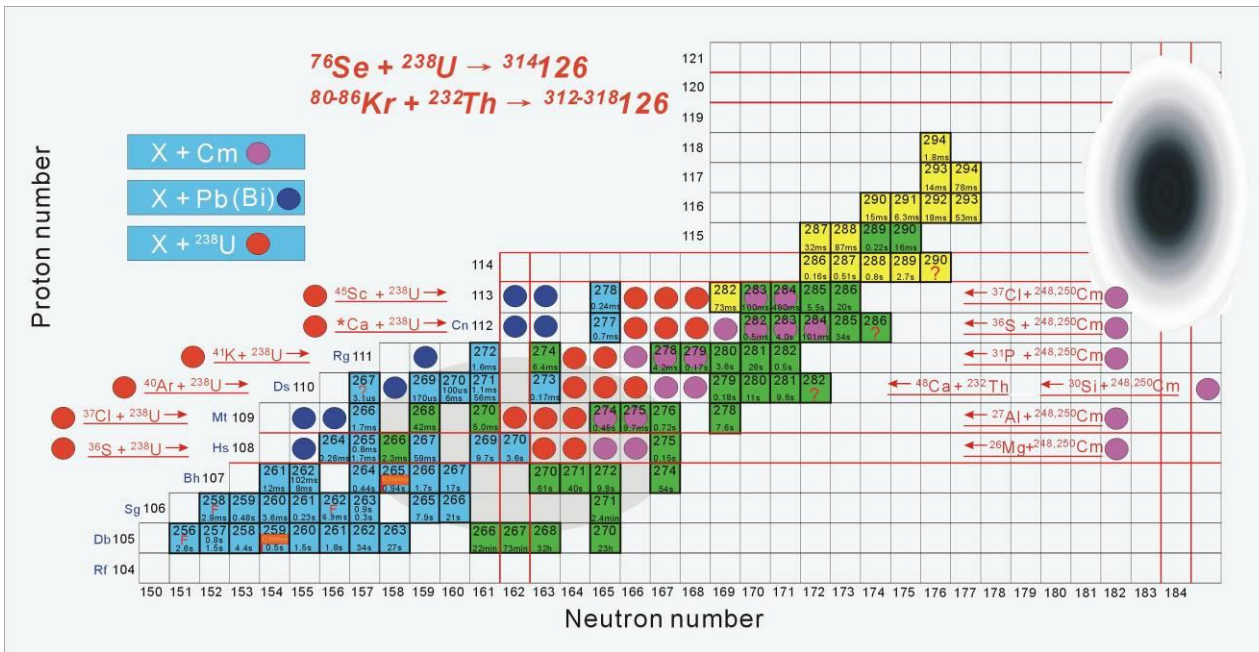

- Study the Chemical properties of SHE
- Confirm the 114-118 elements
- Explore the new elements of 120-126
- Study the reaction mechanisms
- Study the structure in heavy nuclei
- New identification methods

limits to nuclear existence (p-drip line)

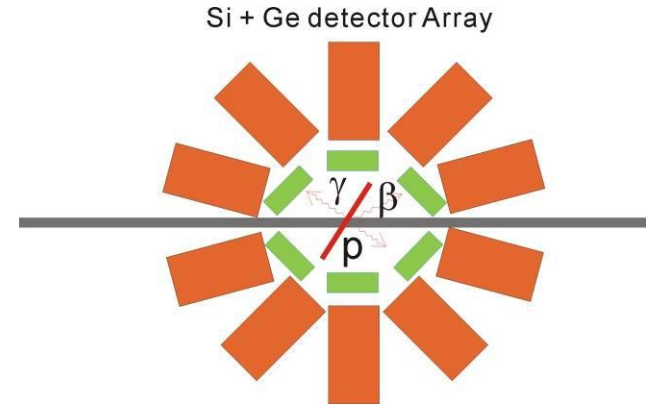
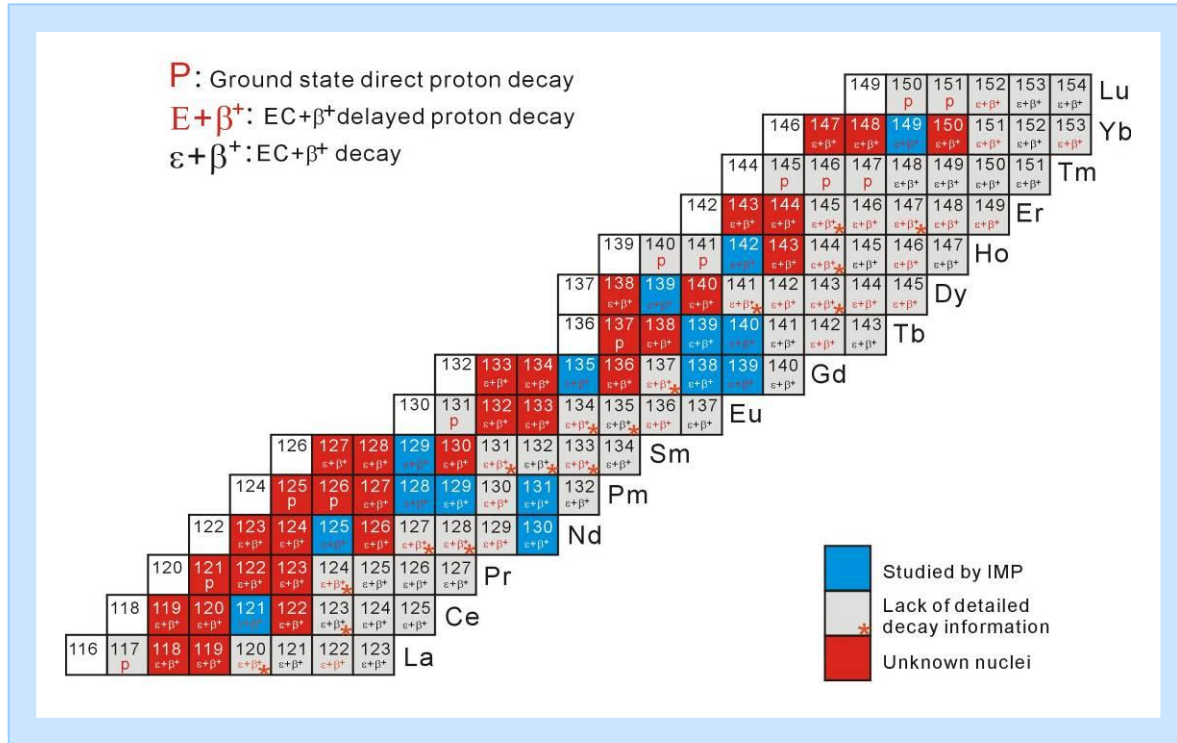

- Mapping the proton-drip line for even-Z elements
- Searching for the exotic decay modes
- Studying the various correlations at drip lines

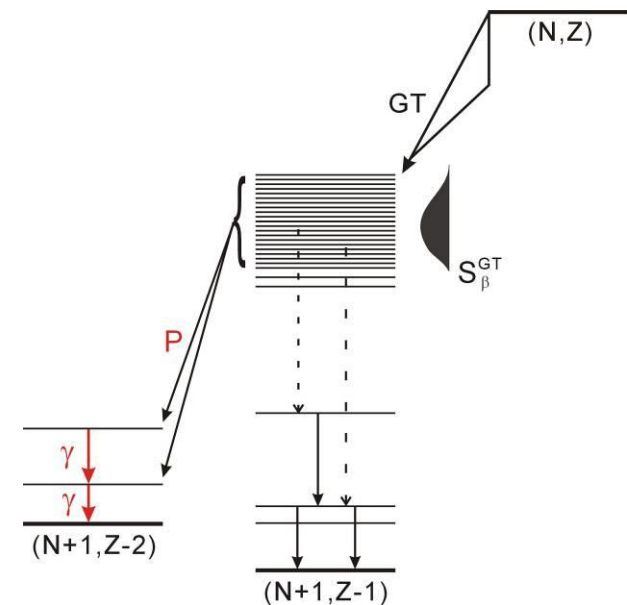

Dynamical symmetries far from stability

n-p Interaction

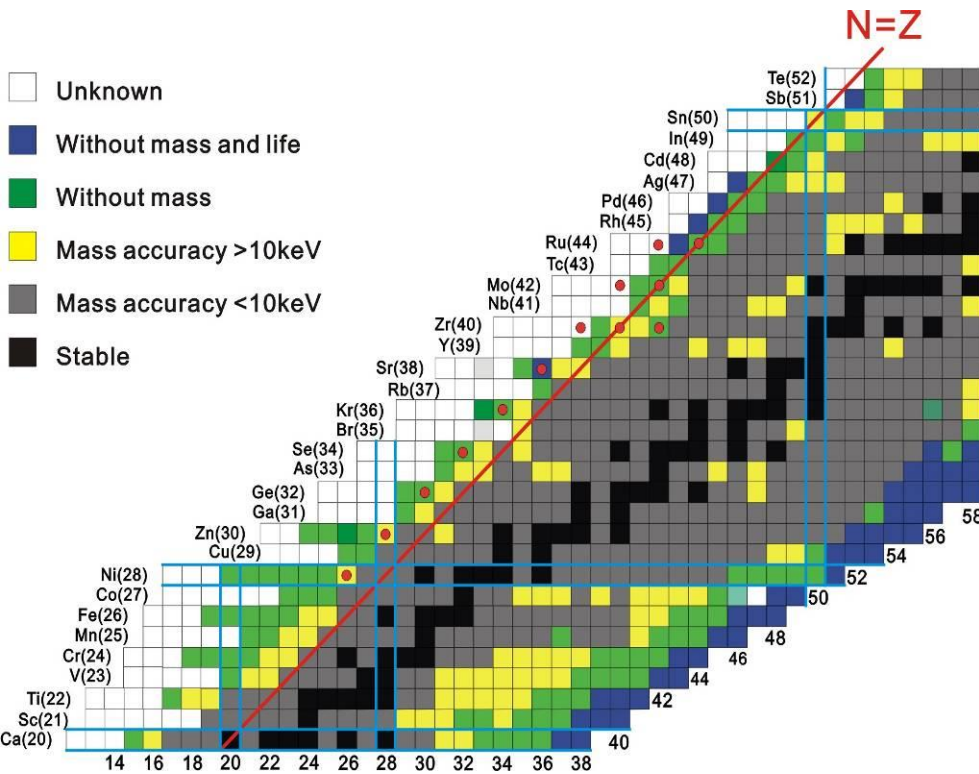

Mass Measurements

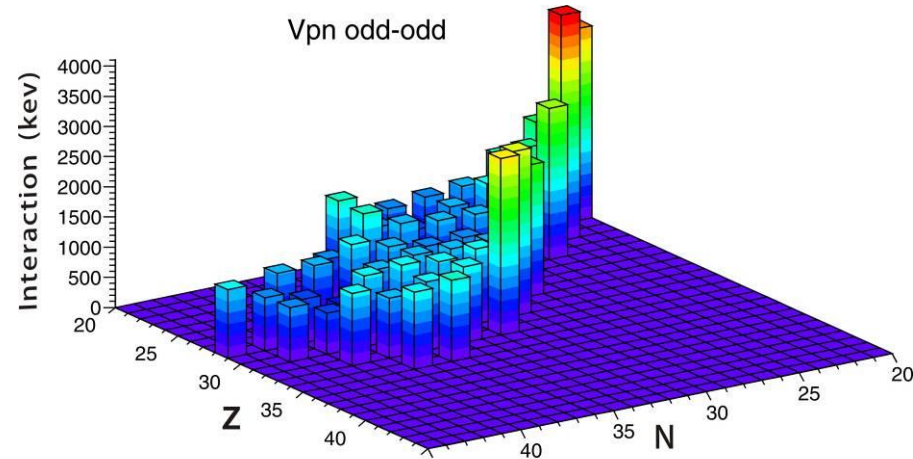

$$\delta(n-p) = [B(N,Z) - B(N-1,Z) - B(N,Z-1) + B(N-1,Z-1)]/2$$

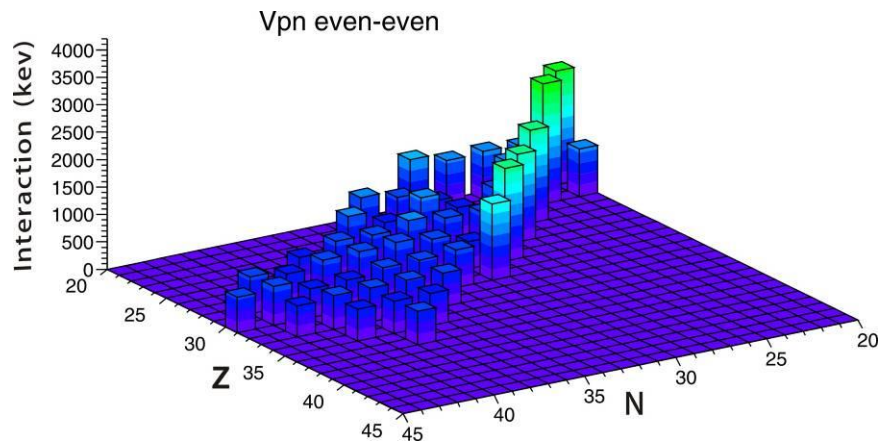

$$\delta(n-p) = [B(N,Z) - B(N-2,Z) - B(N,Z-2) + B(N-2,Z-2)]/4$$

New phenomena far from stability

Methods: Reaction, In-beam Spec., Decay Spec. et al.,

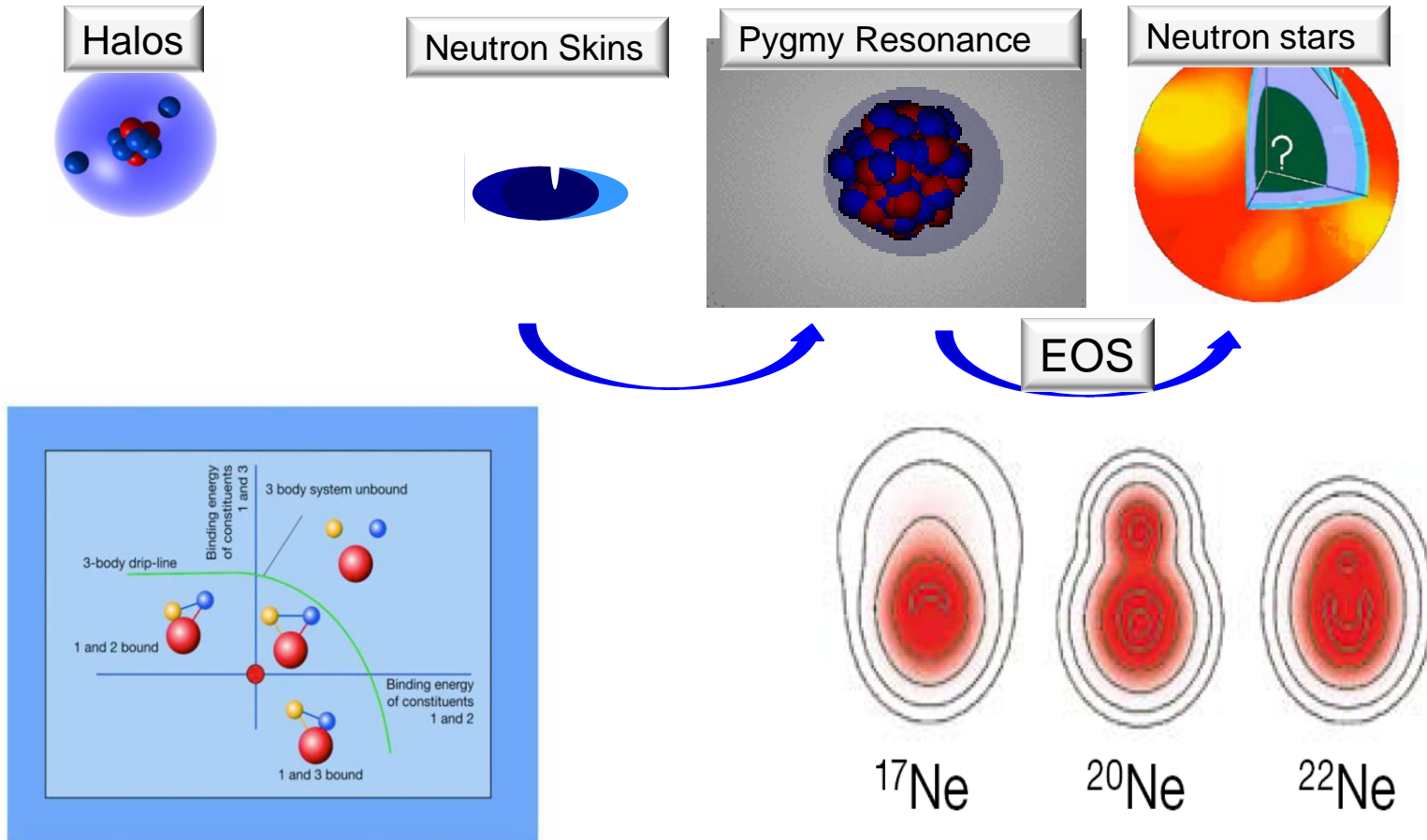

- To identify the effective forces which provide nuclear binding
- To study the exotic matter distribution and the constrain the EOS
- To study the isospin dependence of nuclear interaction

Nuclear Matter at HIAF

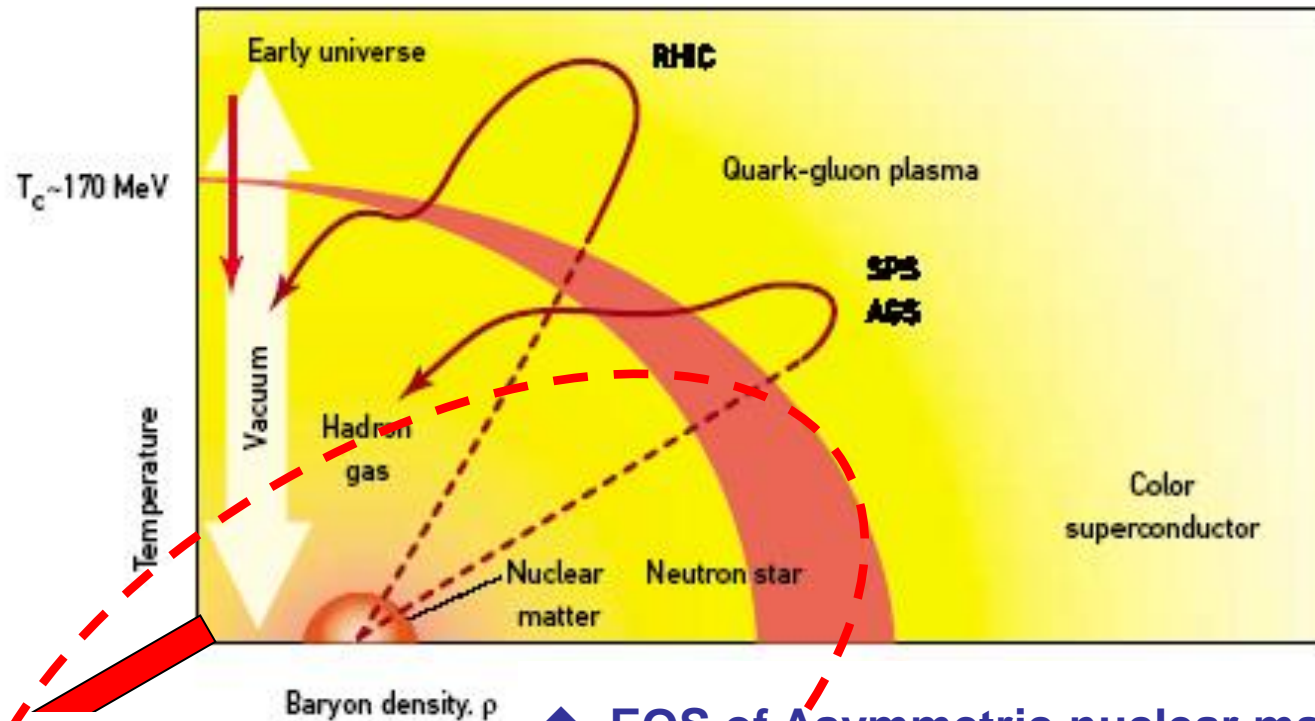

Isospin asymmetry

HIAF

- ◆ EOS of Asymmetric nuclear matter at high density and large isospin asymmetry
- ◆ Effective NN interaction in high-density nuclear medium
- ◆ Medium effect on Hadrons and partial restoration of the chiral symmetry
- ◆ Properties of neutron stars

.....