

ELECTRON COOLER FOR NICA COLLIDER

E.V.Ahmanova, A.G.Kobets*, A.V.Ivanov**, I.N.Meshkov, Parhomchuk**, R.V.Pivin,
A.U.Rudakov, A.V.Shabunov, A.V. Smirnov, N.D.Topilin, Yu.A.Tumanova, S.L.Yakovenko#,
JINR, Dubna

A.A.Filippov, M.P.Kokurkin, N.Yu.Lysov, M.M.Pashin, AREI, Moscow,

Abstract

The goal of the cooling system of the NICA collider is to meet the required parameters of ion beams in energy range of $1 \div 4.5$ GeV/u that corresponds to $0.5 \div 2.5$ MeV of the electron energy (Table 1). The electron cooler is developed according to existing world knowledge of manufacturing of similar systems. The main peculiarity of the electron cooler for the NICA collider is use of two cooling electron beams (one electron beam per each ring of the collider) that never has been done. Two versions of design of the cooling system are under consideration presently. In one scheme the acceleration and deceleration of the electron beams is produced by common high-voltage (HV) generator (Fig.1). The cooler consists of three tanks. Two of them contain acceleration/deceleration tubes and are immersed in common superconducting solenoids. The third one contains HV generator. The second scheme has two coolers (one per each ring of the collider) (Fig.2). The coolers have own high voltage systems. The electron cooler consists of two tanks. One tank contains acceleration/deceleration tubes which immersed in own magnetic field created by separated coils accommodated inside the tank.

CONCEPTUAL DESIGN OF THE FIRST COOLER VERSION

Three tanks of the electron cooler (Fig. 1) are filled with SF₆ gas under pressure of 0.8 MPa (≈ 8 at) [1]. Tanks 1 and 3 contain acceleration tube and electron gun for one of the electron beam and deceleration tube and electron collector for another one. The tank 2 houses the HV generator. The magnetic field is formed by a set of straight and toroidal superconducting solenoids. The solenoids forming the magnetic field in the region of acceleration/deceleration tubes are placed outside of the tanks that resolve the problem of HV insulation.

Table 1. Cooler parameters

Electron energy, MeV	0.5 ÷ 2.5
Electron beam current, A	0.1 ÷ 1,0
Beam diameter, cm	1,0
solenoid magnetic field, T	0.1 ÷ 0.2
HV PS current, mA	1
Collector PS, kW	2×2
HV PS stability, $\Delta U/U$	1×10^{-4}
SF ₆ gas pressure, at	5 ÷ 8

* Institute of Electrophysics and Radiation Technologies, NAS of Ukraine

** Budker Institute of Nuclear Physics

yakoven@jinr.ru

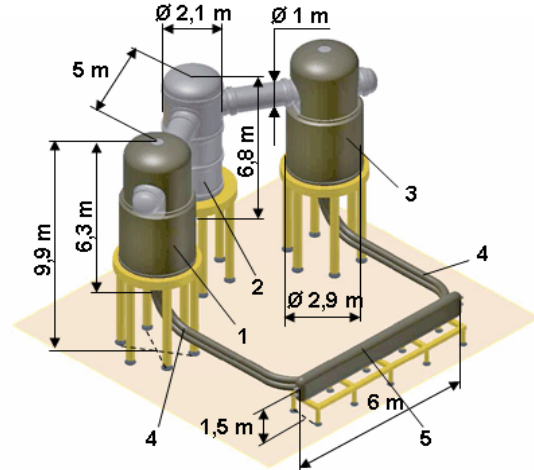

Fig.1. General view of the electron cooler. 1, 3 – the tanks with electron gun and acceleration tube and deceleration tube + collector for electron beam of opposite direction, 2 – tank with HV generator, 4 – beam transportation solenoids, 5- electron cooling section

HIGH VOLTAGE GENERATOR OF THE FIRST COOLER VERSION

High voltage (HV) generator placed in one of the tank of the cooler (Fig.2) is based on the principle of the cascade scheme [2]. The power transmission to the high potential will be provided with rotating rods (shafts) (Fig.2). The 300 kV model of the high voltage generator of the cooler (Fig.3) has been constructed and tested. Modelling of different electric processes, like HV ripples, long-term behaviour of the generator, feed-back system influence, etc., in progress.

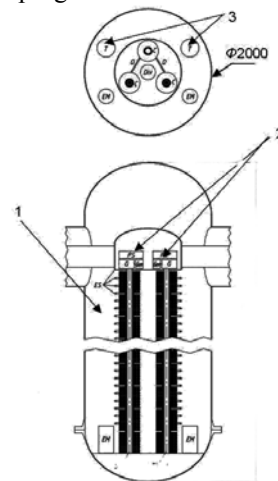

Fig.2. Design of power supply of 2.5 MV. 1 - cascade generator, 2 - gun and collector power supply, 3 - power transmitters to high potential ("shafts")



Fig.3 HV generator prototype $U=300\text{ kV}$, $I=1\text{ mA}$

CONCEPTUAL DESIGN OF THE SECOND COOLER VERSION

Second version of electron cooler consists of two independent coolers (Fig. 2, Tanks 1, 2) (one per each collider ring) with independent power supply systems. Its scheme based actually on the electron cooler design that was constructed by BINP and installed presently in COSY cooler-ring [3]. Each cooler consists of the high-pressure tank, which is filled with SF₆, and houses accelerator tubes, high-voltage sections, cascade transformer, a set of solenoids and high-voltage terminal. The high-voltage terminal comprises an electron gun, collector, Wien filter, and various power supplies for these elements. The cascade transformer is to provide a required power for the acceleration sections and high-voltage terminal. The magnetic field is generated by a set of solenoids, two solenoids per accelerator section.

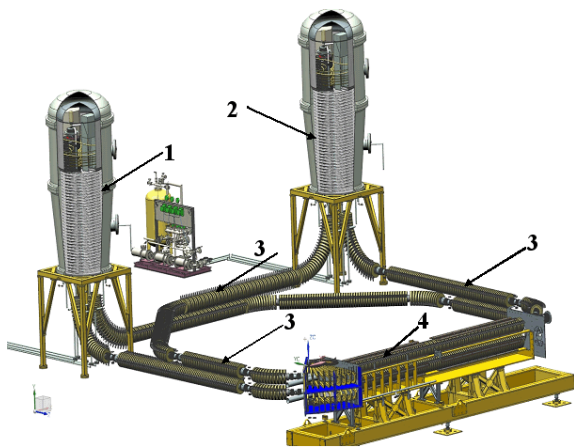

Fig.4. General view of the electron cooling system (II). 1, 2 – tanks with electron gun and acceleration tube and deceleration tube + collector, 3 – beam transportation solenoids, 4- electron cooling section

MAGNETIC SYSTEM

In both cooler versions magnetized electron beams are planned to be use. The longitudinal magnetic field is formed with superconducting solenoids – straight and toroidal ones. In the first cooler version the superconducting solenoids form the magnetic field along all electron trajectory – from the gun up to collector. The solenoids in acceleration/deceleration area are placed outside the tanks (Fig.1). In the second version the solenoids in high-voltage part are located inside the tanks (Fig.2) and are “warm” (normal conducting). Other part of the system is superconducting. Both solenoid systems have straight and toroidal sections of different diameter. Magnetic field formation at solenoids connection is done with magnetic shields (Fig.5, 6) The examples of magnetic field simulation see below.

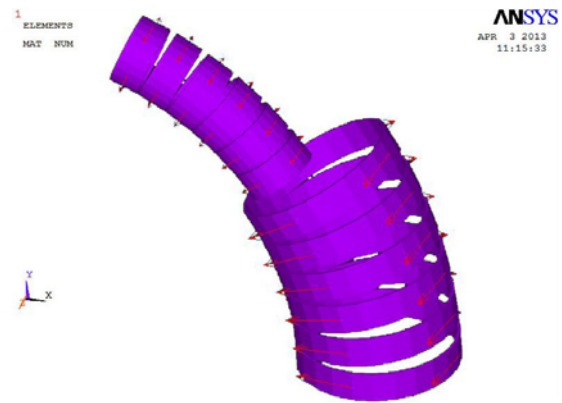

Fig. 5. The toroidal solenoids coils

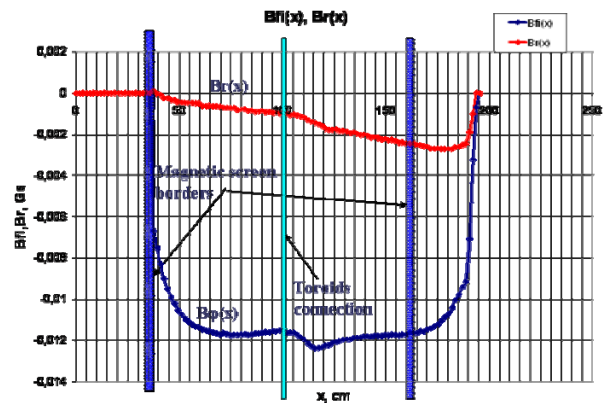

Fig.6. Magnetic field distribution on the electron beam axis near connection in the toroidal solenoids of different diameters; x-coordinate along electron trajectory

CONCLUDING REMARKS

Two alternative versions of electron cooling system for NICA collider has been proposed. Design of SC magnetic system, the electron gun and collector is in progress. 300 kV HV e-cooler model has been constructed, tested and under further developed.

REFERENCES

- [1] E.V. Ahmanova, et. al./ “Status of the high voltage electron cooler project for NICA collider”, [http://accelconf.web.cern.ch/accelconf/](http://accelconf.web.cern.ch/accelconf/RUPAC12) RUPAC’12 , TUACH01, p.58-59.
- [2] E.V. Ahmanova, et. al./ “Electron cooler for NICA collider”, [http://accelconf.web.cern.ch/accelconf/](http://accelconf.web.cern.ch/accelconf/COOL11) COOL’11 , TUPS13, p.125-128.
- [3] M. Bryzgunov, et. al./ “High voltage electron cooler”, [http://accelconf.web.cern.ch/accelconf/](http://accelconf.web.cern.ch/accelconf/RUPAC12) RUPAC’12 , TUXCH01, p.38-42.