

# PRELIMINARY MECHANICAL DESIGN STUDY OF THE HOLLOW ELECTRON LENS FOR HL-LHC

C. Zanoni\*, G. Gobbi, D. Perini CERN, Geneva, Switzerland  
 G. Stancari, FermiLab, Batavia (IL), USA

## Abstract

A Hollow Electron Lens (HEL) has been proposed in order to improve performance of halo control and collimation in the Large Hadron Collider in view of its High Luminosity upgrade (HL-LHC). The concept is based on a hollow beam of electrons that travels around the protons for a few meters. The electron beam is produced by a cathode and then guided by a strong magnetic field. The first step of the design is the definition of the magnetic field that drives the electron trajectories. The estimation of such trajectories by means of a dedicated MATLAB® tool is presented. The influence of the main geometrical and electrical parameters is analyzed and discussed. Then, the main mechanical design choices for the solenoids, cryostats gun and collector are described. The aim of this paper is to provide an overview of the feasibility study of the Electron Lens for LHC. The methods used in this study also serve as examples for future mechanical and integration designs of similar devices.

## INTRODUCTION

Hollow electron collimation is a novel technique [1–4] based on a magnetically confined beam of electrons traveling around the proton axis. The electrons are emitted by a cathode and then compressed and confined into a long strong solenoid. The electrons dissipate their energy on a metallic collector with an active cooling system. Such a system has recently been proposed for the Large Hadron Collider at CERN [5] and its feasibility is being investigated.

With a HEL, the particles of the protons bunch halo are kicked transversely while the core remains unaltered. The most evident advantage of hollow electron collimation is that the electron beam can have a radius close to the proton beam dimension, avoiding the limitations of mechanical devices.

To avoid stressing the integration at the proposed location in LHC, the final design of the HEL should be as compact as possible, still fulfilling the required 3 m of electrons and protons parallel and centred trajectories [5].

The trajectory of the electrons is driven by the magnetic field generated by a set of solenoids. The solenoid in which the cathode is located is called gun solenoid (GS), the long one that confines the e-cloud is called main solenoid (MS). Intermediate solenoids (BS) are also foreseen in order to keep the electrons on the defined path, Fig. 1.

A magnetically confined electron beam closely follows the field lines of the solenoid field [6]. For instance, if the axial field  $B$  increases, the requirement of a null magnetic field divergence implies that the transverse size  $r$  of the beam must decrease to conserve the product  $Br^2$ . Therefore, the

dimensions of the electron beam in two points along its path follow the equation:

$$\frac{r_0}{r_1} = \sqrt{\frac{B_1}{B_0}} \quad (1)$$

where  $r_0$  and  $r_1$  are the radii of the electron beam in point 0 and 1 and  $B_0$  and  $B_1$  are the magnetic fields in points 0 and 1, respectively. The GS is divided in two parts: a tunable field solenoid around the e-gun cathode (GS<sub>c</sub>) and a constant field solenoid aligned with the first one (GS<sub>i</sub>).

Table 1 provides the fields, currents and dimensions of the solenoids. Some solenoids are defined by the current rather than the field. In fact, the BS is constrained to the same current of the MS, that defines a field that depends on the relative position. Table 2 gives the nominal proposed dimensions of the electron beam in the main solenoid and some parameters of the cathode.

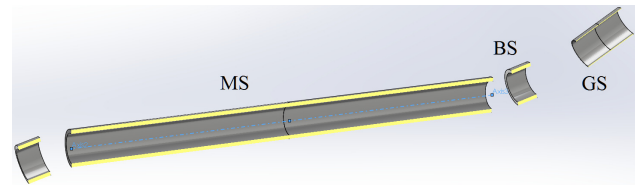

Figure 1: Open view of the solenoids configuration.

## ESTIMATION OF ELECTRON TRAJECTORIES

The trajectory of the electrons is estimated in order to obtain a first guess of the mechanical configuration of the solenoids, which has tight constraints to fit in LHC. The sensitivity of the electron trajectory to the main geometrical parameters is also derived. The numerical computations are carried out with MATLAB® and occasionally with Comsol 5.2®. A full beam dynamics assessment, including self fields, is foreseen for the future.

The electrons are emitted by the cathode and travel toward the MS. In the simulations an emission point is located on the GS axis and we check that the trajectory of the electrons is centred on the axis of the MS. To keep the beam magnetized and to mitigate its space-charge evolution, the magnetic field experienced by the electrons should always be  $\geq 0.1$  T. The following assumptions are introduced to simplify the computations:

- a single particle instead of the cloud of electrons, is considered. The mutual interaction between particles is then neglected as well as the influence of the proton

\* carlo.zanoni@cern.ch. Research supported by the HL-LHC project.

Table 1: Currents and Magnetic Fields

Solenoid	Requirement	Derived	$r_{int}$	$\Delta r$	length
MS	4 T	159.5 A/mm <sup>2</sup>	99.5 mm	20 mm	3016 mm
BS	159.5 A/mm <sup>2</sup>	2.5 T	109 mm	20 mm	150 mm
GSi	94 A/mm <sup>2</sup>	0.4 T	110 mm	4.8 mm	200 mm
GSg	0.2 T	25.9 A/mm <sup>2</sup>	110 mm	4.8 mm	200 mm

Table 2: Dimensions of the Hollow Electron Beam and of the Emitting Cathode

$r_{int}$ hollow electron beam @ nominal fields	0.9 mm (3 $\sigma$ )
$r_{ext}$ hollow electron beam @ nominal fields	1.8 mm (6 $\sigma$ )
Inner diameter of the cathode	8.05 mm
Outer diameter of the cathode	16.1 mm
Nominal current at the cathode	5 A
Nominal energy at the cathode	10 keV

beam and of the metal vacuum pipe. This particle represents the center of the hollow cloud;

- the calculation is nonrelativistic;
- ambient disturbances are neglected.

This simplified approach allows an accuracy of the solenoids position in the order of the mm that is sufficient for drafting the concept configuration and mechanical design.

The trajectory is calculated by combining the Newton-Lorentz equations with the Biot-Savart law. The motion of the electron is integrated by means of the Boris algorithm [7, 8]. We decided to fix the radii and the nominal currents according to considerations of other nature such as field compression factor, magnetic energy and reasonable space available and focus on the compactness of the design.

The design concept foresees the BS at the inlet and outlet of the MS. These solenoids are tilted and are powered with the same current of the main one in order to bend the electrons with a strong field. The GSg has 0.2 T around the gun, which guarantees the correct compression factor. At this point only the inclination ( $\alpha_g$ ) and the position along  $z$  ( $z_g$ ) of the gun are free parameters. Parameter  $z_g$  is zero in the mid plane of the MS. The simulations suggest that, to guarantee a trajectory that passes in the center of the MS, only the  $[\alpha_g, z_g]$  pairs of Fig. 2 are allowed.

A value of  $\alpha_g = \pi/6$  is chosen as it is considered sufficiently small to avoid excessive bending of the electrons. In fact, it allows the curvature of the trajectory to maintain the same sign between the GS and the BS. Table 3 shows the gun position in the proposed design with and without bending solenoids. It is clear that this second case is not an option. The magnetic field lines as simulated in COMSOL and the electron beam center trajectory are shown in Fig. 3 and Fig. 4.

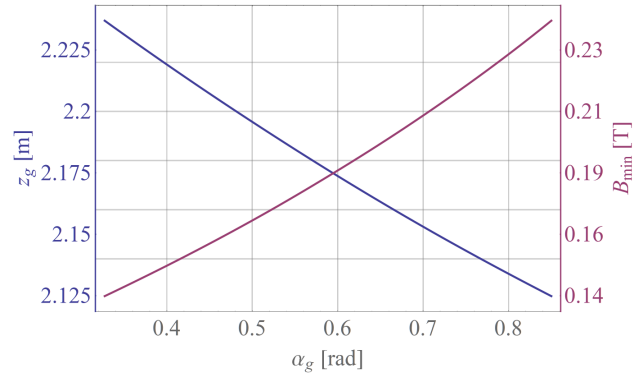

Figure 2: Correlation between distance of the GS and their angle (blue). The minimum field encountered with that configuration is also estimated (red).

Table 3: Comparison of Design Concepts

Concept	$z_g$ [m]	min B [T]
with BS	2.19	0.16
without BS	3.48	0.008 T

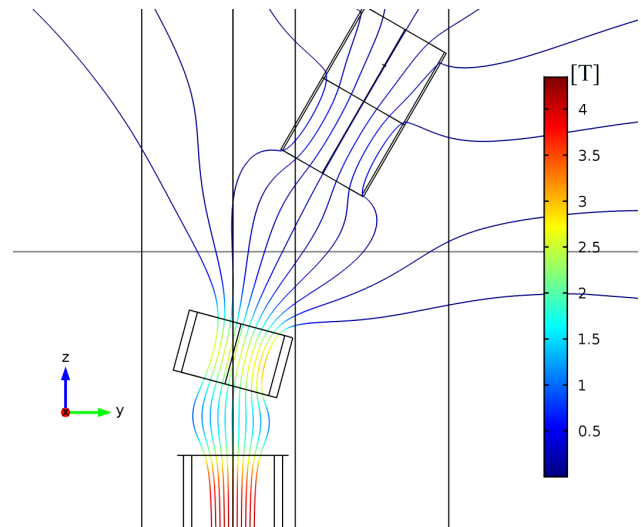

Figure 3: Field lines as estimated in Comsol.

## PRELIMINARY MECHANICAL DESIGN

The MS and the BSs are superconducting, with niobium-titanium wires. They are assembled inside cryostats cooled by liquid helium at 4.5 K available in the LHC tunnel. The GS work at a field level that could be obtained using normal

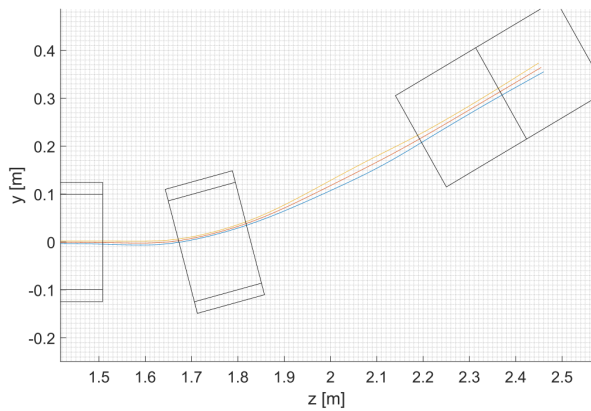

Figure 4: Trajectory estimated with the optimal parameters, zoom on the inlet bending.

resistive coils. A resistive solenoid of 0.4 – 0.5 T requires copper winding dissipating 10-15 kW power. With liquid helium available in the tunnel and already used in the other coils, we think that superconducting solenoids are the best choice for the GS as well. This also facilitates the compactness of the system.

A 3D view of the whole system is shown in Fig. 5 [9]. The MS dimensions are a trade off between the minimization of magnetic energy stored and the assemblability (that is facilitated when the solenoid is big). The result is an inner diameter of 199 mm. The solenoid is 3 m long and is divided in 3 equal independent parts for efficient quench protection. The cryostats are in stainless steel and have a central bore to house the room temperature vacuum chamber where the LHC beam and the hollow electron beam travel. Support is provided by G10 short tubes.

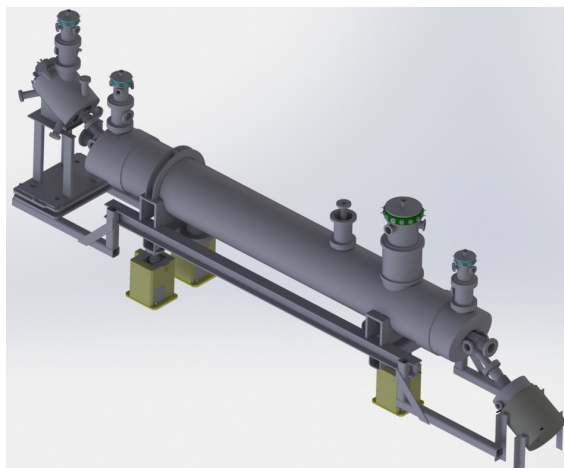

Figure 5: 3D view of the HEL system.

The BSs are hosted in the same cryostat of the MS, Fig. 6. In fact, the force acting between the magnets is above 40 kN. By hosting MS and BSs in the same cold mass, there are no thermal losses through the supports.

In case of continuous mode use of the HEL the maximum power deposited on the collector is 50 kW. The first draft of

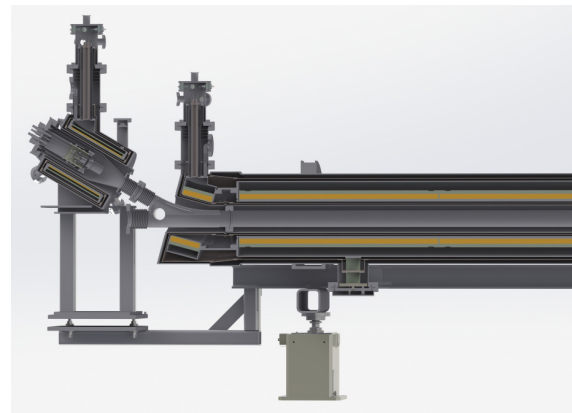

Figure 6: Open view of the HEL system, inlet region.

the collector is a 400 mm × ∅300 mm copper bucket with water cooling on the lateral surfaces. The simulated peak temperature is less than 90 °C with a water flow of 8 ls<sup>-1</sup> (1 ms<sup>-1</sup> speed). A ferrite shield is foreseen around the collector to open the magnetic field lines and therefore the electron trajectories. In absence of such a shield, all the power would be concentrated on a very small surface, with a power density around 160 Wmm<sup>-2</sup> instead of 0.55 Wmm<sup>-2</sup>. Figure 7 show the temperature obtained with a conceptual geometry of the collector, by means of a coupled fluo-thermal analysis.

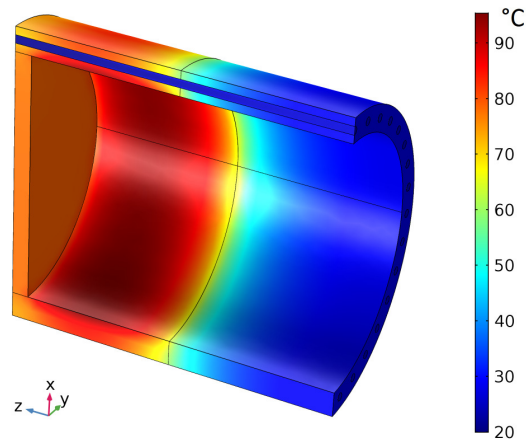

Figure 7: Temperature profile in the collector concept estimated with a coupled fluo-thermal analysis.

## CONCLUSION

A Hollow Electron Lens has been proposed to facilitate halo control and collimation for HL-LHC. The conceptual mechanical configuration has been presented. A simplified script that estimates the trajectories position has been prepared to quickly iterate between possible concepts. The system is now considered feasible through a compact concept made of 5 superconducting solenoids, in which the inlet and outlet field lines of the main 3 m solenoid are bended by 2 strong solenoids. Future activities include research on high-performance cathodes and the detailed design of all the subsystems.

**REFERENCES**

- [1] V. D. Shiltsev “On possible use of electron lenses in LHC” CARE-HHH-APD Workshop on Finalizing the Roadmap for the Upgrade of the CERN and GSI Accelerator Complex, 2007.
- [2] V. D. Shiltsev “Electron Lenses for compensation of beam-beam effects: Tevatron, RHIC, LHC” 3rd CARE-HHH-APD Workshop: Towards a Roadmap for the Upgrade of the LHC and GSI Accelerator Complex, 2008.
- [3] G. Stancari et al., “Collimation with Hollow Electron Beams,” Phys. Rev. Lett. 107, 084802, 2011.
- [4] V. D. Shiltsev “Electron lenses for super-colliders” Springer, 2016.
- [5] G. Stancari et al. “Conceptual design of hollow electron lenses for beam halo control in the Large Hadron Collider”, CERN-ACC-2014-0248, Geneva, 2014.
- [6] M. Reiser. “Theory and Design of Charged Particle Beams”, Wiley-VCH Verlag GmbH (2007) <http://dx.doi.org/10.1002/9783527617623>
- [7] J. P. Boris “Relativistic plasma simulation-optimization of a hybrid code” Proceeding of Fourth Conference on Numerical Simulations of Plasmas, 1970.
- [8] H. Qin et al. “Why is Boris algorithm so good? ” Physics of Plasmas 20, 2013.
- [9] D. Perini and C. Zanoni “Preliminary Design Study of the Hollow Electron Lens for LHC”, CERN-ACC-NOTE-2017-0004, Geneva, 2017. <http://cds.cern.ch/record/2242211>