

EXPERIMENT AND INSTALLATION OF HIGH RESOLUTION STEERING MAGNET POWER SUPPLY FOR SPring-8

Hideki Takebe, Koji Tsumaki, Chao Zhang, Sakuo Matsui and Hitoshi Tanaka
SPring-8, JAPAN

ABSTRACT

High-resolution steering magnets are required for the slow feedback system of the beam orbit correction at SPring-8. Forty-eight sets of high-resolution power supply system were developed and installed to the storage ring in Summer 2004. Four ways of modification to a 20 bit or 23 bit resolution power supply are investigated and two systems are developed. Double DACs' high definition power supply system is installed to SPring-8 and works good for the Top-up operation.

INTRODUCTION

Storage ring normal steering magnet (NST, 576 sets) uses an iron core and the current of the power supply (StP, Fig.1-a) is set within $\pm 5A$ using an RIO system type-A (Fig.1-b). This type-A RIO card (RIO-A) consists of a 16bit DAC, 16bit ADC, 8bit DI and 8bit DO, and connected to a master RIO module in the VME chassis through an optical fiber [1]. Forty-eight sets of high resolution steering magnet (HRST), which is an air core type, were installed to the storage ring in 2001. The magnetic field of HRST is 1/100 of the NST and the same type power supply is used. Twenty-four sets of HRST magnets in horizontal direction, and twenty-four for vertical one, are used as a high-accuracy orbit correction for the slow drift of the closed orbit distortion (COD). The HRST current had to be reset and corrected with the NST in 1 or 2 times a day because the dynamic range and the number of the HRSTs were insufficient. The Top-up operation started in 2004, a continuous operation for a few weeks became to be done, and more 48 HRSTs have been needed for the slow COD correction.



Fig.1-a. Steering magnet power supplies.



Fig.1-b. RIO card type-A.

Therefore, the resolution of the power supply was scheduled to be smaller, using the existing steering magnets (NST). The following four methods for a power supply remodeling are planned and two methods were examined. Practical use and installation to the storage ring had achieved (2004.8) by one method. A resolution, a hysteresis effect and an accuracy of the magnetic field to the current of NST are verified before this test and reported in Acc-memo [2]. Figures excerpted from this Acc-memo are shown below. StP current and hall output voltage for magnetic field are shown. Relation between current and magnetic field, when changing by current step of 0.157mA corresponding to the LSB of 16bit DAC, is shown in Fig.2 (left). Right side of the Fig.2 shows those with an attenuation of the DAC output to be 1/11, and then the step is 0.014mA.

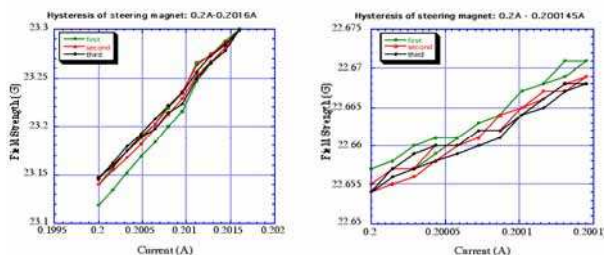

Fig.2. Current and magnetic field relations of the steering magnet.

Table 1 shows types and the number of the steering magnets for the COD correction (X and Y directions). The power supply (StP) of NST decided to be modified to higher resolution because the number of NST will be decreased when the HRSTs of an air core are placed. A new type high definition steering magnet power supply (HD-StP) was designed from the viewpoint of accuracy, reproducibility (of a magnetic field vs. current of NST with the iron core), dynamic range, and stability. Depending on the recent operation of the storage ring, the dynamic range was assumed that three times of the HRST's one, then the DAC an output level was decided to 1/32 of the NST (Table 2). Thus, it came to manage a high-resolution correction for the storage ring operation time from September 2004, for a long time Top-up operation, using 96 power supplies of the HRST and HD-StP totally.

Table 1: Type of the steering magnets (X and Y directions, total sets) for the COD correction.

Normal correction	Iron core normal steering magnet (St) 576 sets
High resolution correction	Air core steering magnet (HRST) 48 sets
High resolution correction (New)	Iron core normal steering magnet 48 of 576 sets (St with HD-StP)

Table 2: Parameter of Steering Magnet and power supply (StP).

Magnet Type	PS name	Max.Field (v), Max. Kick Angle (h)	Max.Current, Resolution	Min.Field(v), Min. Kick Angle
NST Iron Core	StP	26680 G cm, 1mRad	±5A, 16bit, (0.15mA)	0.8G cm, 30 nRad
HRST Air Core	StP	300 G cm, 10μRad	±5A, 16bit, (0.15mA)	9mG cm, 0.3 nRad
NST Iron Core	HD-StP (New)	26680 G cm, 1mRad	±5A, 21bit, (4.7mA)	25mG cm, 0.95 nRad

(The maximum horizontal magnetic field of a vertical Steering magnet is 13340 G cm.)

INVESTIGATION FOR A HIGH-DEFINITION POWER SUPPLY

Four plans of a high-resolution modification of the StP are shown as follows.

- 1) Plan-A: Four bit of DAC is installed to the NST power supply and added to the normal 16 bit DAC of the RIO (type-A). The four bit data is controlled by digital outputs of the same RIO.
- 2) Plan-B: A 16 bit DAC of an extra RIO (type-A) is added into the StP unit. The analog output signal of this extra DAC is reduced by 1/100 or 1/32 and is superimposed to the NST current signal as a fine control signal. When this reducing factor takes 1/32, it evaluates a 21-bit DAC.
- 3) Plan-C: When the chassis of the StP unit cannot be assembled by the RIO plan-B, three or six RIO-DACs are mounted to the 36 StPs cubicle.
- 4) Plan-D: Development of an optical IO board/card with 20 bit DAC. An IO board with Di, Do, Ai, and Ao is newly established.

Detail Investigation is described as follows,

Plan-A: 16+4 bit DAC for Steering PS

A current set of the NST power supply is controlled by the DAC of the RIO-A, and on/off/reset commands are controlled by the digital output of this RIO. For evaluates the NST fine current set, four bit of DAC can be installed to the NST power supply and added to the normal 16 bit DAC of the RIO (type-A). This four bit data is signaled by digital outputs of this RIO's, which are not used before. (Fig.3)

Upper software is the same, if the RIO 20bit DAC control program (in the VME; EM) is established.

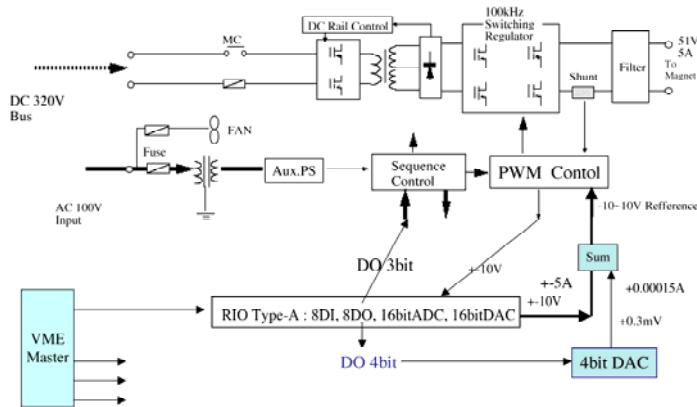

Fig.3. Plan-A.

Remodeling subordinate level software (EM) is important because a simultaneous setting of two DACs must be needed. We should check some problems in linearity, accuracy, and strobe timing. It might be necessary for selecting good RIO card, which has a better DAC linearity.

Plan- B: 16+16 bit Double DACs for Steering Magnet Power Supply

A DAC of an extra RIO (type-A) is added into the NST power supply unit. The analog output signal of this extra DAC is reduced by 1/100 or 1/32 and is superimposed to the NST current signal as a fine current signal. When it takes 1/32, it evaluates a 21-bit DAC. (Fig.4)

Extra RIO (sub RIO) is adopted into a normal StP attenuated by 1/32 (+0.156A~-0.156A) and added to the normal DAC output (main; +5A~-5A). The sub RIO is controlled in a different address from a main RIO address. (It is assumed only the operation of DAC and ADC. Status, on, off, and reset signals are not used.) If 48 set of stocked RIO-A are used, the cost can be minimum in this plan-B. Remodeling Software is easy, if the sub RIO used as a HPST.

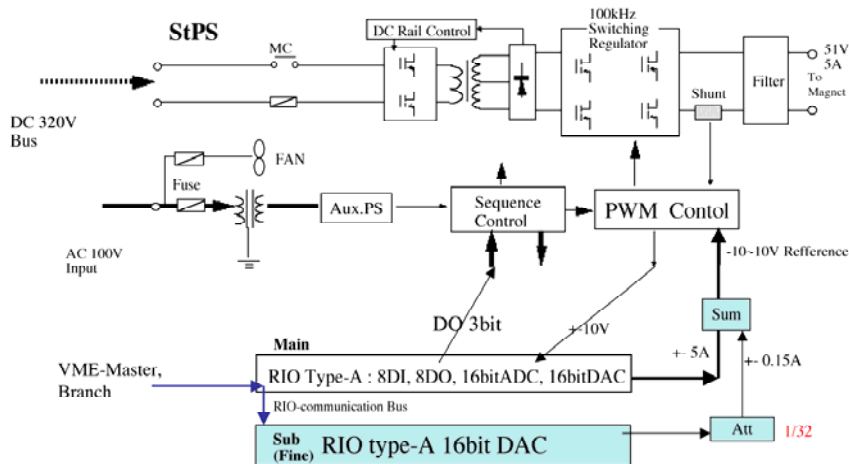

Fig.4. Plan-B.

Plan-C: Extra DACs are installed to one chassis for the required Steering PSs

Three or twelve DACs (RIO-A or VME 3ch or 12ch DAC module) for the 36 or 144 StPSs are assembled in one chassis in each PS-room A, B, C and D, respectively. Analog DC +10~ -10V signal cables are connected to the required each ST-PS and attenuated (Fig.5) for a fine control. In case of using a VME 12ch DAC module, new software must be created. (This is a disadvantage compare to the optical fiber RIO system about isolation electrically.)

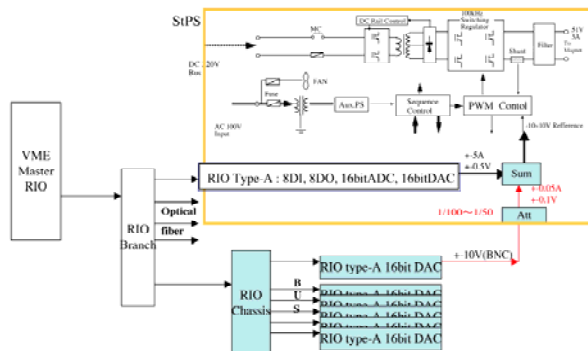

Fig.5. Plan-C.

Plan-D: New 20 bit DAC for Steering Magnet

New development for a 20bit DAC I/O card with an optical fiber link, Di, Do, Ai, Ao is also considered.

The largest cost for the RIO-A sized new card development is needed. Upper software is the same, if the 20bit DAC control program (in the VME; EM) is established.

PROTOTYPE TEST AND EXAMINATION

We made prototype HD-StPs of the two plans (A and B), and examined.

Plan-A: Linearity test for 16bit+4bit DAC.

Figure 6 shows current vales of a prototype HD-StP (Plan-A) setting. The pink squares in this figure (upper) show the least significant bit (LSB) change of the normal 16 bit DAC (RIO-A). The blue dots show current values of the 4bit DAC change before a scaling resistance adjustment. When the scale of this 4bit DAC is adjusted (lower, red triangles), it seems to obtain the linearity of considerable 19bit, therefore the error margin will be about 2ppm.

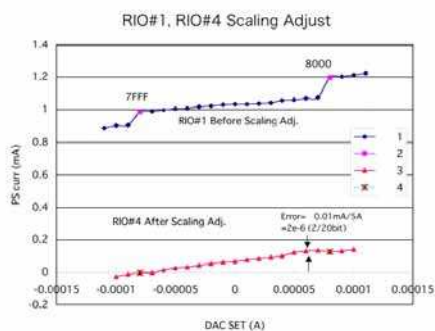

Fig.6. Current of a prototype HD-StP plan-A.

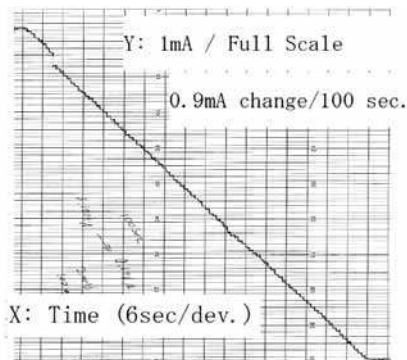

Fig.7. Current chart of HD-StP plan-A.

Figure 7 shows a real time current change plot from 0.1001A to 0.101A for 100 second, using a ramping program from the VME. It shows no error found at the current set strobe timing (between 16bit DAC and 4bit DAC), but shows some linearity errors.

In the plan-A, a continuous securing of a minimum bit of 16 bit DAC for high-resolution evaluated DAC is necessary. Therefore, a linearity error margin of a minimum bit of existing four RIO cards was measured.

Four RIO-A cards were checked in changing five digits between 7FFF and 8004 (hex) as seen in Fig.8. The most significant bit (MSB) and the LSB are exchanged at 7FFF-8004 (hex). Result of

examining these four RIO's DAC setting error margin, there were about 1/4 or 1/3 of LSB value.

After these measurements, more accurate measurement has been done using a high-precision DCCT and offset recorder. The worst linearity error has been found not only in the MSB or LSB but also in the mid-range significant bit for the investigated six DACs.

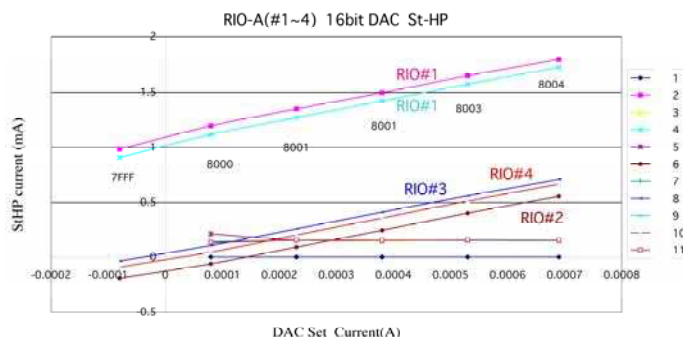

Fig. 8. Four RIO cards were checked for DAC linearity.

Plan-B; Assembling RIO Card to the Power Supply and Examination

The extra RIO (sub) for the fine control DAC can be assembled in just next to the main RIO, because a good space is opened in the steering power supply unit as seen as fig.9 (lower). Data communication of the sub RIO is achieved by an RIO data BUS (wire connection in backward), so they communicated with VME RIO master with only one optical fiber. (As a result, plan-C became unnecessary.) The examination of the plan-B was done after the production delivery in April 2004, and drove for a long time test.

A current control program was made and examined. Figure 10 shows a real time current chart. The normal DAC (RIO-main) changed by a ramping program from 0A to 0.016A for 30 second. It is found step-changes at left side in this Fig.10, and that of the fine DAC (RIO-sub) is found in right side.



Fig.9. Rear view of HD-StP plan-B (lower).

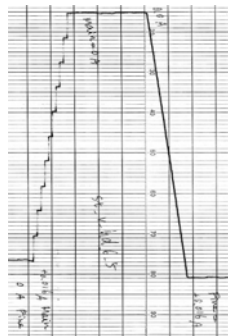

Fig.10. Current: main (left) and fine (right) DACs.

Stability Examination (for Plan-B)

Stability check was done in a prototype HD-ST (on April 24, 2004). The RIO main was set for 1A with a resistance load as seen in Fig.11, measured by using a standard shunt resistance and DVM. The sub RIO's DAC attenuation factor was set to 1/100. Current of the sub RIO was set to $-0.01A(x0.01) = -0.1mA$, and $-0.01A(x0.01) = -0.1mA$ at the first 2 peaks. Stability was checked for 38 hours, and found in 15ppm/38H against 5A full range (20ppm/Div against 1A). Also the stability was examined in using the 48 sets of HD-StPs and seen in Fig.12, which measured by high-precision DCCT (HITEC Co., TOPACC) and high-precision offset recorder system [3] in the power supply room. The stability was found within 8ppm for three days. The StP power supply room temperature is controlled in 23 ~ 27 degree C.

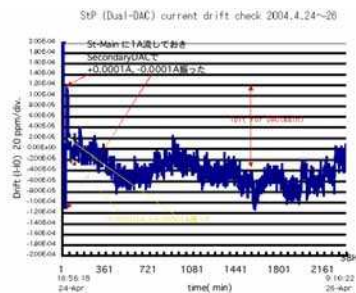
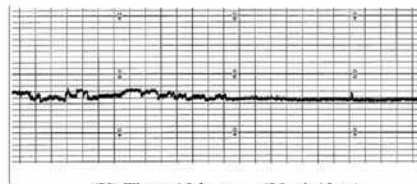

Fig.11. Stability of the prototype HD-StP.

(Y) 6digit=0.15mA, Stability= 6ppm/ 12H, 8ppm/ 3 days



(X) Time: 12 hours (30min/dev.)

Fig.12. Stability of HD-StP

CONCLUSION

As for the examination result, operation and the stability level were gotten as expecting by plan-B. To put out the good linearity for 20bit in plan-A, a fine investigation is necessary to select the RIO-A with good DAC linearity. Comparing to this, the slow feedback program can use this new HD-StPs as same as the HRST, if the same operating method as HRST is taken (though it is not necessary to select the good DAC). Making a balance of the high-resolution evaluation and the dynamic range, it can be decided by the resistance division factor in plan-B. For a practical installation to the storage ring, it has set to 1/32, then the resolution became to 0.94ppm against to the StP maximum current (5A), and the dynamic range became to three times of the HRST. Software can use the existing one, and we use it as the power supply of HRST.

The production cost of this plan-B was lower than the plan-A, when stocked RIOs were used. As the RIO can be mounted into the power supply unit easily with the plan-B, the plan-C with RIOs was assumed to be unnecessary. Furthermore, the cost of new type RIO development was too large then the plan-D was not taken.

Forty-eight sets of the StP were modified to the HD-StP as the plan-B, and installed in August 2004. The first practical operation has done in SPring-8 storage ring from September 2004 to August 2005. The resolution, stability, accuracy and the dynamic range of this system are good enough [3]. Fig13 shows a beam current and orbit change only with HRST in June 2003 (left), and shows that after installing the HD-StP into the storage ring (with HPST also) for a Top-up operation in September 2004 (right).

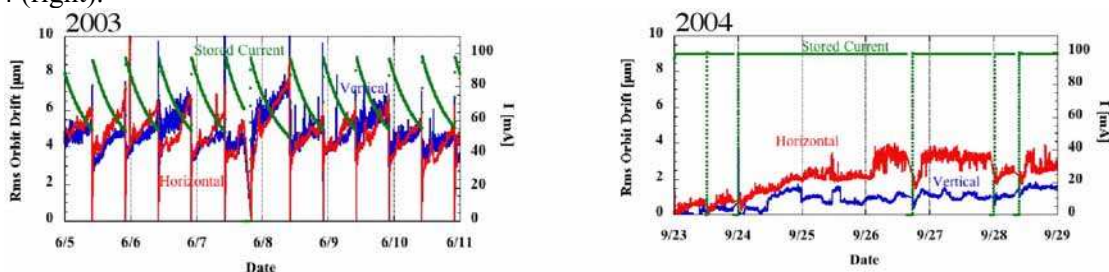

Fig.13. Beam current and orbit change with only HRST (2003) and Top-up operation with HRST and HD-StP (2004).

REFERENCES

- [1] "Magnet Power Supply Controls of the SPring-8 Storage Ring." H.Takebe, T.Fukui, K.Kumagai, T.Masuda, J.Ohnishi, A.Taketani, R.Tanaka, T.Wada, W. Xu and A. Yamashita, ICALEPCS 95, KEK, Tsukuba, JAPAN.
- [2] "Measurement of hysteresis of steering magnet for highly accurate orbit correction." K.Tsumaki, H.Takebe, and C.Zhang, Acc-memo, August 4. 2003 (written in Japanese). <http://acc-web.spring8.or.jp/~takebe/mag/STHD/STM-histerysis.htm>.
- [3] "Present Status of Orbit Stabilization at SPring-8." H.Tanaka, The 3rd International Workshop on Beam Orbit Stabilization 2004, December 6-10, 2004, Hotel Kirchbul, Grindelwald, SWITZERLAND. <http://iwbs2004.web.psi.ch/documents/program/Tanaka.Hitoshi/1.pdf>.