

CUSTOMIZATION AND TUNING OF THE CONTROL SYSTEM FOR THE TIME OF FLIGHT DETECTOR OF THE ALICE EXPERIMENT

O. Pinazza¹, P. Antonioli¹, F. Cindolo¹, A. Polini¹, E. Scapparone¹, S. Sellitto²
¹INFN, Bologna, Italy, ²INFN, Salerno, Italy

ABSTRACT

The control system of the ALICE TOF detector is based on PVSS, a SCADA system that has been selected by CERN as the common platform for the LHC experiments.

Although PVSS has been extended to offer standard tools to the different detectors, the TOF controls required specific developments to include the communication with custom electronics and to fulfil the requirements by the physicists on data archiving and retrieving, and for quick graphical and statistical analysis.

This paper will present the TOF Detector Control System, describing monitoring and control functions for the various subsystems: high and low voltages, gas and cooling, and readout electronics. While high and low voltages are monitored via OPC, electronics monitoring and controls use the DIM client-server system, to allow a common integrated interface implemented in PVSS.

TOF has organized several tests to check the performance and robustness of fully equipped and simulated systems where a large amount of data has to be monitored in a moderately hostile environment; the results of these tests are presented.

INTRODUCTION

ALICE (A Large Ion Collider Experiment) is a heavy-ion detector under construction for the Large Hadron Collider (LHC) at CERN. The Time Of Flight (TOF) is one of ALICE's sub-detectors devoted to charged particle identification.

TOF is a wide area array (about 150 m²) of gaseous detectors, based on the Multigap Resistive Plate Chamber (MRPC) technology [1], [2]. It's composed of 1638 MRPC strips with 157.248 readout pads 9 cm² each, covering a cylindrical grid.

The detector running is managed through several subsystems: data acquisition, trigger and service control systems.

THE CONTROL SYSTEM

The development of a control system for all the LHC detectors has been coordinated by CERN, and PVSS, an integrated commercial system, has been selected as software platform [3], [4]. A working group inside CERN (JCOP) has then extended PVSS to offer a common framework to all experiments including several standard devices common in high energy physics; the TOF controls will be based on the CERN-JCOP recommendations.

At present, the High and Low Voltage systems have been implemented. For both systems, remote controls rely on OPC over TCP/IP, a client-server protocol based on Microsoft software architecture, which has grown today into an industrial standard. Several devices as the commercial power supplies used by TOF, are now equipped with an OPC software interface that broadcasts items and listens to commands from the PVSS control stations (acting as OPC client), through an OPC server.

Less standard devices, such as the Front-End Electronics, are controlled through a remote computer connected with a fiber optic cable. The computer hosts a DIM server and talks to DIM clients, in a similar to OPC, but more general and customizable, way. DIM is a client-server communication system made by CERN and is used by TOF to broadcast values and status items to the control system and to send commands to the device.

The High Voltage system

TOF is made of 18 azimuthal sectors, and each sector contains 5 modules. The 90 modules are equipped with MRPC strips, located in a gas volume and working with a high voltage of about 12.5 kV. Each module is fed by two high voltage channels (positive and negative). Standard high voltage

boards have been selected and tested to perform this function; they are produced by CAEN S.p.A. and are called A1534. The 32 boards are hosted in two CAEN SY1527 power supplies located in one of the control rooms, and are connected to the modules with 100 m long high voltage cables (Figure 1).

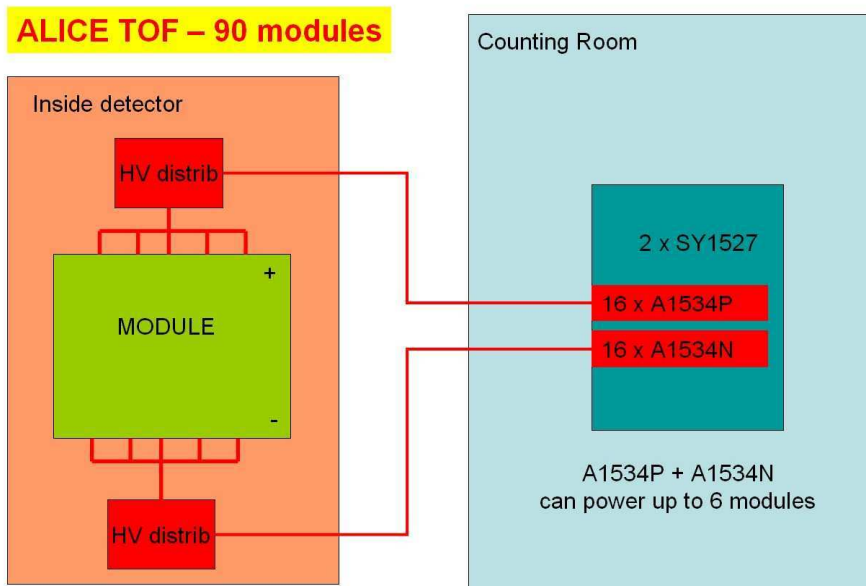

Figure 1. TOF HV control scheme

The HV controls have been implemented using the Framework tools and datapoints made available by CERN, while the user panels had to be redesigned to include some graphical representations requested by the physicists (Figure 2).

Furthermore, an alternative custom data archive has been set up, to simplify the access to the data for a quick analysis with different tools.

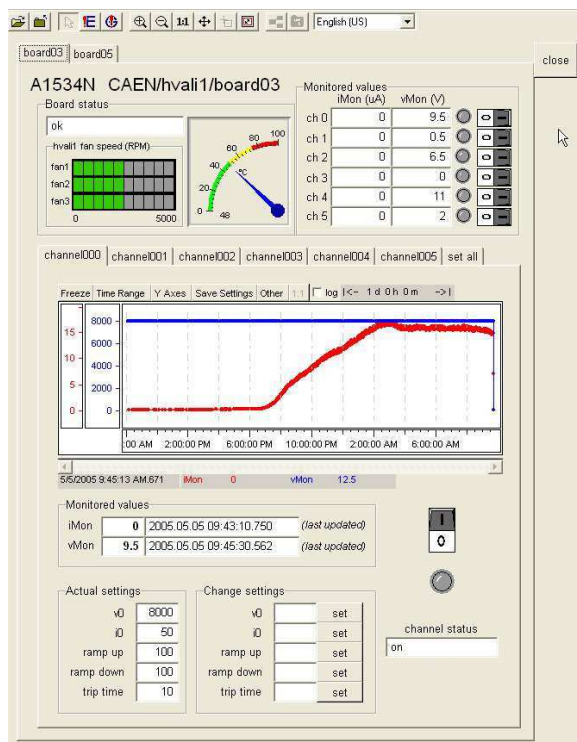

Figure 2. Custom control panel for the HV system

The Low Voltage control system

Each TOF sector is powered and controlled through four custom Easy-like crates, called *Alice-box* (Figure 3), and located near the detector, inside the solenoid. Therefore, the system is planned to be resistant to a slightly harsh environment.

The boxes are characterized by a water cooled case, and will host the readout electronics. A General COntroller (GECO) onboard the boxes is connected to a branch controller board (A1676A) hosted in a CAEN SY1527 power supply, located in the experimental hall, where a residual magnetic field of about 60 gauss has been measured.

Four SY1527 distributed around the detector host two branch controllers A1676A each, connected to 18 crates (one TOF quadrant) via EASY bus (Figure 4). The whole system is powered by 12 customized 48 V power supplies called Maciste, designed to work in a moderately hostile area and controlled as low voltage channels through a GECO (General Controller) device. Four additional commercial Maciste will supply the service power for control electronics.

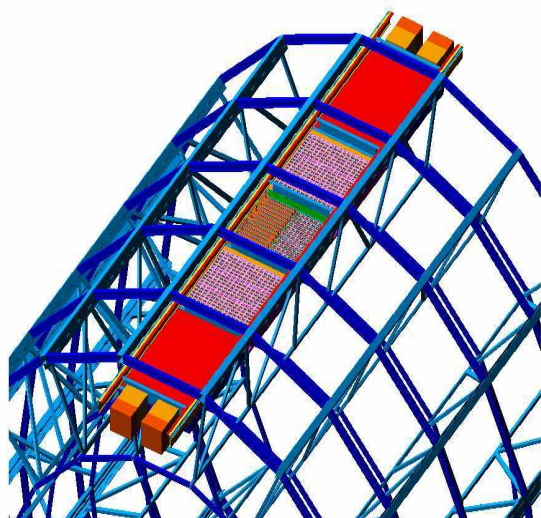

Figure 3. A TOF sector and the four Alice-boxes at the ends.

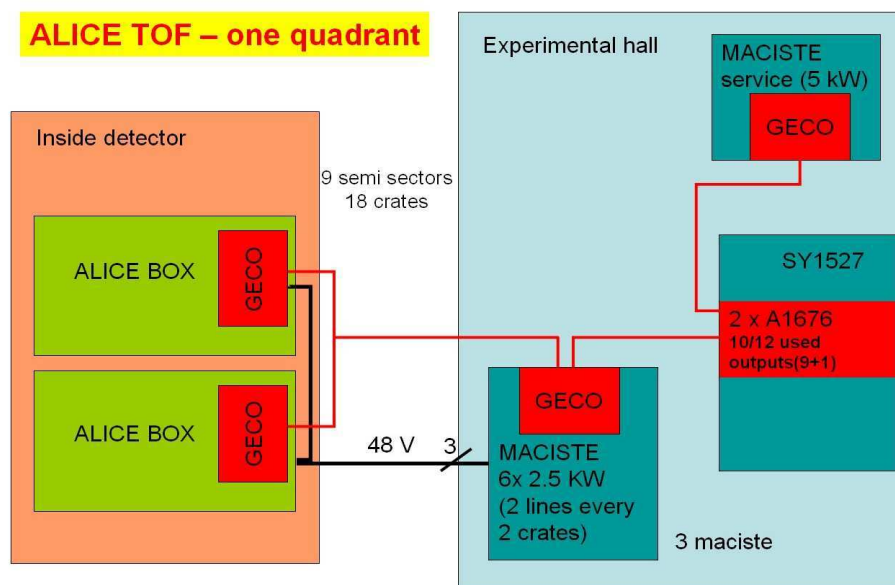

Figure 4. LV scheme for a TOF quadrant.

The Alice-box crates (Figure 5) are derived from the Easy boxes; they are composed by one digital channel with 3.3 V and 200 A derived from two A3100 modules, and twelve analog channels with lower current derived from the A3009 module. Eleven channels work with 2.7 V and 7 A to feed the

front-end electronics inside the TOF modules, while the channel with 5 V and 2 A will serve some electronic components in the Alice-box.

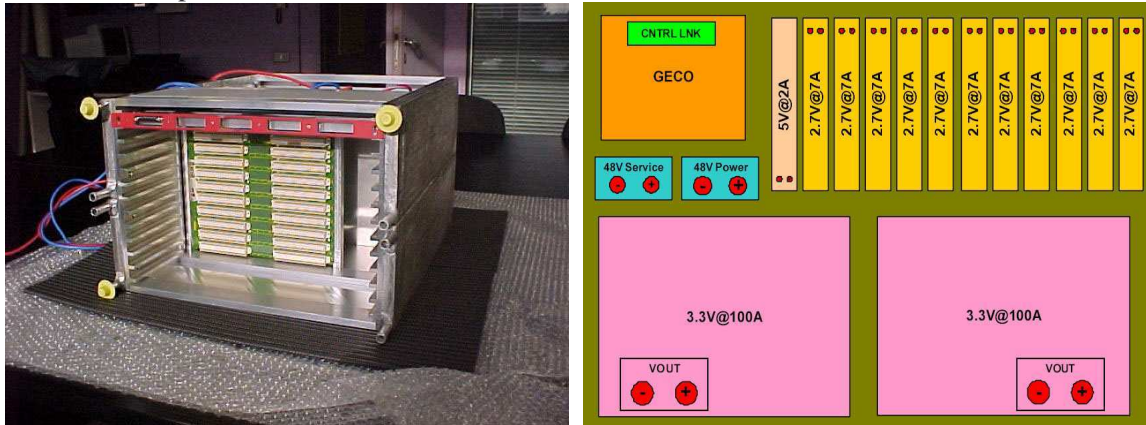

Figure 5. The Alice-box case and its logical scheme

Other subsystems

The next subsystem to be integrated in the TOF DCS will be the Front-End Electronics (FEE). From the DCS point of view, FEE controls are limited to status monitoring and activation of procedures, like calibration, but strong interactions with the DAQ system are foreseen.

Service subsystems like gas, cooling and ventilation, electricity and electronic racks, are being developed by specific working groups organized by the ALICE experiment, and will be integrated in the TOF DCS through the Finite State Machine (FSM) mechanism, described below.

PERFORMANCE AND ROBUSTNESS OF THE CONTROL SYSTEMS

The HV system will work in the safe environment of the counting rooms. It's been the first system to be completed and has been used since 2004 to control and monitor the modules during experimental setup and test beams. At present, it's performing a long term test in a cosmic ray test facility at CERN. During these working periods the system has proved to depend on the number of monitored channels and to use a large amount of memory; however, TOF will use only 180 HV channels, which will easily be controlled using a dedicated modern PC running a devoted OPC server.

The LV system has been designed for working in a slightly hostile environment, therefore the components and the materials used had to be guaranteed for radiation and magnetic fields resistance, and fan cooling has been substituted by water cooling.

While the LV mechanical and thermal performances have been tested in a magnetic field at Prévessin, the tests for controls and communications have been performed in the final position: the experimental hall at Installation Point 2, during the ALICE solenoid and dipole magnetic field mapping.

No loss in communication and power quality was observed, with a magnetic field value of 6750 gauss, oriented like the one foreseen inside the ALICE experiment.

The test was used also to validate the special twisted pair cable 60 m long, that will connect the crate inside the magnet to the branch controller in the experimental hall. Here, the magnetic field has been measured, and found lower than expected: less than 60 gauss in the rack area, and less than 20 gauss inside the racks. During the tests, a fan cooled SY1527 has been used without noticing any problem.

SOME REMARKS ON PVSS AND OPC

Besides the tests in the magnetic field, several tests have been made in order to test the possible loss of performance, simulating increasing loads and using different software and hardware solutions.

OPC communication and network problems

A first version of the controls for the HV system was prepared two years ago, and has therefore followed the transition from PVSS II version 2.12 to 3.0, and the migration from Windows 2000 to

XP. While the previous version presented several upsetting problems with loss of OPC communication, the present version is much more reliable. Furthermore, using XP instead of Windows 2000 provides the benefit of a better process management, since the critical programs (like OPC server) run as “services”.

At present, in the laboratory setup, some problems with TCP/IP communication are still observed because some network apparatus are unable to properly negotiate the velocity with the network boards of power supplies and devices.

Framework tuning

The whole TOF DCS is being implemented using PVSS and Framework, as required by ALICE. The TOF software projects are subjected to periodic software revisions, due to the frequent updates of the Framework tools, that are standardizing the devices controlled by the DCS, including the custom TOF crates and boards.

The Framework datapoints are organized in standard OPC groups, and read all the parameters of the channels and devices, with a heavy network and memory load for the control system. Since some parameters are more critical and vary faster than others, more static, TOF decided to optimize and reorganize the OPC groups and datapoints to have a more reliable and optimized reading, especially during the present test and construction phase.

Data availability

Data archiving in PVSS is implemented through a proprietary RAIMA database, that can not be interfaced by external applications. A different database and user friendly data extraction tools are not available yet.

As a temporary solution, TOF has developed a concurrent archive in a much more standard way, permitting an easy access to data for a quick and easy plot or analysis, as required by the physicists.

Hopefully, a future version of the PVSS software will supply this double load and double disk space waste with a better archiving and retrieving mechanism.

Robustness and security issues

The number of channels being monitored and controlled with PVSS is not very large: the TOF will have 180 HV channels (15 negative and 15 positive boards with 6 channels each) and about 1000 LV channels (72 Alice-box with 14 channels each, 12 Maciste, with 7 channels each, and 4 Maciste with 1 channel each). A normal desktop computer should withstand a similar load; however, the system has been optimized with a rearrangement of OPC groups, the tuning and reduction of LV monitored items and the partitioning over different servers.

Some security issues have become clear while running PVSS projects in the public network of the TOF laboratories; the PVSS processes open and listen on TCP non standard ports that are scanned daily from external hosts, with the risk of loosing the control of the devices.

When the ALICE experiment will work at LHC, a firewalled network will limit outside breaking into the control computers, allowing only authenticated and authorized access from outside to comply with the requirements of the physicists.

THE FINITE STATE MACHINE AND INTEGRATION WITH THE ECS

The Finite State Machine (FSM) is a mechanism designed to manage several devices through simple states (on, off, ready, error, ...) and commands (switch on, switch off, reset, exclude, ...). Subsystems and devices are organized in hierarchical logical layers to enable the control of an elementary partition of the detector.

Due to its mixed HV and LV management, the elementary TOF partition is one sector (shown in Figure 3), composed by 5 modules of the HV logic, or 4 quarters of the LV and FEE logic.

However, this approach is different from the requirements of the Experimental Control System (ECS), which coordinates the FSM design of the different subdetectors. Its scheme is designed to integrate the controls of the ALICE detectors in Activity Domains (DCS, DAQ, Trigger, ...), leaving the complexity of the internal architecture to the detectors [5].

TOF has then designed its FSM plan following two logics (Figure 6): TOF DCS, DAQ and FEE will comply to ECS Activity Domains, while sector partitioning will be used by TOF for the control and management of the devices.

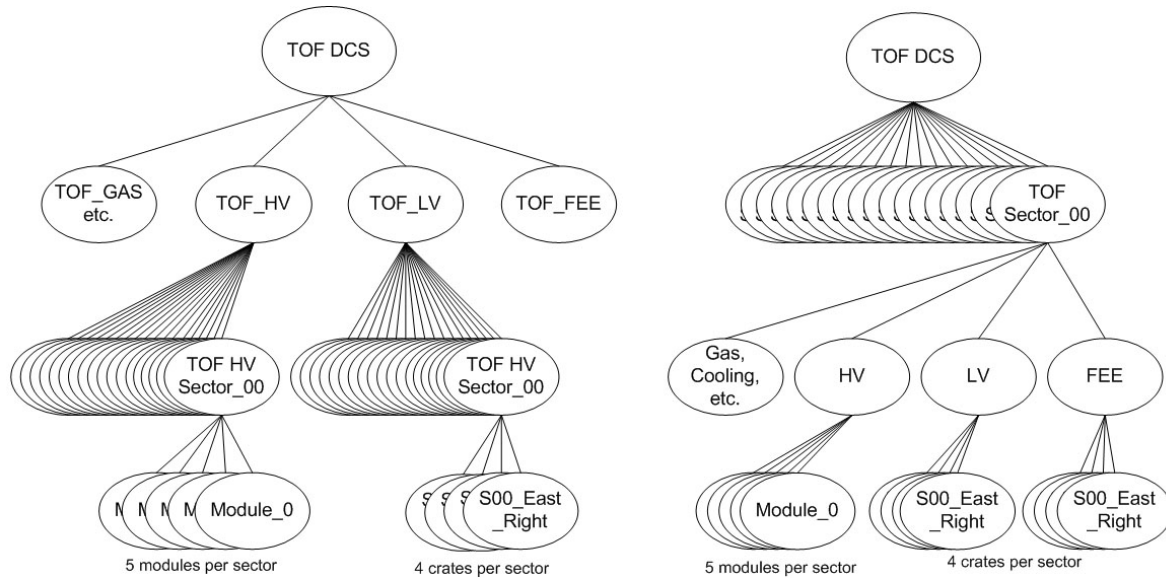

Figure 6. FSM scheme with the DCS Activity Domain (left) and the TOF sector partitioning internal logic (right).

CONCLUSIONS

The TOF Detector Control System is being implemented following the ALICE requirements with some due customizations. The subsystems have been extensively tested during test beams and laboratory setup, where some issues have been pointed out.

Approaching the final configuration, further upgrade and tuning of software and hardware systems are expected to solve most of the highlighted problems.

During the present phase, TOF is facing the effort of integrating several electronic components in a system becoming even more complex, preserving a strict agreement with ALICE standards and conventions.

REFERENCES

- [1] The ALICE Collaboration, "Technical Design Report of the Time Of Flight System (TOF)", CERN/LHCC 2000-12, ALICE TDR 8, 16 February 2000.
- [2] The ALICE Collaboration, "Addendum to the Technical Design Report of the Time Of Flight System (TOF)", CERN/LHCC 2002-016, Addendum to ALICE TDR 8, 24 April 2002.
- [3] A. Daneels, W. Salter, "Selection and evaluation of commercial SCADA systems for the controls of the CERN LHC experiments", Proceeding of ICALEPCS 1999, Trieste (Italy), 4-8 October 1999.
- [4] P.C. Burkimsher, "JCOP experience with a commercial SCADA products, PVSS", Proceeding of ICALEPCS 2003, Gyeongju (Korea), 13-17 October 2003.
- [5] The ALICE Collaboration, "ALICE Technical Design Report of the Trigger, Data Acquisition, High-Level Trigger and Control System", CERN/LHCC 2003-062, ALICE TDR 010, 7 January 2004.